

## PNEUMATIC ACTUATORS

### Pneumatic actuators

#### Aluminium double acting "DA" pneumatic actuator

[features](#)

[features & benefits](#)

[output torque](#)

[codes, dimensions and materials](#)



### Features

#### TECHNICAL FEATURES

Torque from 8 Nm to 3840 Nm.

Mounting flange according to DIN/ISO 5211 DIN 3337

F03 - F04 - F05 - F07 - F10 - F12 - F14 - F16.

NAMUR connection for accessories.

Rotation angle 90°

Torque: directly proportional to the air supply (see table).

The code numbers after the DA letters, always correspond to the breakaway torque in Nm by 5,6 bar air supply.

#### Technical features

Torque from 8 Nm to 8000 Nm.

Mounting flange according to EN ISO 5211

F03 - F04 - F05 - F07 - F10 - F12 - F14 - F16 - F25.

In accordance with EN 15714-3

Rotation angle 90°

Torque: directly proportional to the air supply (see table).

The code numbers after the DA letters, always correspond to the breakaway torque in Nm by 5,6 bar air supply.

ATEX version in conformity with directive 2014/34/EU. Please add YX at the end of the code for ATEX version.

#### WORKING CONDITION

Temperature: from 0°C to +80°C; from -20°C to +80°C with dry air only. (+150°C in special execution)

Air supply: 5,6 bar; maximum 8,4 bar.

Operating media: compressed filtered air, not necessarily lubricated.

In case of lubricated air, either non detergent oil or NBR compatible oil, must be used.

## Features & benefits

"The image may not be representative of the product".

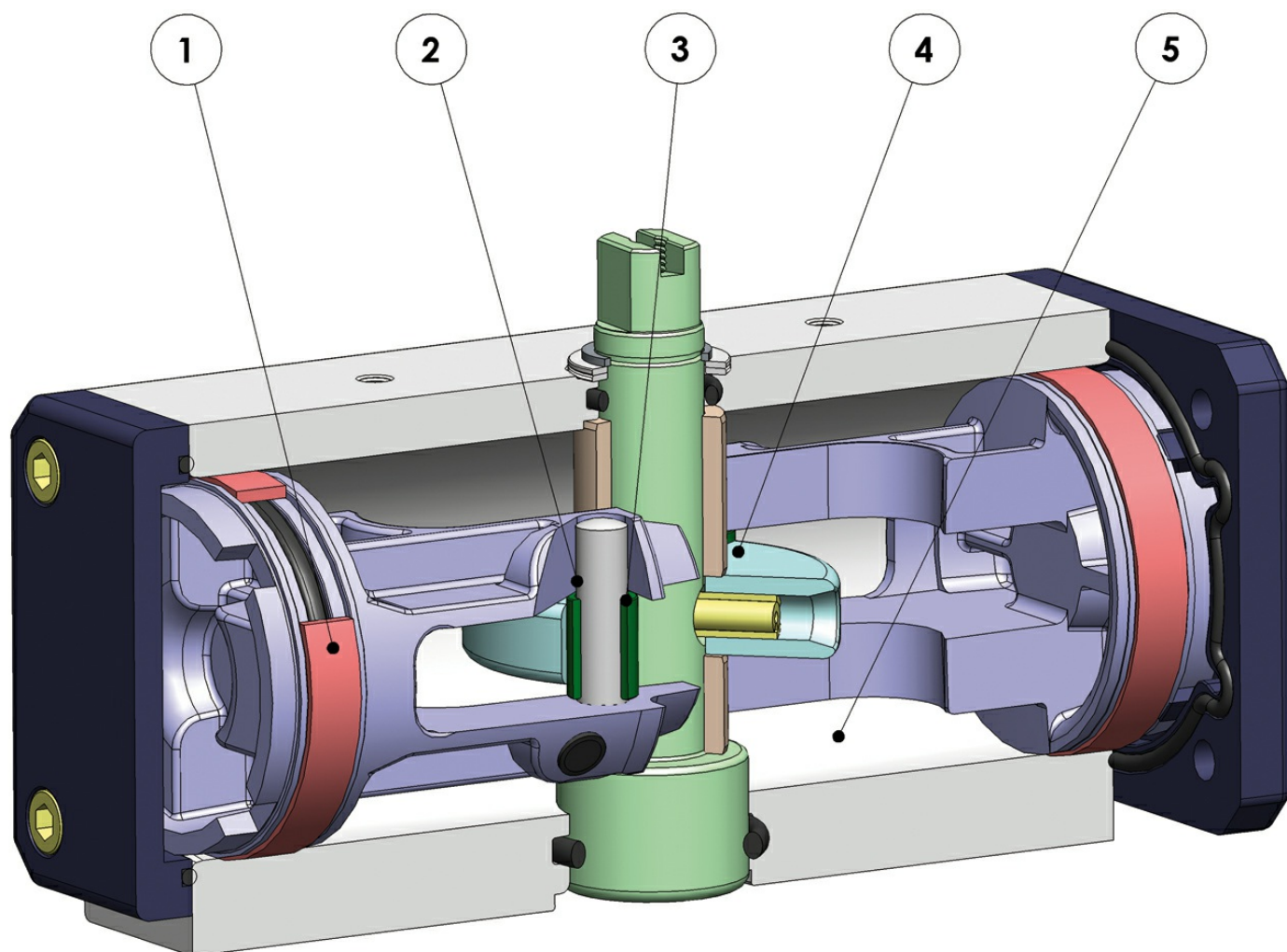

FEATURES AND BENEFITS		
1	Energized and self-lubricated strips	<p>Less friction between piston and cylinder</p> <p>It prevents the bonding of the seal to the cylinder even after long periods of inactivity</p>
2	Slots, bushes and pins made by steel with hardness higher than 50 HRC	Higher resistance to the forces inside the actuator
3	Rolling friction between piston and slot	Less friction
4	Scotch yoke with rolling friction (transforming rotary motion into linear motion using piston and shaft without teeth/gears)	Reduced friction between piston and shaft with consequently less wear on the relevant parts
		Empowered Break Away Torque (BTO & BTC)
		Smaller volume/size than rack and pinion actuators (with the same torque) therefore less space required for installation
		Less weight than the rack and pinion (-30% kg / Nm), with consequent savings on the construction sizing of the plant/equipment

		Lower air consumption compared to the rack and pinion (-40% air cm <sup>3</sup> /Nm for Double Acting and -20% air cm <sup>3</sup> /Nm for Spring Return) therefore less load on the compressor or the possibility of using a smaller compressor's size.
5	Rolled cylinder	Less wear of the energized ties thanks to the low roughness of the surface (0.15 micron Ra)
	100% in- house manufacturing process technology	Maximum control and accuracy in all the stages of the manufacturing process
	ATEX Certificate	Installation is allowed in a potential explosive environment
	SIL 3 Certified	Guarantee of the high level of functional safety.

# Output torque

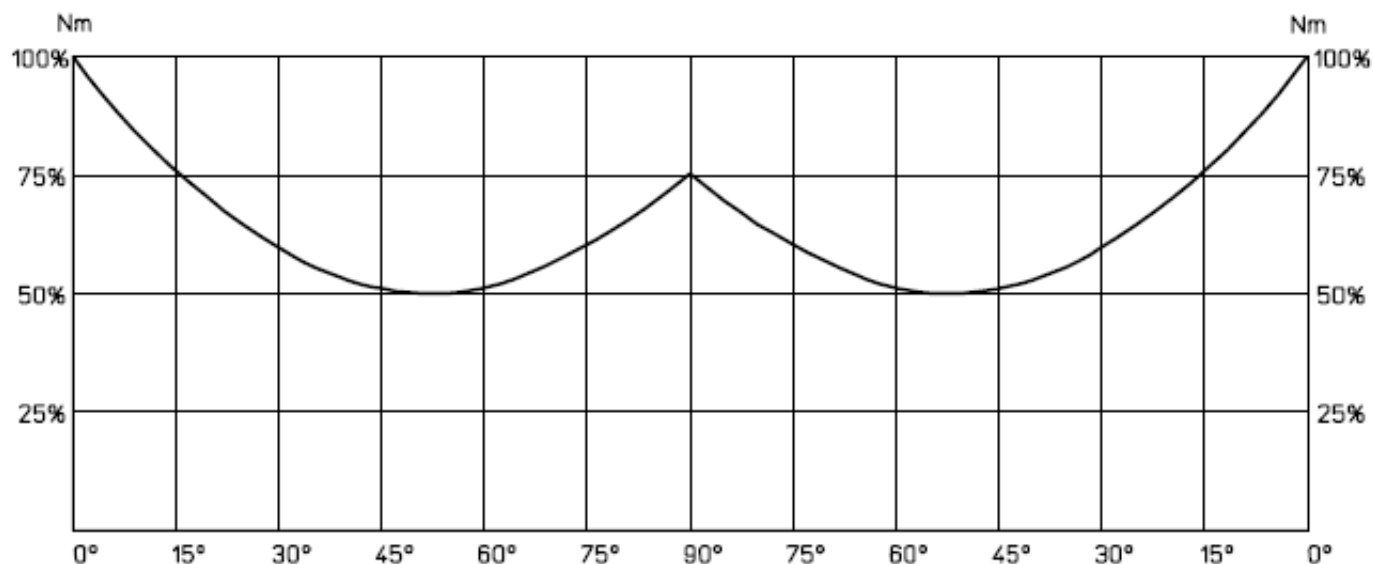

OUTPUT TORQUE TABLE (Nm) $\alpha^\circ =$ rotation angle								
SIZE	$\alpha^\circ$	3 bar	4 bar	5 bar	5,6 bar	6 bar	7 bar	8 bar
DA 8	0°	4,3	5,7	7,1	8,0	8,6	10,0	11,4
	45°	2,1	2,8	3,6	4,0	4,3	5,0	5,7
	90°	4,3	5,7	7,1	8,0	8,6	10,0	11,4
DA 15	0°	8,0	10,7	13,4	15,0	16,1	18,8	21,4
	50°	4,0	5,4	6,7	7,5	8,0	9,4	10,7
	90°	6,0	8,1	10,1	11,3	12,1	14,1	16,1
DA 30	0°	16,1	21,4	26,8	30,0	32,1	37,5	42,9
	50°	8,0	10,7	13,4	15,0	16,1	18,8	21,4
	90°	12,0	16,1	20,1	22,5	24,1	28,1	32,1
DA 45	0°	24,0	32,1	40,2	45,0	48,3	56,4	64,2
	50°	12,0	16,2	20,1	22,5	24,0	28,2	32,1
	90°	18,0	24,3	30,3	34,0	36,3	42,3	48,3
DA 60	0°	32,1	42,9	53,6	60,0	64,3	75,0	85,7
	50°	16,1	21,4	26,8	30,0	32,1	37,5	42,9
	90°	24,1	32,1	40,2	45,0	48,2	56,3	64,3
DA 90	0°	48,0	64,2	80,4	90,0	96,6	112,8	128,4
	50°	24,0	32,4	40,2	45,0	48,0	56,4	64,2
	90°	36,0	48,6	60,6	68,0	72,6	84,6	96,6
DA 120	0°	64,3	85,7	107,1	120,0	128,6	150,0	171,4
	50°	32,1	42,9	53,6	60,0	64,3	75,0	85,7
	90°	48,2	64,3	80,4	90,0	96,4	112,5	128,6
DA 180	0°	96,0	128,4	160,8	180,0	193,2	225,6	264,8
	50°	48,0	64,8	80,4	90,0	96,0	112,8	128,4

	90°	72,0	97,2	121,2	135,0	145,2	169,2	193,2
DA 240	0°	128,6	171,4	214,3	240,0	257,1	300,0	342,9
	50°	64,3	85,7	107,1	120,0	128,6	150,0	171,4
	90°	96,4	128,6	160,7	180,0	192,9	225,0	257,1
DA 360	0°	192,0	256,8	321,6	360,0	386,4	451,2	513,6
	50°	96,0	129,6	160,8	180,0	192,0	225,6	264,8
	90°	144,0	194,4	242,4	270,0	290,4	338,4	386,4
DA 480	0°	257,1	342,9	428,6	480,0	514,3	600,0	685,7
	50°	128,6	171,4	214,3	240,0	257,1	300,0	342,9
	90°	192,9	257,1	321,4	360,0	385,7	450,0	514,3
DA 720	0°	384,0	513,6	643,2	720,0	772,8	902,4	1027,2
	50°	192,0	259,2	321,6	360,0	384,0	451,2	529,6
	90°	288,0	388,8	484,8	540,0	580,8	676,8	772,8
DA 960	0°	514,3	685,7	857,1	960,0	1028,6	1200,0	1371,4
	50°	257,1	342,9	428,6	480,0	514,3	600,0	685,7
	90°	385,7	514,3	642,9	720,0	771,4	900,0	1028,6
DAN 1440	0°	768,0	1027,2	1286,4	1440,0	1545,6	1804,8	2057,4
	50°	384,0	518,4	643,2	720,0	768,0	902,4	1059,2
	90°	576,0	777,6	969,9	1080,0	1161,6	1353,6	1545,6
DAN 1920	0°	1028,6	1371,4	1714,3	1920,0	2057,1	2400,0	2742,9
	50°	514,3	685,8	857,1	960,0	1028,6	1200,0	1371,4
	90°	771,4	1028,6	1285,7	1440,0	1542,9	1800,0	2057,1
DA 2880	0°	1543	2057	2571,4	2880	3085,7	3600	4114,3
	50°	771,4	1028,6	1285,7	1440	1543	1800	2057,1
	90°	1157	1543	1928,6	2160	2314,3	2700	3085,7
DA 3840	0°	2050	2840	3425	3840,0	4110	4880,0	5485
	50°	1025	1370	1710	1920,0	2055	2400,0	2740
	90°	1540	2055	2570	2880,0	3085	3600,0	4014
DA 5760	0°	3085,7	4114,3	5143	5760	6171,4	7200	8228,6
	50°	1542,9	2057	2571,4	2880	3085,7	3600	4114,3
	90°	2314,3	3085,7	3857,1	4320	4628,6	5400	6171,4
DA 8000	0°	4285,7	5714,3	7142,9	8000	8571,4	10000	
	50°	2142,9	2857,1	3571,4	4000	4285,7	5000	
	90°	3214,3	4285,7	5357,1	6000	6428,6	7500	

# Codes, dimensions and materials - DA8

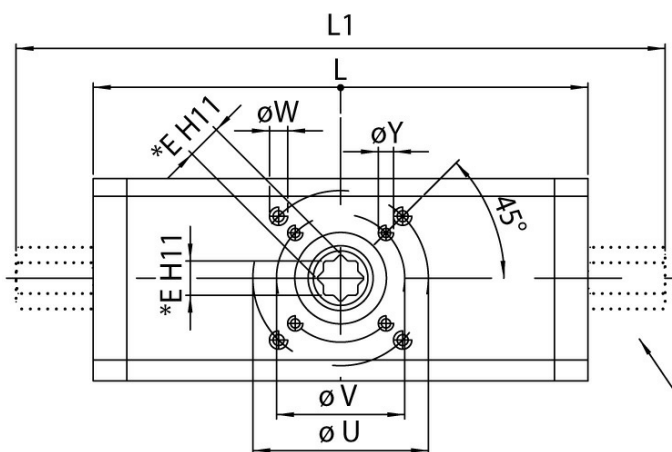

Dispositivo di regolazione della  
caorsa (max 10°)  
Manual stroke adjustment (max 10°)

INTERFACCIA NAMUR  
NAMUR INTERFACE

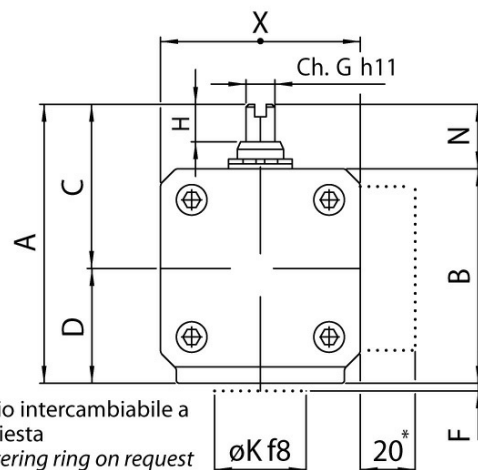
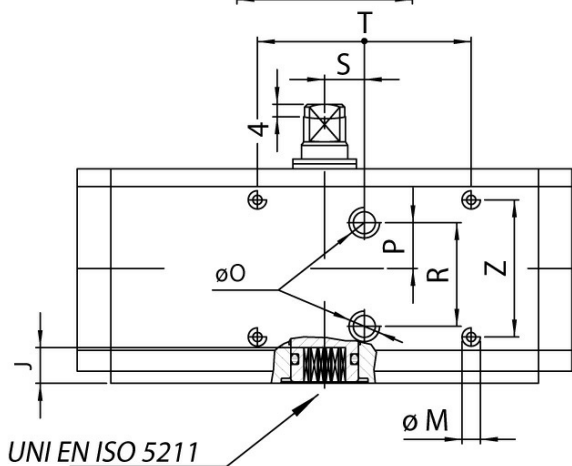
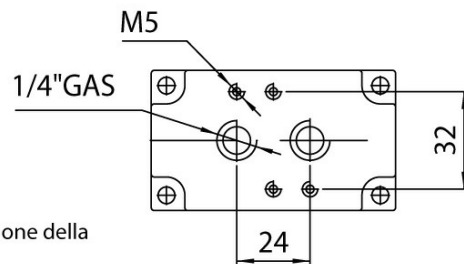

Anello di centraggio intercambiabile a  
richiesta  
Interchangeable centering ring on request

Q (N°4 FILETTI M5)  
Q (N°4 THREAD M5)

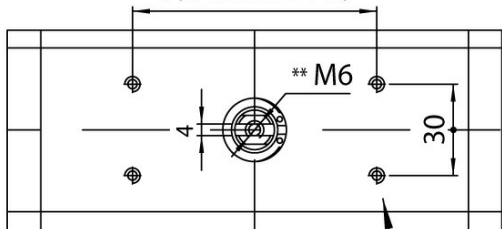

\*\* DA 8 filetto M4  
\*\* DA 8 thread M4

Interfaccia per accessori  
secondo VDI/VDE 3845, EN 15714-3  
Accessories interface  
VDI/VDE 3845, EN 15714-3

\*Per le misure DA8-DA360 è disponibile a  
richiesta una bassetta con interfaccia NAMUR  
\*Sizes from DA8 to DA360 can be provided  
with NAMUR plate on request

## DIMENSION TABLE

code	DA008401S
code adj. 10°	---
Spare seals	KGDI0010
<b>size</b>	<b>DA 8F03</b>
L mm.	70
L1 mm.	---
A mm.	57,7
B mm.	42,7
X mm.	43,2
C mm.	35

D mm.	22,7
E mm.	9
J mm.	9,5
G mm.	8
H mm.	8
N mm.	15
øM x depth. mm.	M 5x5
øO thread GAS	1/8"
P mm.	11,5
Q mm.	30
R mm.	23
S mm.	5
T mm.	25
øU mm.	---
øV mm.	36
øK mm.	25
F mm.	2
øY x depth. mm.	M 5x8
øW x depth. mm.	---
Z mm.	30
air dm <sup>3</sup> /cycle	0,034
weight Kg.	0,29

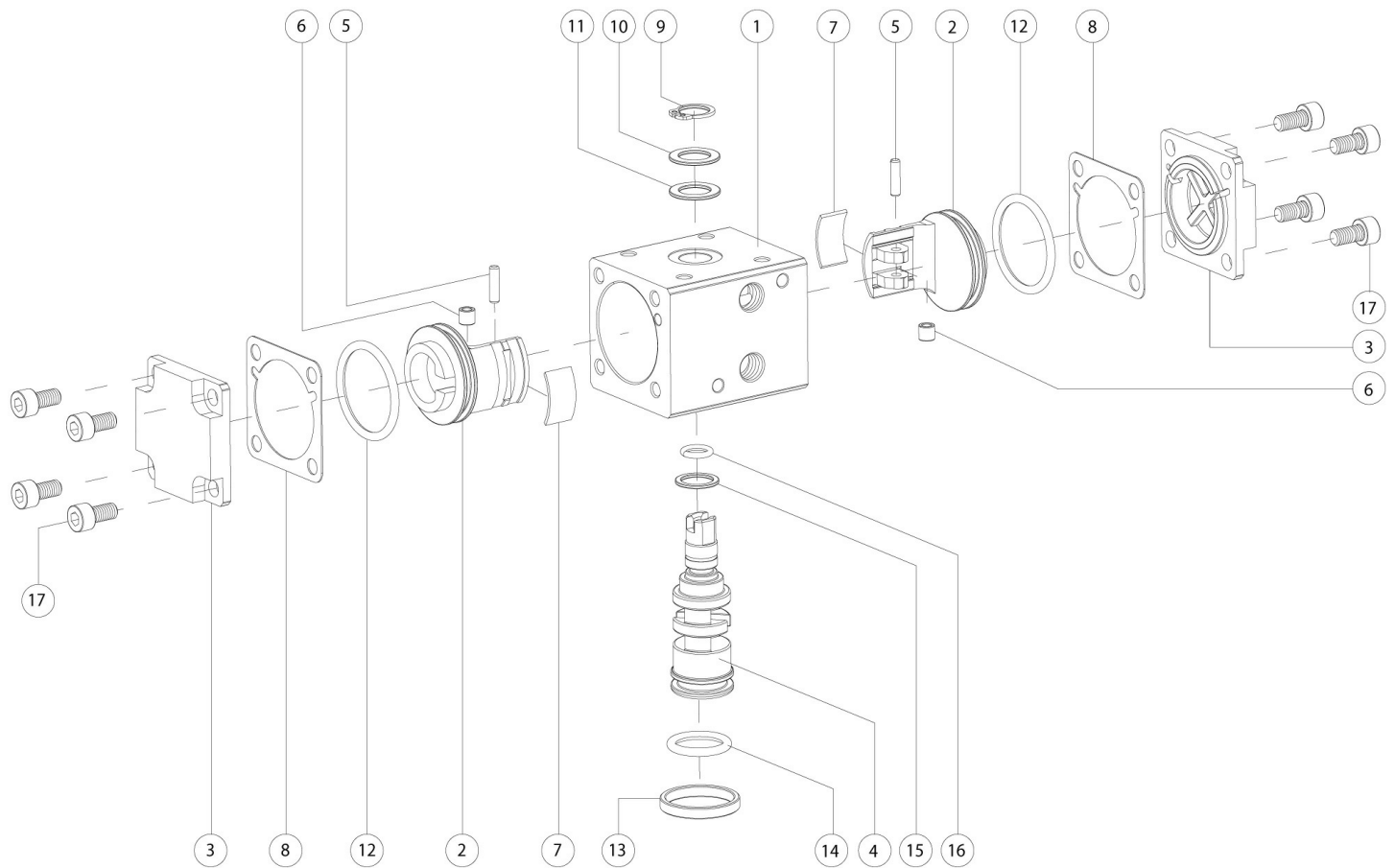

#### MATERIALS SPECIFICATION

Pos	Denomination	Q.TA' Q.ty	Material
1	Cylinder	1	Aluminium alloy
2	Piston	2	Aluminium alloy
3	Cap DA	2	Aluminium alloy
4	Shaft	1	Steel alloy
5	Sleeve	2	Steel alloy
6	Bush	2	Steel alloy
7*	Support band	2	Acetalic resins
8*	O-ring	2	NBR
9	Seeger	1	Stainless steel
10	Washer	1	Stainless steel
11*	Ext. support ring	1	Acetalic resins
12*	O-ring	2	NBR
13	Center ring F03	1	Alluminium alloy
14*	O-ring	1	FKM
15*	Int.support ring	1	Acetalic resins
16*	O-ring	1	FKM
17	Screw	8	Stainless steel

\*Components of spare part kit



# Codes, dimensions and materials - DA15

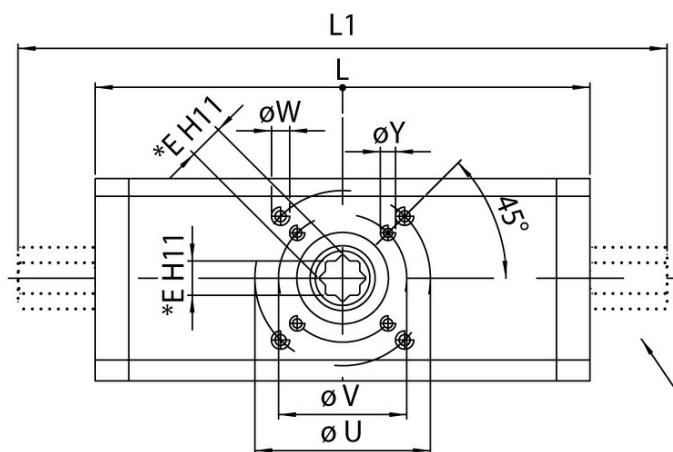

Dispositivo di regolazione della  
caorsa (max 10°)  
Manual stroke adjustment (max 10°)

INTERFACCIA NAMUR  
NAMUR INTERFACE

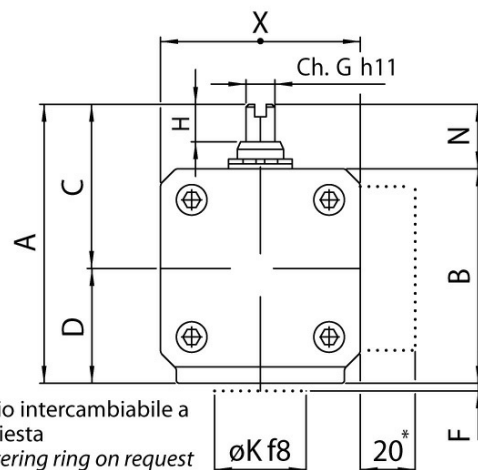
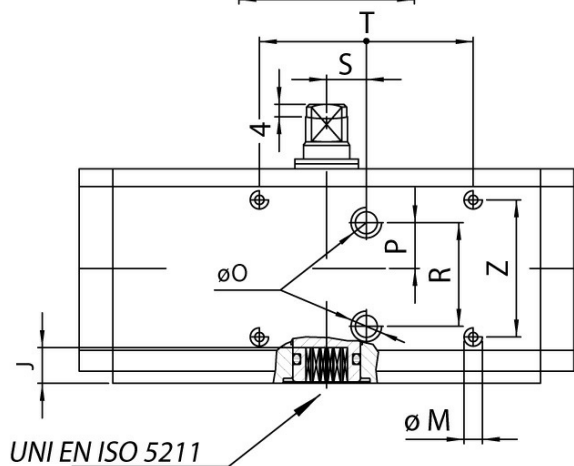
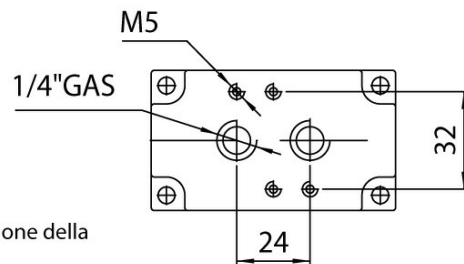

Anello di centraggio intercambiabile a  
richiesta  
Interchangeable centering ring on request

Q (N°4 FILETTI M5)  
Q (N°4 THREAD M5)

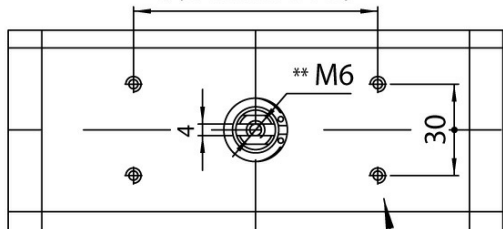

\*\* DA 8 filetto M4  
\*\* DA 8 thread M4

Interfaccia per accessori  
secondo VDI/VDE 3845, EN 15714-3  
Accessories interface  
VDI/VDE 3845, EN 15714-3

\*Per le misure DA8-DA360 è disponibile a  
richiesta una bassetta con interfaccia NAMUR  
\*Sizes from DA8 to DA360 can be provided  
with NAMUR plate on request

## DIMENSION TABLE

code	DA015401S
code adj. 10°	DA015411S
Spare seals	KGDI0012
<b>size</b>	<b>DA 15 F03</b>
L mm.	115
L1 mm.	160
A mm.	72,4
B mm.	52
X mm.	48

C mm.	44,2
D mm.	28,2
E mm.	9
J mm.	10,2
G mm.	8
H mm.	10
N mm.	20
øM x depth. mm.	M 5x10
øO thread GAS	1/8"
P mm.	9
Q mm.	80
R mm.	20,5
S mm.	6
T mm.	70
øU mm.	---
øV mm.	36
øK mm.	25
F mm.	2
øY x depth. mm.	M 5x9
øW x depth. mm.	---
Z mm.	30
air dm <sup>3</sup> /cycle	0,079
weight Kg.	0,73

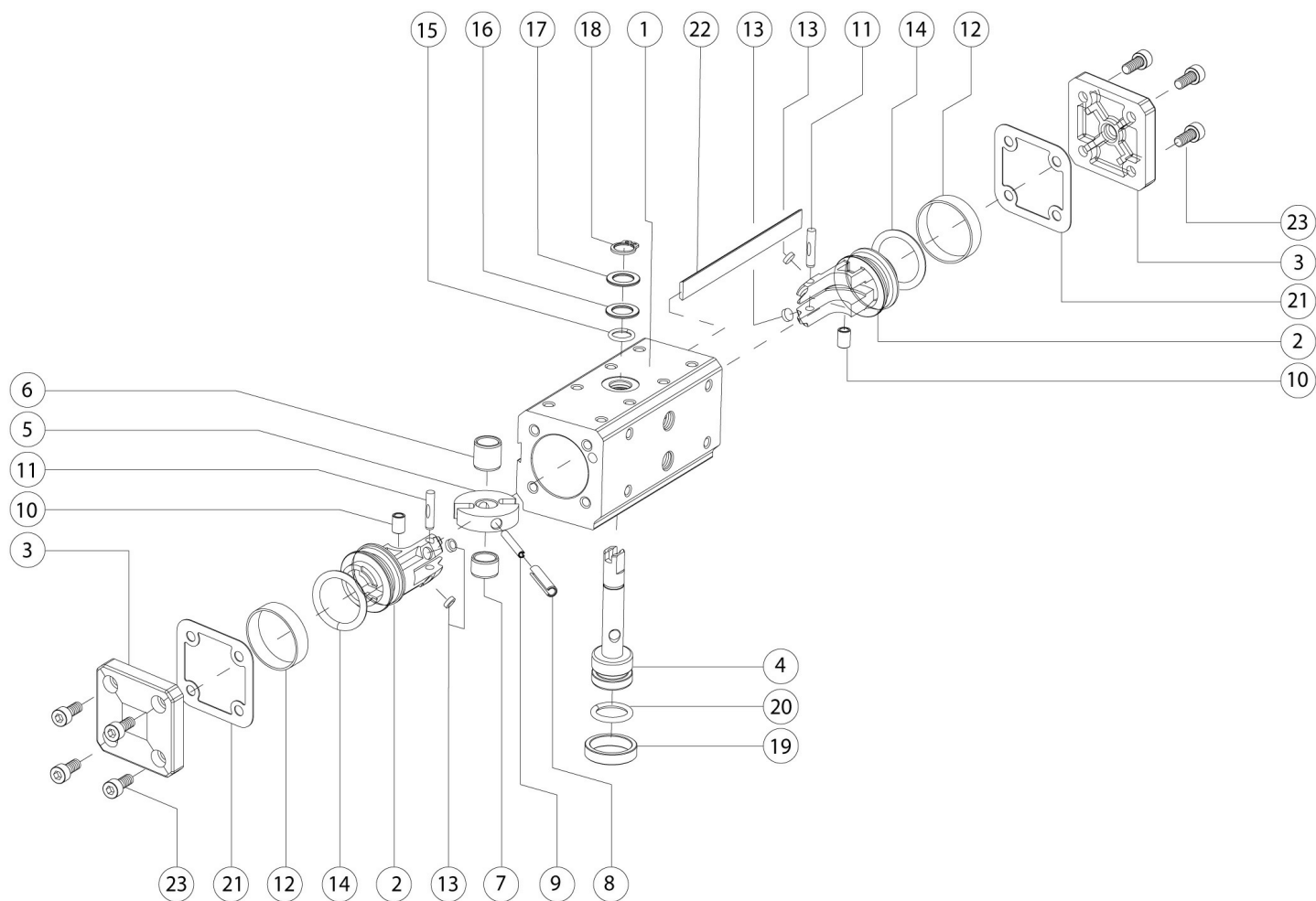

#### MATERIALS SPECIFICATION

Pos	Denomination	Q.ty	Material
1	Cylinder	1	Aluminium alloy
2	Piston	2	Aluminium alloy
3	Cap DA	2	Aluminium alloy
4	Shaft	1	Stainless steel
5	Scotch yoke	1	Steel alloy
6	Bush	1	Acetalic resins
7	Bush	1	Acetalic resins
8	Ext. elastic pin	1	Steel alloy
9	Int. elastic pin	1	Steel alloy
10	Bush	2	Steel alloy
11	Sleeve	2	Steel alloy
12*	Dynamic seal	2	Polyurethan
13*	suppoert disk	4	Carbo-graphite filled PTFE
14*	O-ring	2	NBR
15*	O-ring	1	Viton
16*	Ext. support ring	1	Acetalic resins
17	Washer	1	Stainless steel
18	Seeger	1	Stainless steel
19	Center ring F03	1	Aluminium alloy

20*	O-ring	1	Viton
21*	Gasket	2	AFM-38
22	Plate	1	Aluminium
23	Screw	8	Stainless steel

\*Components of spare part kit

# Codes, dimensions and materials - DA30 - DA360

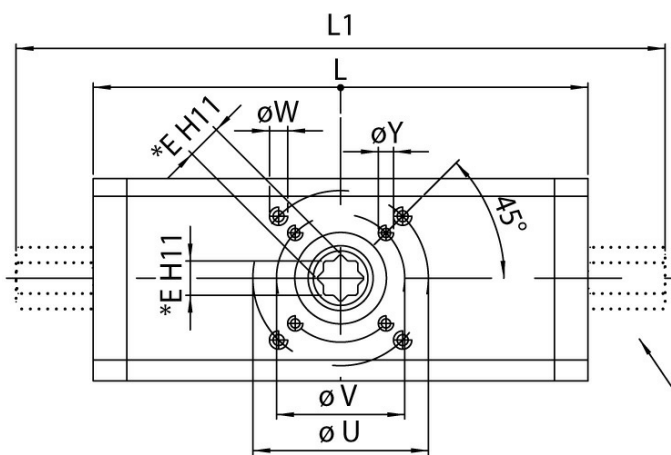

Dispositivo di regolazione della corsa (max 10°)  
Manual stroke adjustment (max 10°)

INTERFACCIA NAMUR  
NAMUR INTERFACE

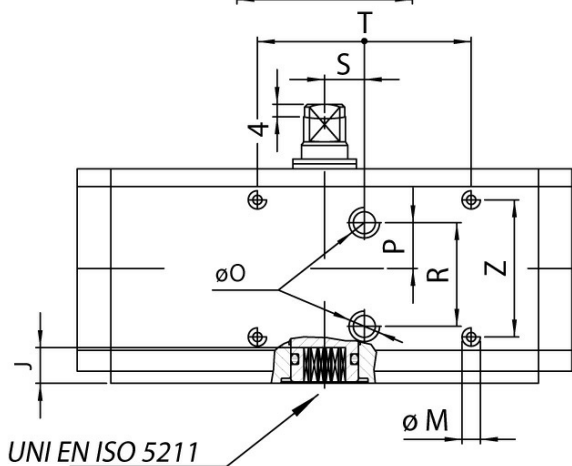
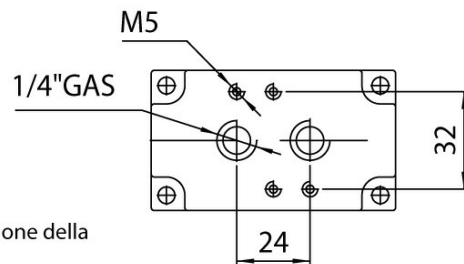

UNI EN ISO 5211

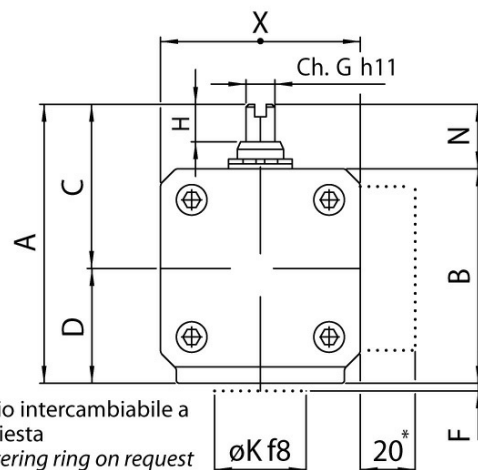

Anello di centraggio intercambiabile a richiesta  
Interchangeable centering ring on request

Q (N°4 FILETTI M5)  
Q (N°4 THREAD M5)

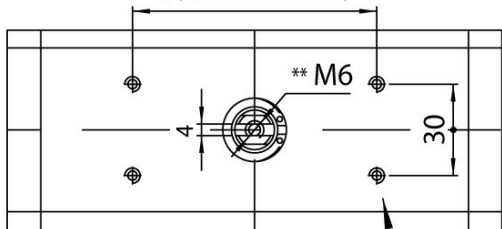

\*\* DA 8 filetto M4  
\*\* DA 8 thread M4

Interfaccia per accessori secondo VDI/VDE 3845, EN 15714-3  
Accessories interface VDI/VDE 3845, EN 15714-3

\*Per le misure DA8-DA360 è disponibile a richiesta una bassetta con interfaccia NAMUR  
\*Sizes from DA8 to DA360 can be provided with NAMUR plate on request

## DIMENSION TABLE

code	DA030401S	DA045401S	DA045402S	DA060401S	DA060402S
code adj. 10°	DA030411S	DA045411S	DA045412S	DA060411S	DA060412S
Spare seals	KGDI0014	KGDI0015	KGDI0015	KGDI0016	KGDI0016
size	<b>DA 30</b> <b>F03 - F05</b>	<b>DA 45</b> <b>F04</b>	<b>DA 45</b> <b>F03 - F05</b>	<b>DA 60</b> <b>F04</b>	<b>DA 60</b> <b>F03 - F05</b>
L mm.	130	144	144	152	152
L1 mm.	168	182	182	190	190
A mm.	80,4	85,7	85,7	90,4	90,4
B mm.	60	65,7	65,7	70	70
X mm.	55	60	60	65	65

C mm.	47,5	50	50	52,5	52,5
D mm.	32,7	35,7	35,7	37,7	37,7
E mm.	9	11	11	11	11
J mm.	10,2	12,2	12,2	12,2	12,2
G mm.	9	10	10	10	10
H mm.	10	13	13	13	13
N mm.	20	20	20	20	20
øM x depth. mm.	M 5x6	M 5x6	M 5x6	M 5x6	M 5x6
øO thread GAS	1/8"	1/8"	1/8"	1/8"	1/8"
P mm.	12	12,5	12,5	17,9	17,9
Q mm.	80	80	80	80	80
R mm.	25	25	25	20,5	20,5
S mm.	0	0	0	0	0
T mm.	70	70	70	70	70
øU mm.	50	---	50	---	50
øV mm.	36	42	36	42	36
øK mm.	25-35	30	25-35	30	25-35
F mm.	2	2	2	2	2
øY x depth. mm.	M 5x9	M 5x9	M 5x9	M 5x9	M 5x9
øW x depth. mm.	M 6x11	---	M 6x11	---	M 6x11
Z mm.	36	36	36	36	36
air dm <sup>3</sup> /cycle	0,148	0,219	0,219	0,28	0,28
weight Kg.	1	1,25	1,25	1,56	1,56

code	DA090401S	DA120401S	DA180401S	DA240401S	DA360401S
code adj. 10°	DA090411S	DA120411S	DA180411S	DA240411S	DA360411S
Spare seals	KGDI0017	KGDI0018	KGDI0019	KGDI0020	KGDI0021
<b>size</b>	<b>DA 90 F05 - F07</b>	<b>DA 120 F05 - F07</b>	<b>DA 180 F05 - F07</b>	<b>DA 240 F05 - F07</b>	<b>DA 360 F07 - F10</b>
L mm.	169	184	212	242	264
L1 mm.	225	240	268	314	336
A mm.	97,5	116,4	126	136,4	148
B mm.	77,5	86	96	106	118
X mm.	75	80	90	100	112
C mm.	56,5	70	75	80	86
D mm.	41,5	46,4	51	56,4	62
E mm.	14	14	17	17	22
J mm.	16,3	16,3	19,3	19,3	24,3
G mm.	12	12	15	15	19
H mm.	13	13	16	17	19

N mm.	20	30	30	30	30
øM x depth. mm.	M 5x6	M 5x6	M 5x6	M 5x6	M 5x6
øO thread GAS	1/8"	1/8"	1/8"	1/8"	1/8"
P mm.	17,9	21	21	21	25
Q mm.	80	80	80	80	80
R mm.	20,5	25	25	25	25
S mm.	0	0	0	0	0
T mm.	70	70	70	70	70
øU mm.	70	70	70	70	102
øV mm.	50	50	50	50	70
øK mm.	35-55	35-55	35-55	35-55	55-70
F mm.	3	3	3	3	3
øY x depth. mm.	M 6x11	M 6x11	M 6x11	M 6x11	M 8x15
øW x depth. mm.	M 8x15	M 8x15	M 8x15	M 8x15	M 10x17
Z mm.	36	36	36	36	36
air dm <sup>3</sup> /cycle	0,43	0,59	0,87	1,18	1,74
weight Kg.	1,85	2,8	3,4	5,3	7,2

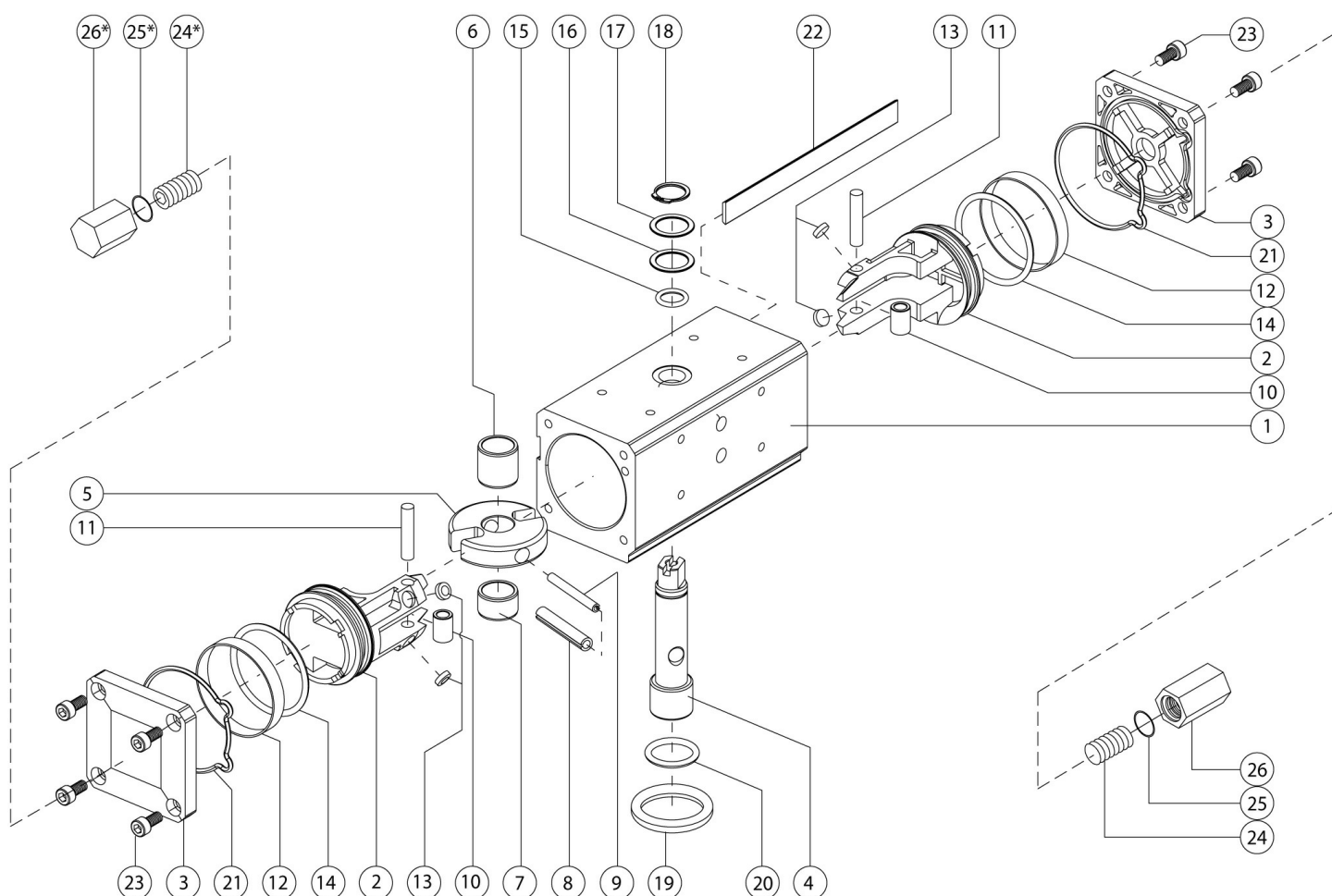

#### MATERIALS SPECIFICATION

Pos	Denomination	Q.ty	Material
1	Cylinder	1	Aluminium alloy

2	Piston	2	Aluminium alloy
3	Cap DA	2	Aluminium alloy
4	Shaft	1	Stainless steel
5	Scotch yoke	1	Steel alloy
6	Bush	1	Resina acetalica Acetalic resins
7	Bush	1	Resina acetalica Acetalic resins
8	Ext. elastic pin	1	Steel alloy
9	Int. elastic pin	1	Steel alloy
10	Bush	2	Steel alloy
11	Sleeve	2	Steel alloy
12**	Dynamic seal	2	Polyurethan
13**	support disk	4	Carbo-graphite filled PTFE
14**	O-ring	2	NBR
15**	O-ring	1	FKM
16**	Ext.support ring	1	Resina acetalica Acetalic resins
17	Washer	1	Stainless steel
18	Seeger	1	Stainless steel
19	Center ring F03	1	Aluminium alloy
20**	O-ring	1	FKM
21**	O-ring	2	NBR
22	Plate	1	Aluminium
23	Screws	8	Stainless steel
24*	Grub screws	2	Stainless steel
25*	O-ring	2	Gomma nitrilica NBR
26*	Adjusting nut	2	Aluminium alloy

\* Actuator with regulation Code: DA\_\_411

\*\*Components of spare part kit



# Codes, dimensions and materials - DA480

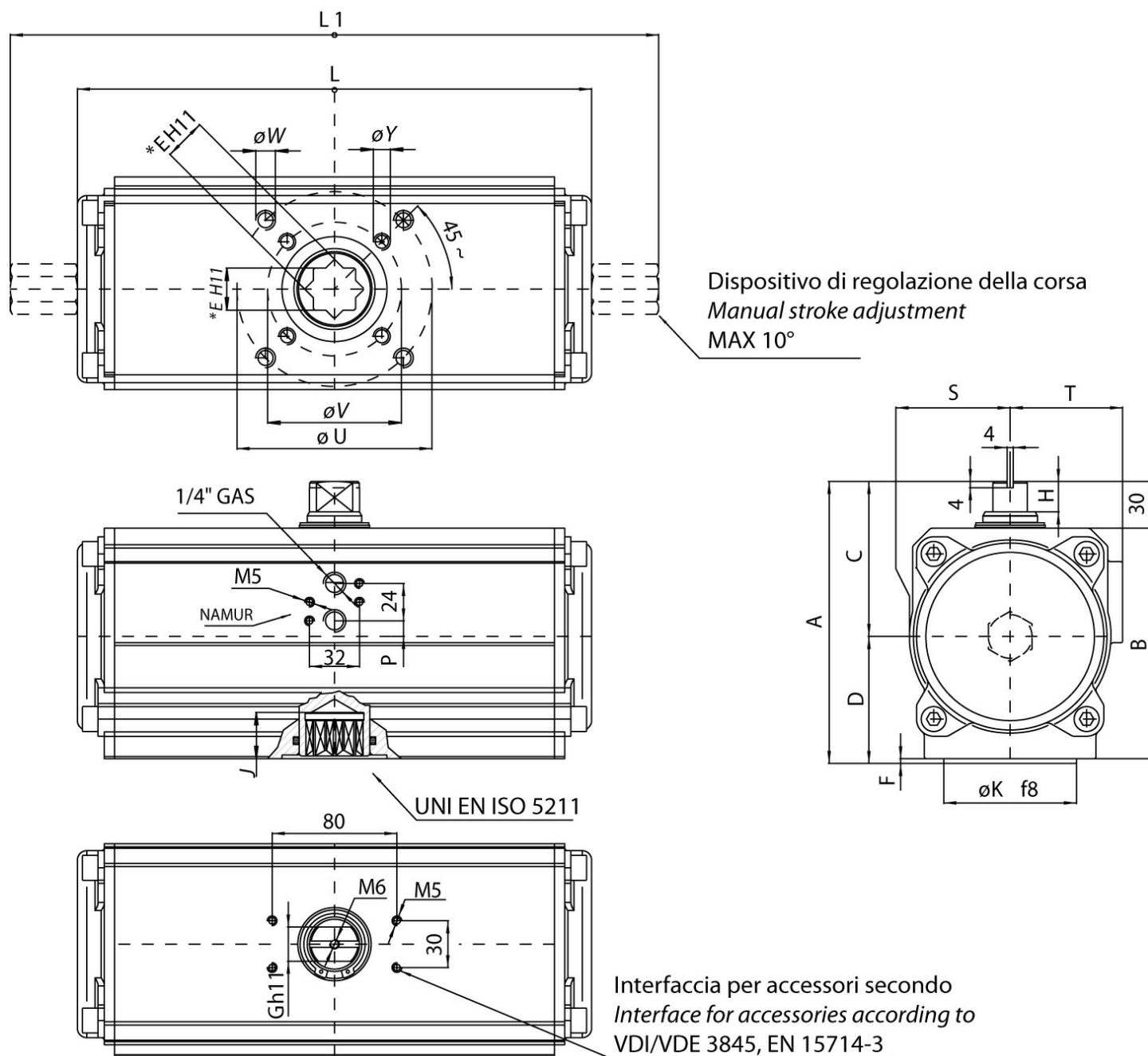

## DIMENSION TABLE

code	DA480401S
code adj.10°	DA480411S
Spare seals	KGDI0022
<b>size</b>	<b>DA 480 F07-F10</b>
L mm.	295
L1 mm.	365
A mm.	160
B mm.	130
S mm.	57,7
T mm.	67

C mm.	92
D mm.	68
E mm.	22
J mm.	24,3
G mm.	19
H mm.	19
P mm.	2
øU mm.	102
øV mm.	70
øK mm.	55-70
F mm.	3
øY x prof. depth mm.	M 8x15
øW x prof. depth mm.	M 10x17
air dm <sup>3</sup> /cycle	2,38
weight Kg.	8,4

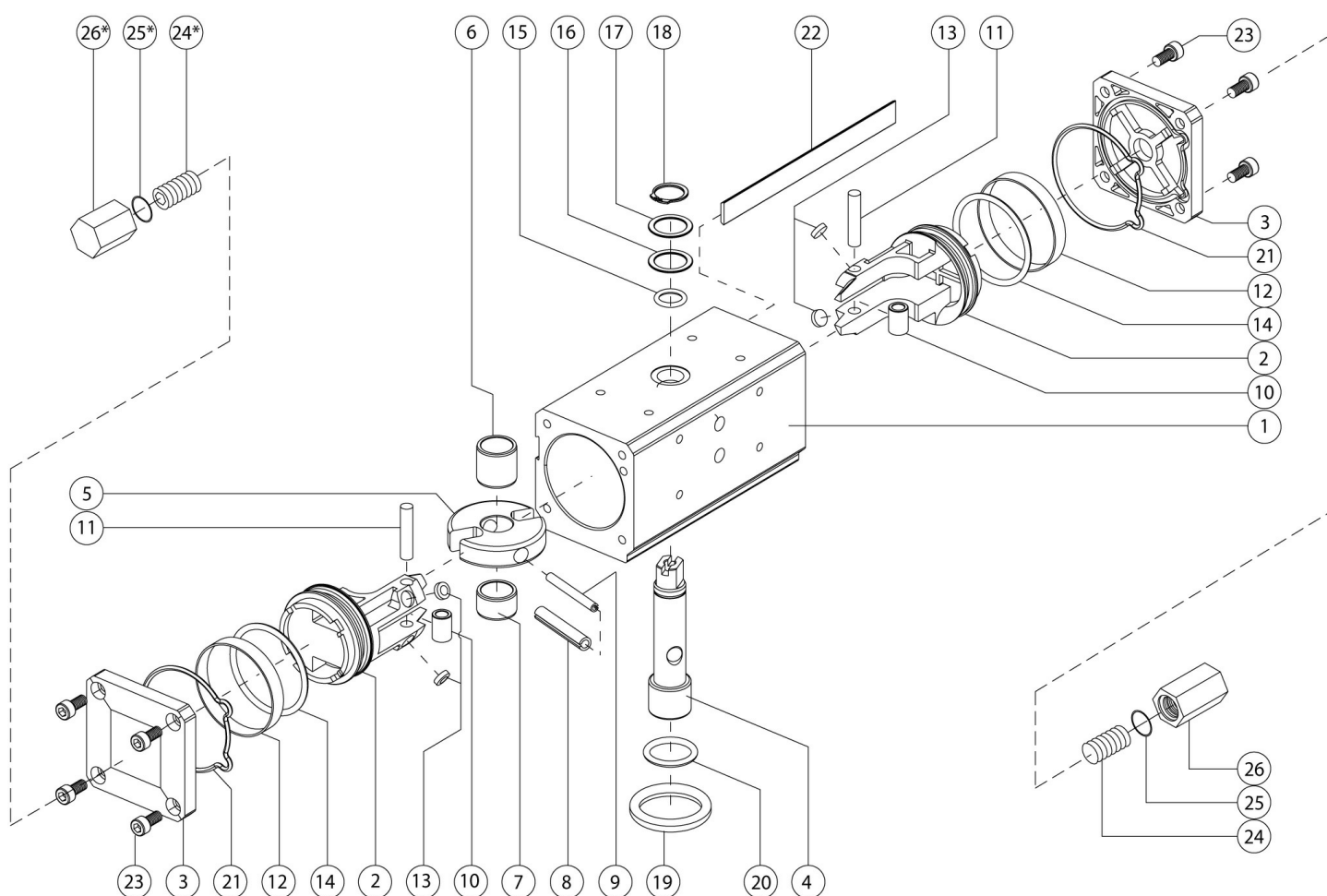

#### MATERIALS SPECIFICATION

Pos	Denomination	Q.ty	Material
1	Cylinder	1	Aluminium alloy
2	Piston	2	Aluminium alloy
3	Cap DA	2	Aluminium alloy

4	Shaft	1	Stainless steel
5	Scotch yoke	1	Steel alloy
6	Bush	1	Acetalic resins
7	Bush	1	Acetalic resins
8	Ext. elastic pin	1	Steel alloy
9	Int. elastic pin	1	Steel alloy
10	Bush	2	Steel alloy
11	Sleeve	2	Steel alloy
12**	Dynamic seal	2	Polyurethan
13**	suppoert disk	4	Carbo-graphite filled PTFE
14**	O-ring	2	NBR
15**	O-ring	1	Viton
16**	Ext. support ring	1	Acetalic resins
17	Washer	1	Stainless steel
18	Seeger	1	Stainless steel
19	Center ring F03	1	Aluminium alloy
20**	O-ring	1	Viton
21**	Gasket	2	AFM-38
22	Plate	1	Aluminium
23	Screw	8	Stainless steel
24*	Grub screw	2	Stainless steel
25*	O-ring	2	NBR
26*	Adjusting nut	2	Alluminium alloy

\* Actuator with regulation Code: DA\_\_\_411

\*\*Components of spare part kit

# Codes, dimensions and materials - DA720

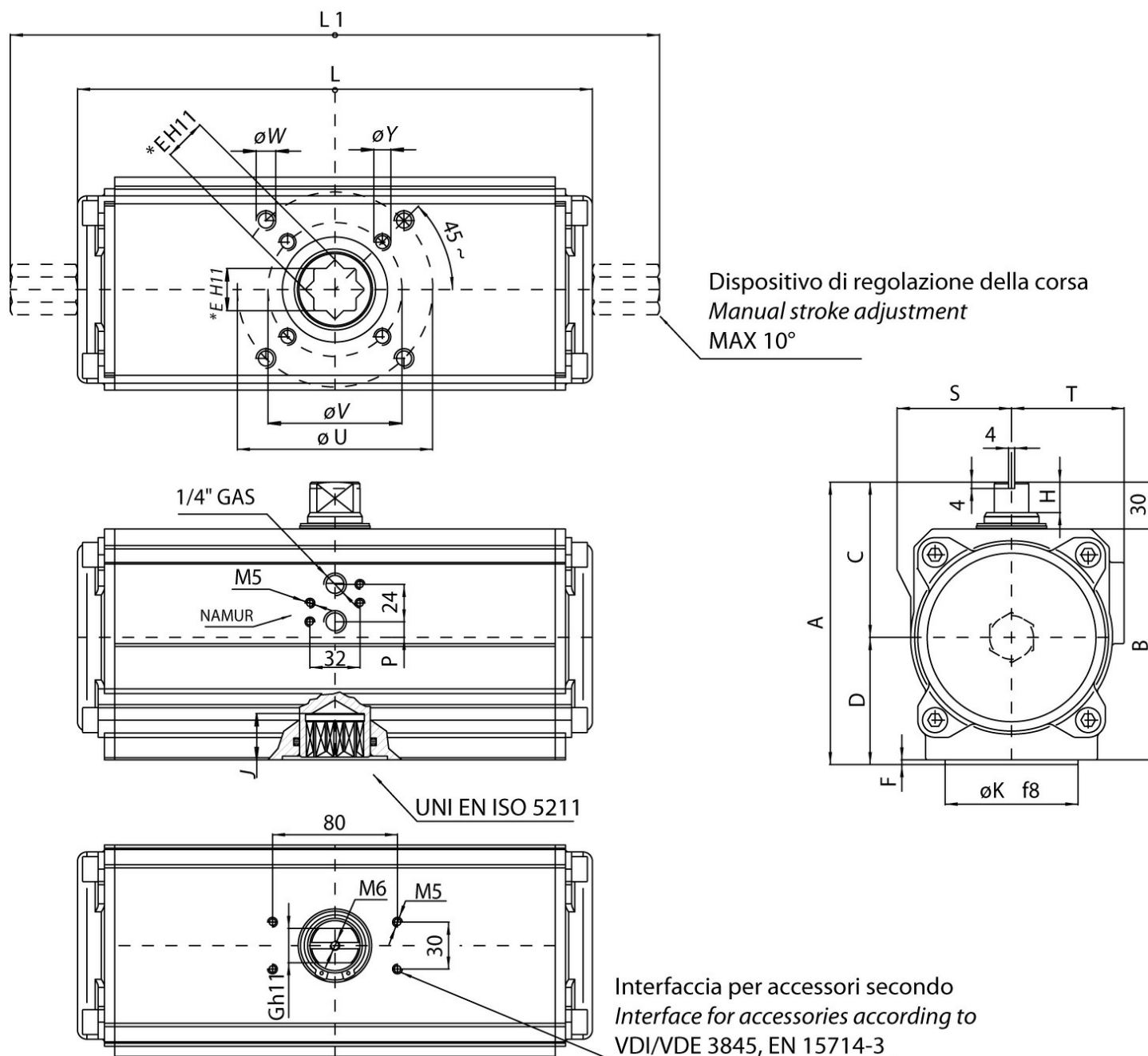

## DIMENSION TABLE

code	DA720401S
code adj.10°	DA720411S
Spare seals	KGDI0023
<b>size</b>	<b>DA 720 F10-F12</b>
L mm.	329,5
L1 mm.	401,5
A mm.	178
B mm.	148
S mm.	64,5
T mm.	72

C mm.	99,5
D mm.	78,5
E mm.	27
J mm.	29,5
G mm.	22
H mm.	19,5
P mm.	10
øU mm.	125
øV mm.	102
øK mm.	70-85
F mm.	3
øY x prof. depth mm.	M 10x17
øW x prof. depth mm.	M 12x21
air dm <sup>3</sup> /cycle	3,51
weight Kg.	12

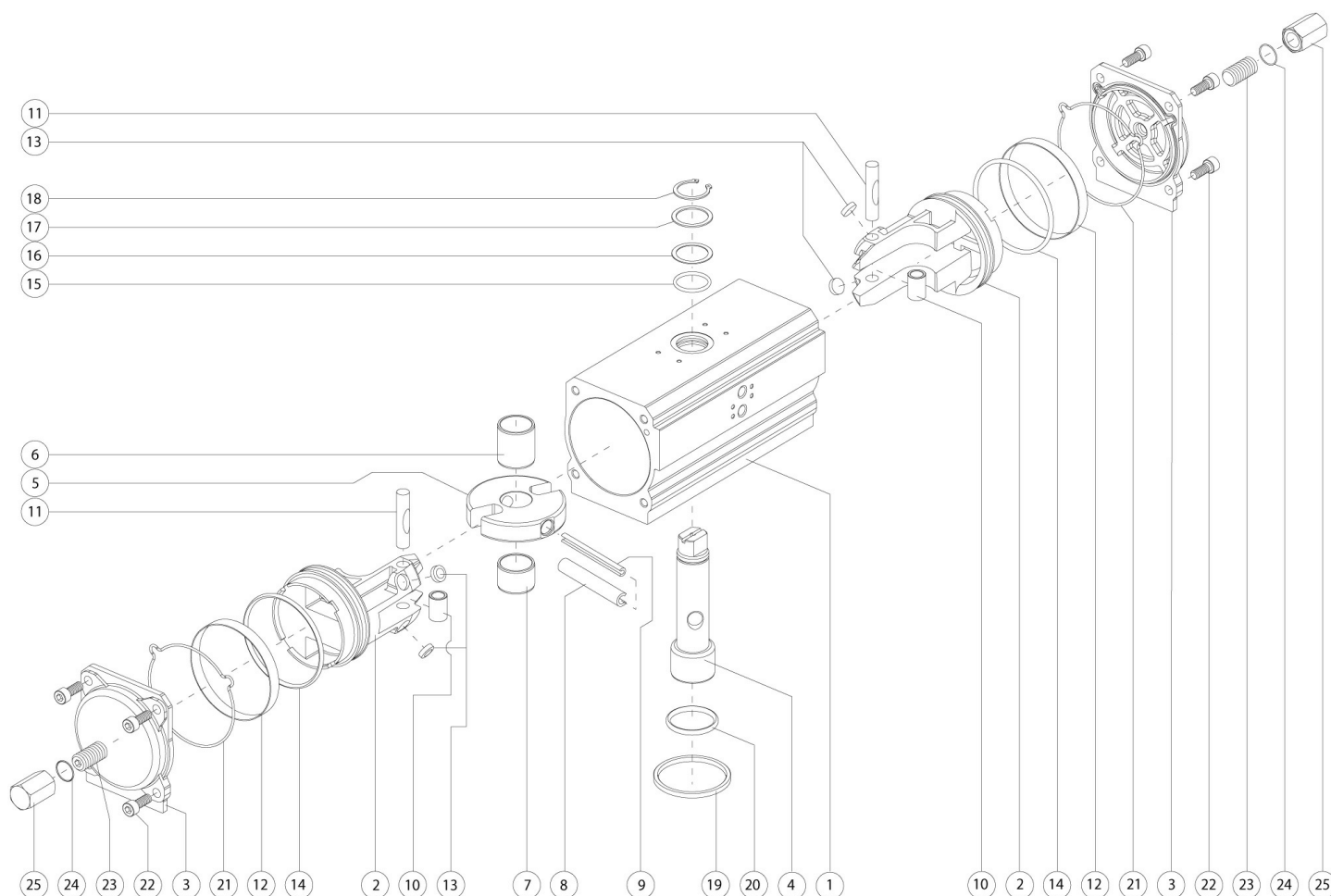

#### MATERIALS SPECIFICATION

Pos	Denomination	Q.ty	Material
1	Cylinder	1	Aluminium alloy
2	Pyston	2	Aluminium alloy
3	Cap DA	2	Aluminium alloy

4	Shaft	1	Stainless steel
5	Scotch yoke	1	Steel alloy
6	Bush	1	Acetalic resins
7	Bush	1	Acetalic resins
8	Ext. elastic pin	1	Steel alloy
9	Int. elastic pin	1	Steel alloy
10	Bush	2	Steel alloy
11	Sleeve	2	Steel alloy
12**	Dynamic seal	2	Polyurethan
13**	Support disk	4	Carbo-graphite filled PTFE
14**	O-ring	2	NBR
15**	O-ring	1	Viton
16**	Ext.support ring	1	Acetalic resins
17	Washer	1	Stainless steel
18	Seeger	1	AISI 420
19	Center ring F12	1	Aluminium alloy
20**	O-ring	1	Viton
21**	O-ring	2	NBR
22	Screws	8	Stainless steel
23*	Grub screws	2	Steel alloy
24*	O-ring	2	NBR
25*	Adjusting nut	2	Aluminium alloy
* Actuator with regulation Code: DA__411			

\*\*Components of spare part kit

# Codes, dimensions and materials - DA960

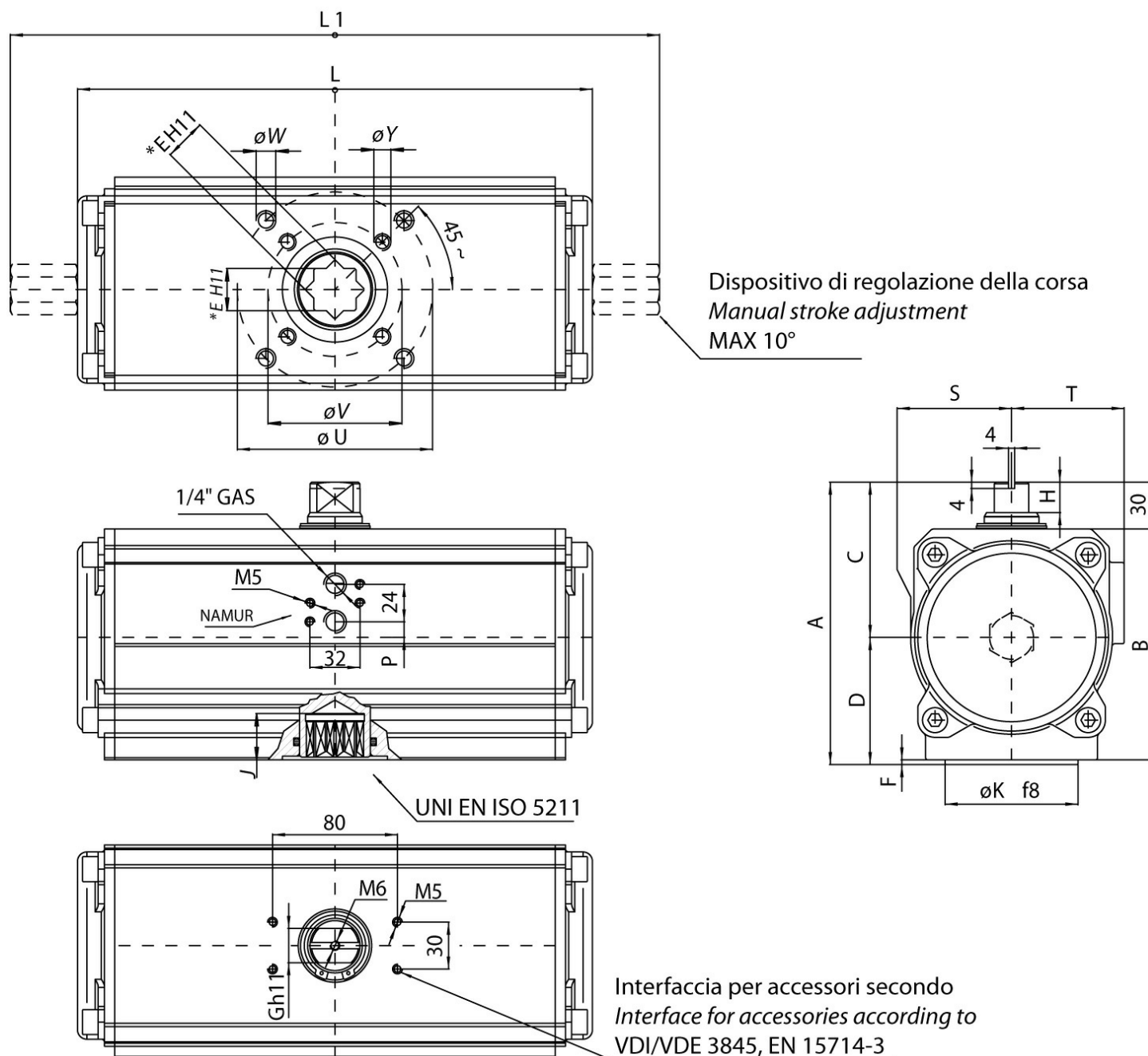

## DIMENSION TABLE

code	DA960401S
code adj.10°	DA960411S
Spare seals	KGDI0024
<b>size</b>	<b>DA 960 F12</b>
L mm.	377
L1 mm.	445
A mm.	186,2
B mm.	153
S mm.	69
T mm.	76

C mm.	100,3
D mm.	86,2
E mm.	27
J mm.	29,5
G mm.	24
H mm.	19,5
P mm.	14
øU mm.	----
øV mm.	125
øK mm.	85
F mm.	3
øY x prof. depth mm.	M 12x21
øW x prof. depth mm.	----
air dm <sup>3</sup> /cycle	4,67
weight Kg.	14

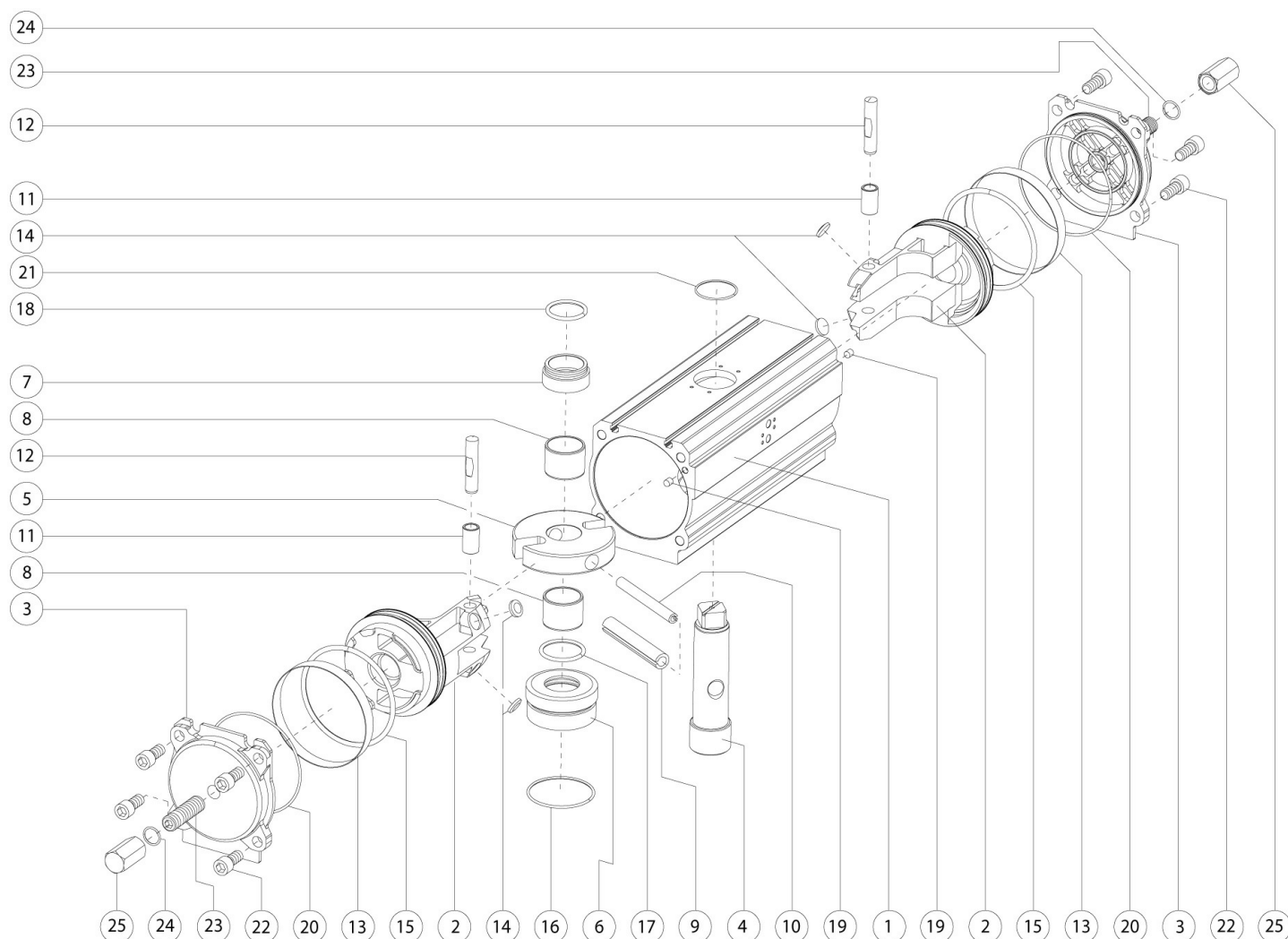

**MATERIALS SPECIFICATION**

Pos	Denomination	Q.TA' Q.ty	Material
1	Cylinder	1	Aluminium alloy



2	Pyston	2	Aluminium alloy
3	Cap DA	2	Aluminium alloy
4	Shaft	1	Stainless steel
5	Scotch yoke	1	Stainless steel
6	Bush	1	Aluminium alloy
7	Bush	1	Aluminium alloy
8	Bush	2	Acetalic resins
9	Ext. elastic pin	1	Stainless steel
10	Int. elastic pin	1	Stainless steel
11	Bush	2	Stainless steel
12	Sleeve	2	Stainless steel
13**	Dynamic seal	2	Polyurethan
14**	Support disk	4	Carbo-graphite filled PTFE
15**	O-ring	2	NBR
16	O-ring	1	NBR
17**	O-ring	1	Viton
18**	O-ring	1	Viton
19	Plug	2	NBR
20**	O-ring	2	NBR
21	O-ring	1	NBR
22	screws	8	Stainless steel
23*	Grub screws	2	Stainless steel
24*	O-ring	2	Gomma nitrilica NBR
25*	Adjusting nut	2	Aluminium alloy

\* Actuator with regulation Code: DA\_\_\_411

\*\*Components of spare part kit

# Codes, dimensions and materials - DAN1440 - DAN1920

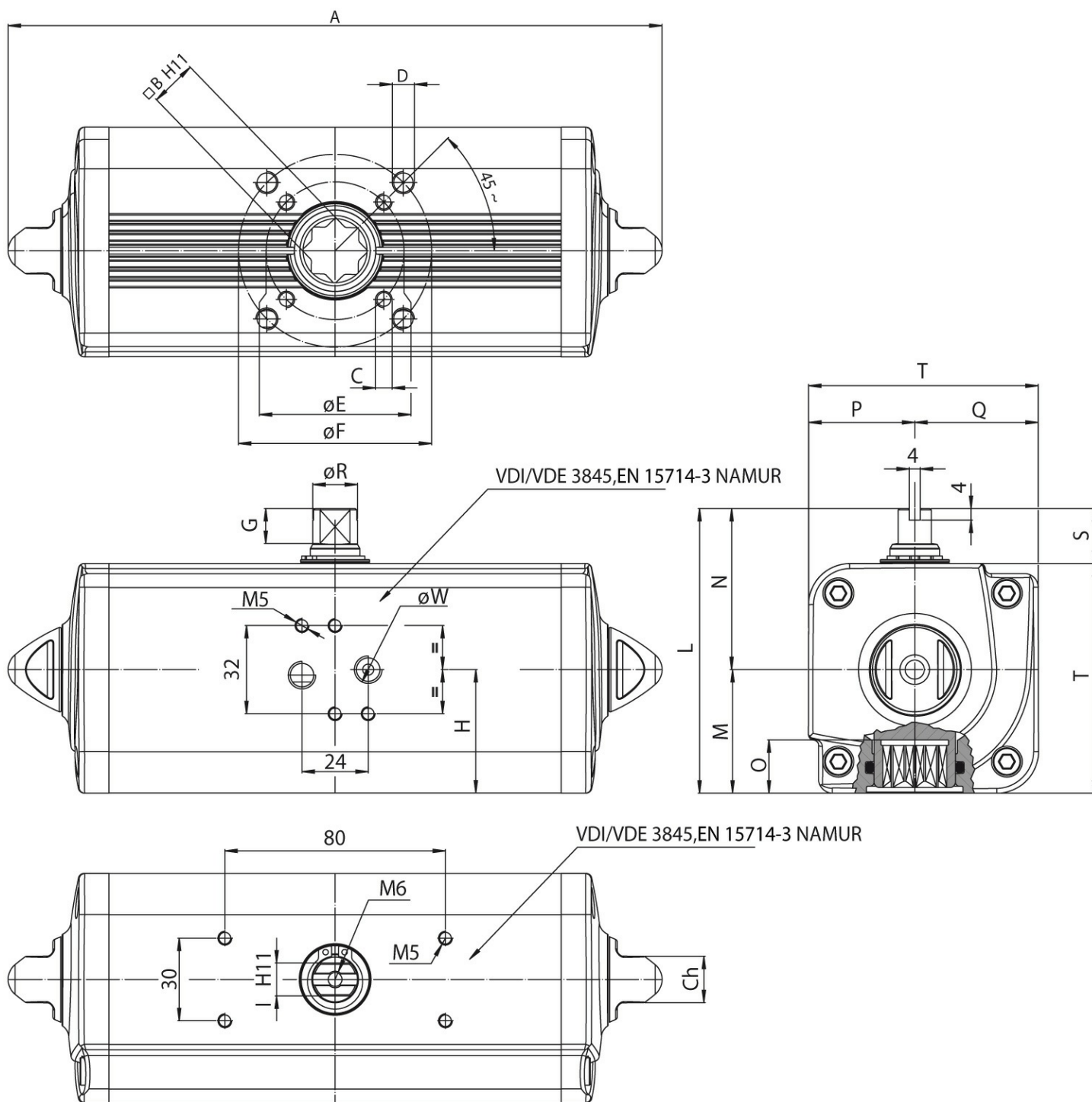

## DIMENSION TABLE

CODE	DAN1440412S	DAN1440411S	DAN1920412S	DAN1920411S
Spare seals	KGGI0025	KGGI0025	KGGI0026	KGGI0026
size	<b>DAN1440 F12</b>	<b>DAN1400 F14</b>	<b>DAN1920 F12/F16</b>	<b>DAN1920 F14</b>
A	567	567	601	601
B	36	36	46	46
C x depth	M12x18	M16x24	M12x18	M16x24
D x depth	-	-	M20x30	-
E	125	140	125	140

F	-	-	165	-
G	19,5	19,5	18,5	18,5
H	86,5	86,5	99,2	99,2
I	27	27	32	32
L	216	216	237,7	237,7
M	101,5	101,5	114,7	114,7
N	114,5	114,5	123	123
O	38,5	38,5	48,5	48,5
P	84,5	84,5	93	93
Q	101,5	101,5	114,7	114,7
R	41	41	46	46
S	30	30	30	30
T	186	186	207,7	207,7
W (Gas)	1/4"	1/4"	1/4"	1/4"
Ch	36	36	36	36
Weight (Kg)	23,4	23,4	32	32
air dm <sup>3</sup> /cycle	7,6	7,6	10,2	10,2

**H = CENTER OF PLATE'S FIXING**

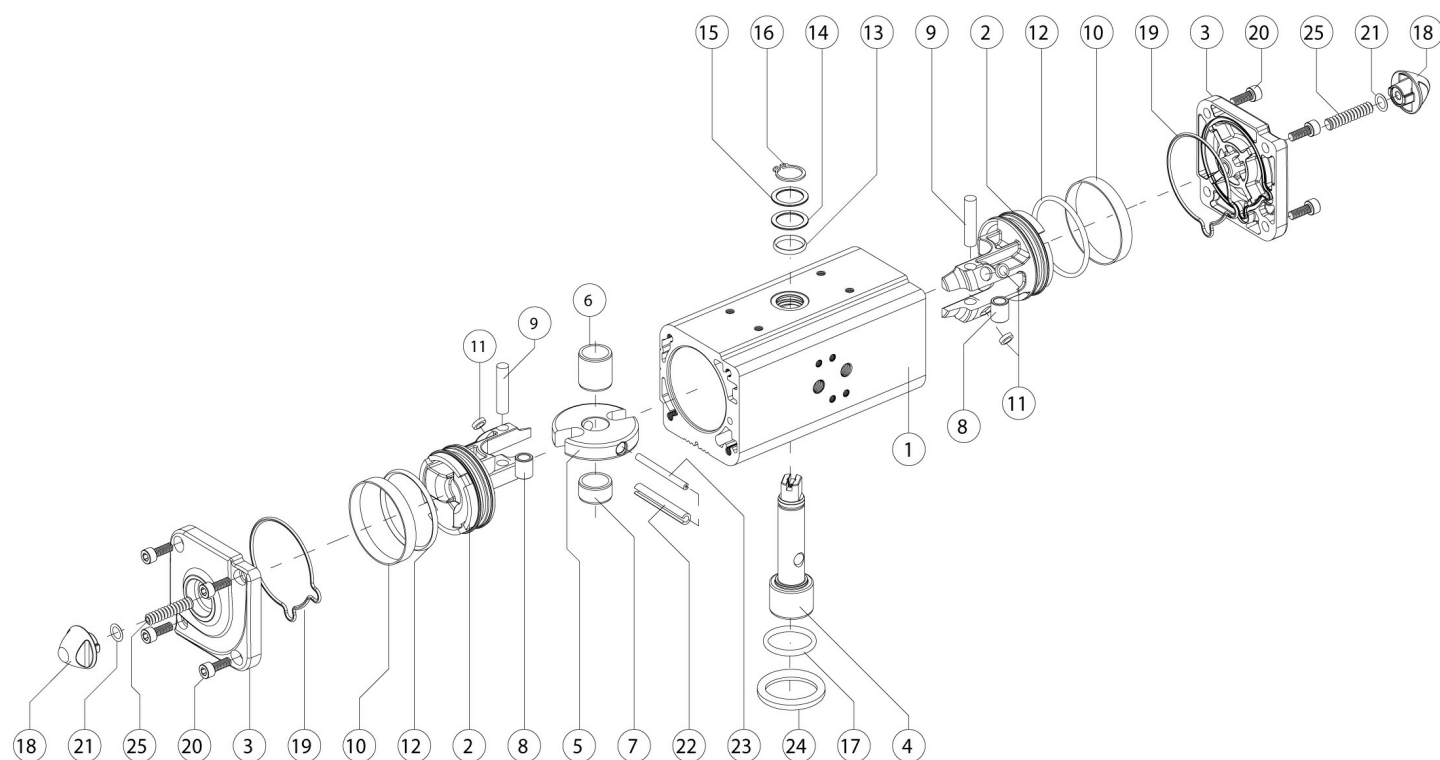

**MATERIALS SPECIFICATION**

Pos	Denomination	Q.ty	Material
1	Cylinder	1	Aluminium alloy
2	Piston	2	Aluminium alloy
3	Cap	2	Aluminium alloy
4	Shaft	1	Stainless steel

5	Scotch yoke	1	Steel alloy
6	Support bush	1	Acetalic resin
7	Shaft support	1	Acetalic resin
8	Bush	2	Steel alloy
9	Rotative sleeve	2	Steel alloy
10*	Dynamic seal	2	Polyurethan
11*	Piston's suport	4	PTFE caric carbo-grafite
12*	O-ring	2	Nitrilic rubber
13*	O-ring (upper sealing shaft)	1	FKM
14*	External support ring	1	Acetalic resins
15	Washer	1	Stainless steel
16	Seeger	1	Stainless steel
17*	O-ring (low sealing shaft)	1	FKM
18	Nut	2	Aluminium alloy
19*	Tappo o-ring	2	Nitrilic rubber
20	Screws	8	Stainless steel
21	O-ring	2	Nitrilic rubber
22	External elastic pin of the yoke	1	Steel alloy
23	Internal elastic pin of the yoke	1	Steel alloy
24	Centering ring	1	Aluminium alloy
25	Stroke adjustment screw	2	Stainless steel

\*Components of spare part kit

# Codes, dimensions and materials - DA2880

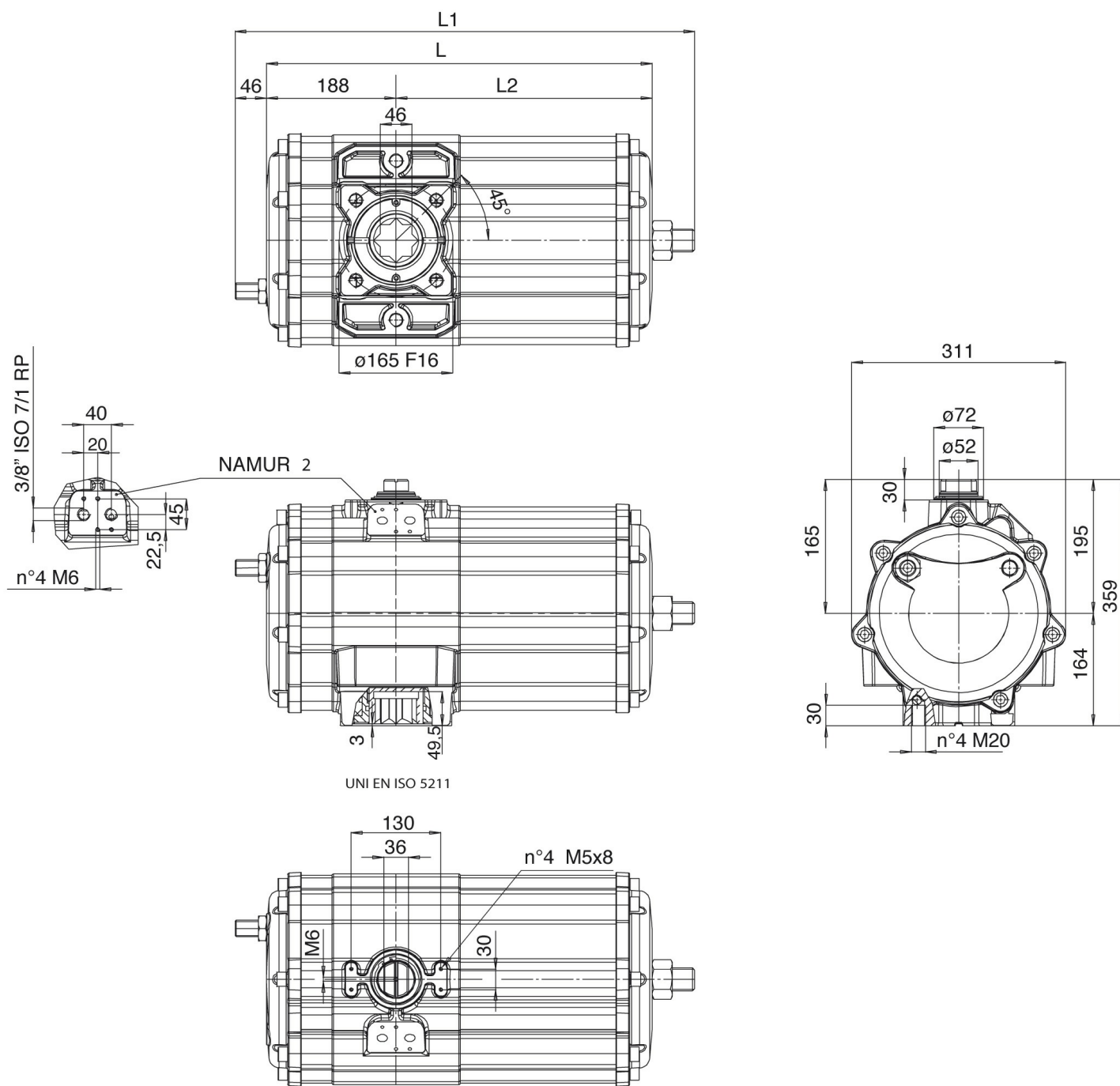

Interfaccia per accessori secondo *Interface for accessories according to* VDI/VDE 3845, EN 15714-3

## DIMENSION TABLE

dimension	L	L1	L2	Weight
double acting <b>DA2880E16D0A</b>	560	667	372	45
air volume dm <sup>3</sup> /cycle	20			
Spare seals	KGD11035			

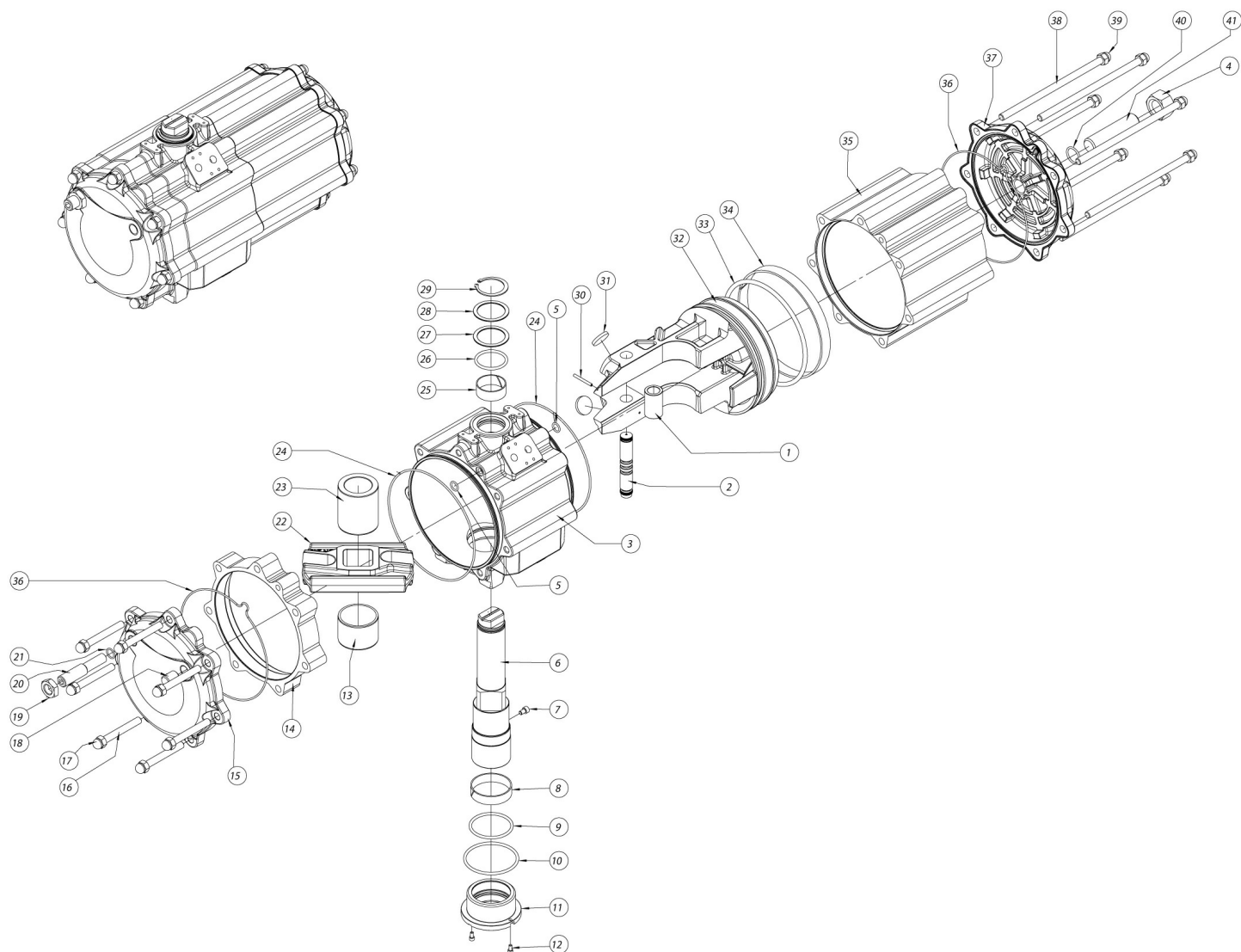

## MATERIALS SPECIFICATION

Pos	Denomination	Q.ty	Material
1	Steel bush	1	Steel alloy
2	Steel pin	1	Steel alloy
3	Body	1	Aluminium
4	Nut	1	Steel alloy
5*	O-ring	2	NBR
6	Shaft	1	Steel alloy
7	Screw	1	Steel alloy
8*	Bearing (shaft bottom)	1	Acetalic resins
9*	O-ring	1	FKM
10*	O-ring	1	FKM
11	Low bearing bush	1	Aluminium
12	Screw	2	Steel alloy
13	Bearing shaft	1	Acetalic resins
14	Spacer	1	Aluminium
15	Cap	1	Aluminium
16	Cap screw	7	Steel alloy

17	Cap nut	7	Steel alloy
18	Grub screw	1	Steel alloy
19	Nut	1	Steel alloy
20	Grub screw	1	Steel alloy
21*	O-ring	1	NBR
22	Scotch yoke	1	Steel alloy
23	Bearing shaft	1	Acetalic resin
24*	O-ring	2	NBR
25*	Bearing (shaft top)	1	Acetalic resin
26*	O-ring	1	FKM
27*	Trusth bearing	1	Acetalic resin
28	Washer	1	Steel alloy
29	Seeger	1	Steel alloy
30	Spring pin	1	Steel alloy
31*	Bearing (piston back)	2	Acetalic resin
32	Piston	1	Aluminium
33*	O-ring	1	NBR
34*	Bearing (piston head)	1	Acetalic resin
35	Lateral cylinder	1	Aluminium
36*	O-ring	2	NBR
37	Cap	1	Aluminium
38	Cap screw	7	Steel alloy
39	Cap nut	7	Steel alloy
40*	O-ring	1	NBR
41	Grub screw	1	Steel alloy

\*Components of spare part kit

# Codes, dimensions and materials - DA3840

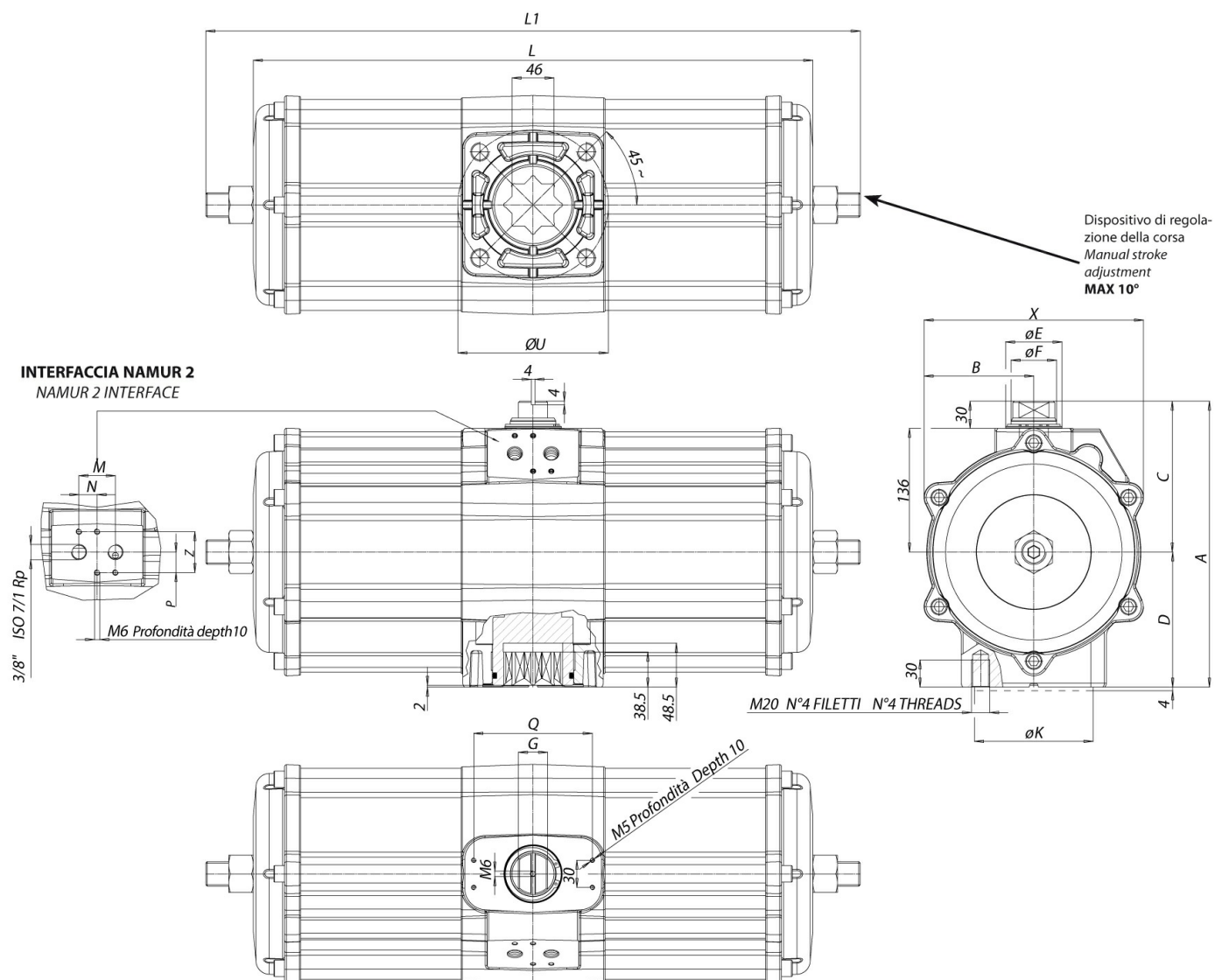

## DIMENSION TABLE

dimension mm	A	b	c	d	$\varnothing e$	$\varnothing f$	g	$\varnothing k$	l	l1	m	n	p	q	$\varnothing u$	x	z	Weight
<b>DA3840E1600A</b>	314,5	120,4	166	148,5	62	50	32	130	614	718	40	20	22,5	130	165	241	45	49 kg
air volume dm <sup>3</sup> /cycle	23,09																	
Spare seals	KGDI0030																	



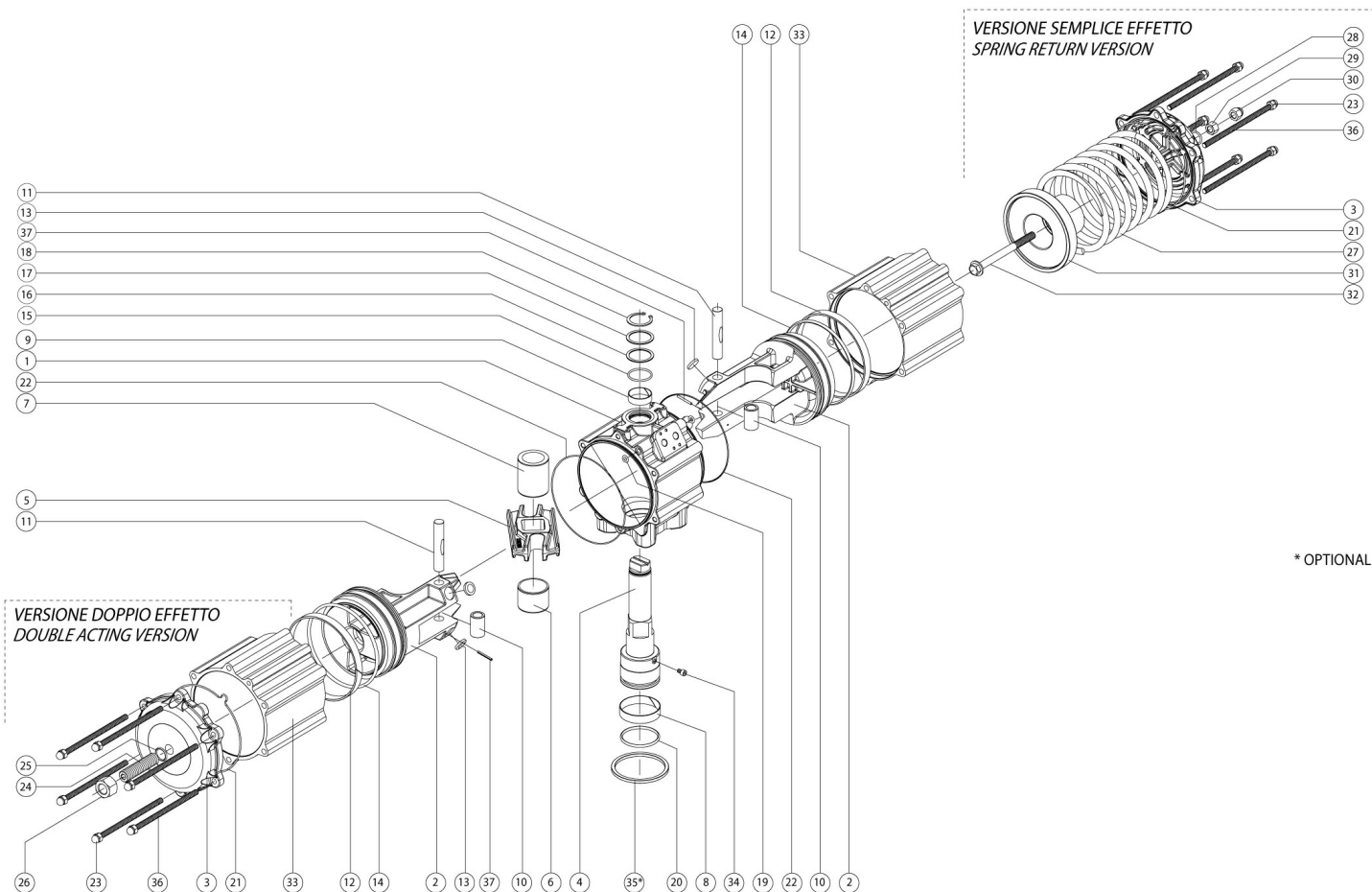

### MATERIALS SPECIFICATION

Pos	Denomination	Q.ty	Material
1	Cylinder	1	Aluminium alloy
2	Piston	2	Aluminium alloy
3	Cap	2	Aluminium alloy
4	Shaft	1	Stainless steel
5	Scotch yoke	1	Steel alloy
6	Bearing shaft	1	Acetalic resins
7	Bearing shaft	1	Acetalic resins
8*	Bearing (shaft bottom)	1	Acetalic resins
9*	Bearing (shaft top)	1	Acetalic resins
10	Steel bush	2	Steel alloy
11	Steel pin	2	Lega acciaio
12*	Bearing (piston head)	2	Acetalic resins
13*	Bearing (piston back)	4	Acetalic resins
14*	O-ring	2	NBR
15*	O-ring	1	FKM
16*	Thrust bearing	1	Acetalic resins
17	Washer	1	Stainless steel
18	Seeger	1	Stainless steel
19*	O-ring	2	NBR
20*	O-ring	1	FKM

21*	O-ring	2	NBR
22*	O-ring	2	NBR
23	Cap nut	12	Stainless steel
24	Grub screws	2	Stainless steel
25*	O-ring	2	NBR
26	Nut	2	Stainless steel
27	Spring	4	Steel alloy
28*	O-ring	2	NBR
29	Nut	2	Stainless steel
30	Cap nut	2	Stainless steel
31	Spring cap	2	Aluminium alloy
32	Screw	2	Stainless steel
33	Cylinder	2	Aluminium alloy
34	Screw	1	Stainless steel
35	Center ring	1	Aluminium alloy
36	Cap screw	12	Steel alloy
37	Spring pin	2	Steel alloy

\*Components of spare part kit

# Codes, dimensions and materials - DA5760

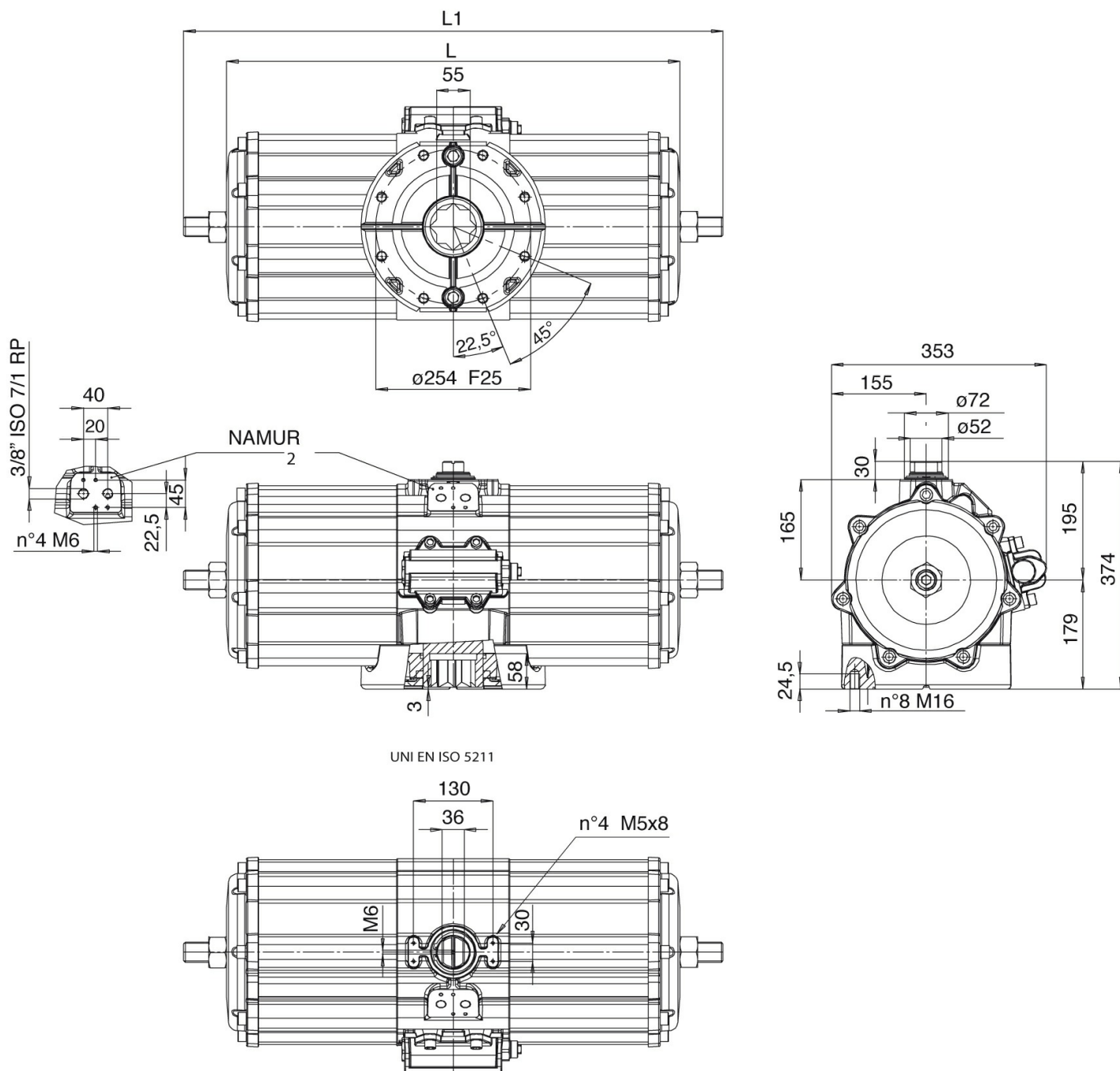

Interfaccia per accessori secondo *Interface for accessories according to* **VDI/VDE 3845, EN 15714-3**

## DIMENSION TABLE

dimension	double acting <b>DA5760E25D0A</b>
<b>L mm</b>	<b>744</b>
<b>L1 mm</b>	<b>885</b>
<b>Weight Kg</b>	<b>80</b>
air volume dm <sup>3</sup> /cycle	<b>38</b>
Spare seals	<b>KGDI2035</b>

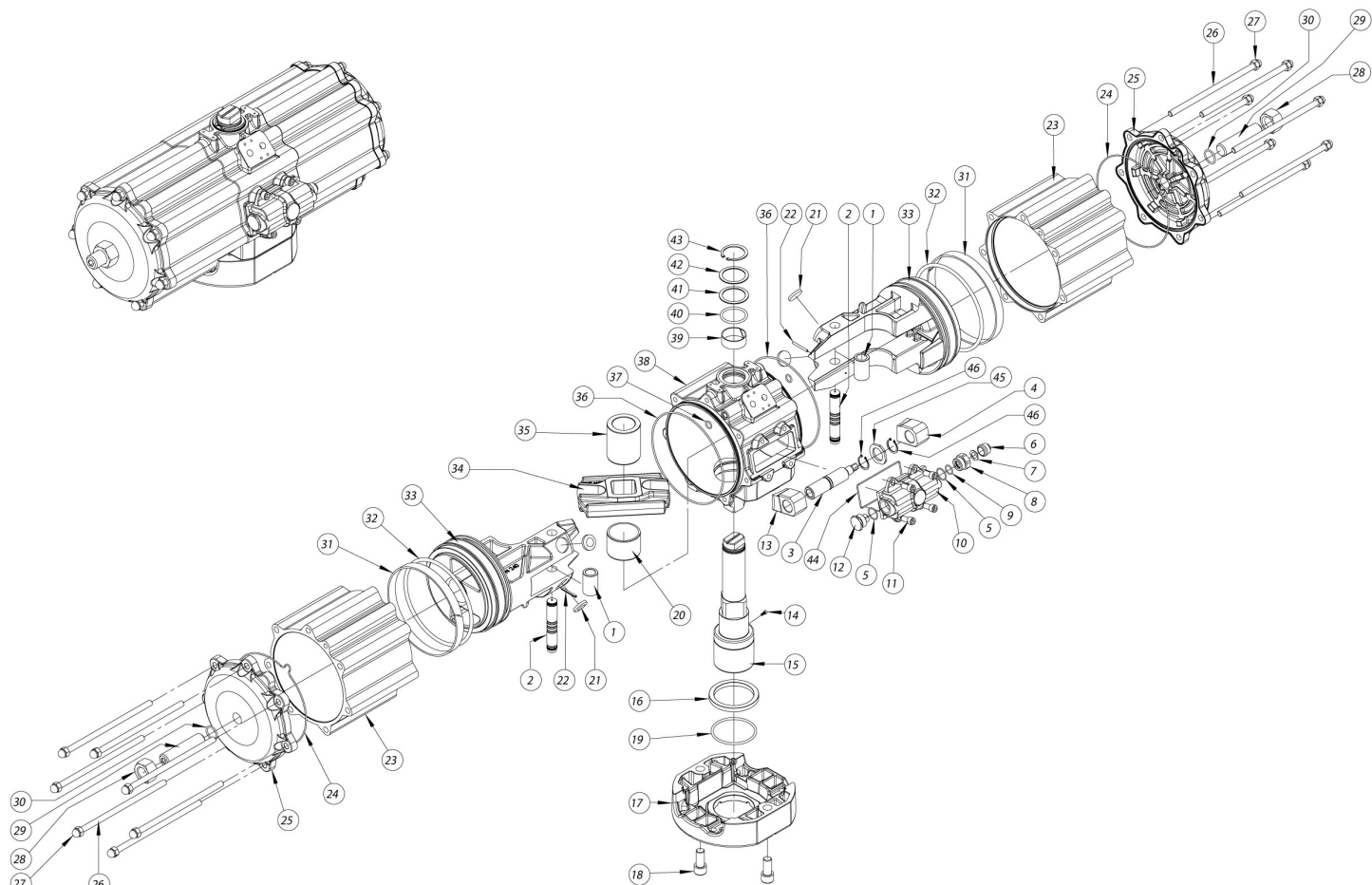

### MATERIALS SPECIFICATION

Pos	Denomination	Q.TA'	Material
1	Steel bush	2	Steel alloy
2	Steel pin	2	Steel alloy
3	Regolation screw	1	Steel alloy
4	Left stop	1	Steel alloy
5*	O-ring	2	NBR
6	Pretection cap	1	Aluminium
7	Antirotation washer	1	Steel alloy
8	Metal ring	1	Stainless steel
9*	O-ring	1	NBR
10	Carter	1	Aluminium
11	Screw	4	Steel alloy
12	Metal ring	1	Stainless steel
13	Right stop	1	Steel alloy
14	Screw	1	Steel alloy
15	Shaft	1	Steel alloy
16	Bearing (shaft bottom)	1	Acetalic resins
17	Interface F25	1	Aluminium
18	Screw	2	Steel alloy
19*	O-ring	1	FKM

20	Bearing shaft	1	Acetalic resins
21*	Bearing (piston back)	4	Acetalic resins
22	Spring pin	2	Steel alloy
23	Lateral cylinder	2	Aluminium
24*	O-ring	2	NBR
25	Cap	2	Aluminium
26	Cap screws	14	Steel alloy
27	Cap nut	14	Steel alloy
28	Nut	2	Steel alloy
29	Grub screws	2	Steel alloy
30*	O-ring	2	NBR
31*	Bearing (piston head)	2	Acetalic resin
32*	O-ring	2	NBR
33	Piston	2	Aluminium
34	Scotch yoke	1	Steel alloy
35	Bearing shaft	1	Acetalic resin
36*	O-ring	2	NBR
37*	O-ring	2	NBR
38	Body	1	Aluminium
39*	Bearing (shaft top)	1	Acetalic resin
40*	O-ring	1	FKM
41*	Thrust bearing	1	acetalic resin
42	Washer	1	Steel alloy
43	Seeger	1	Steel alloy
44*	Gasket	1	NBR
45	Washer	1	Steel alloy
46	Seeger	2	Steel alloy

\*Components of spare part kit

# Codes, dimensions and materials - DA8000

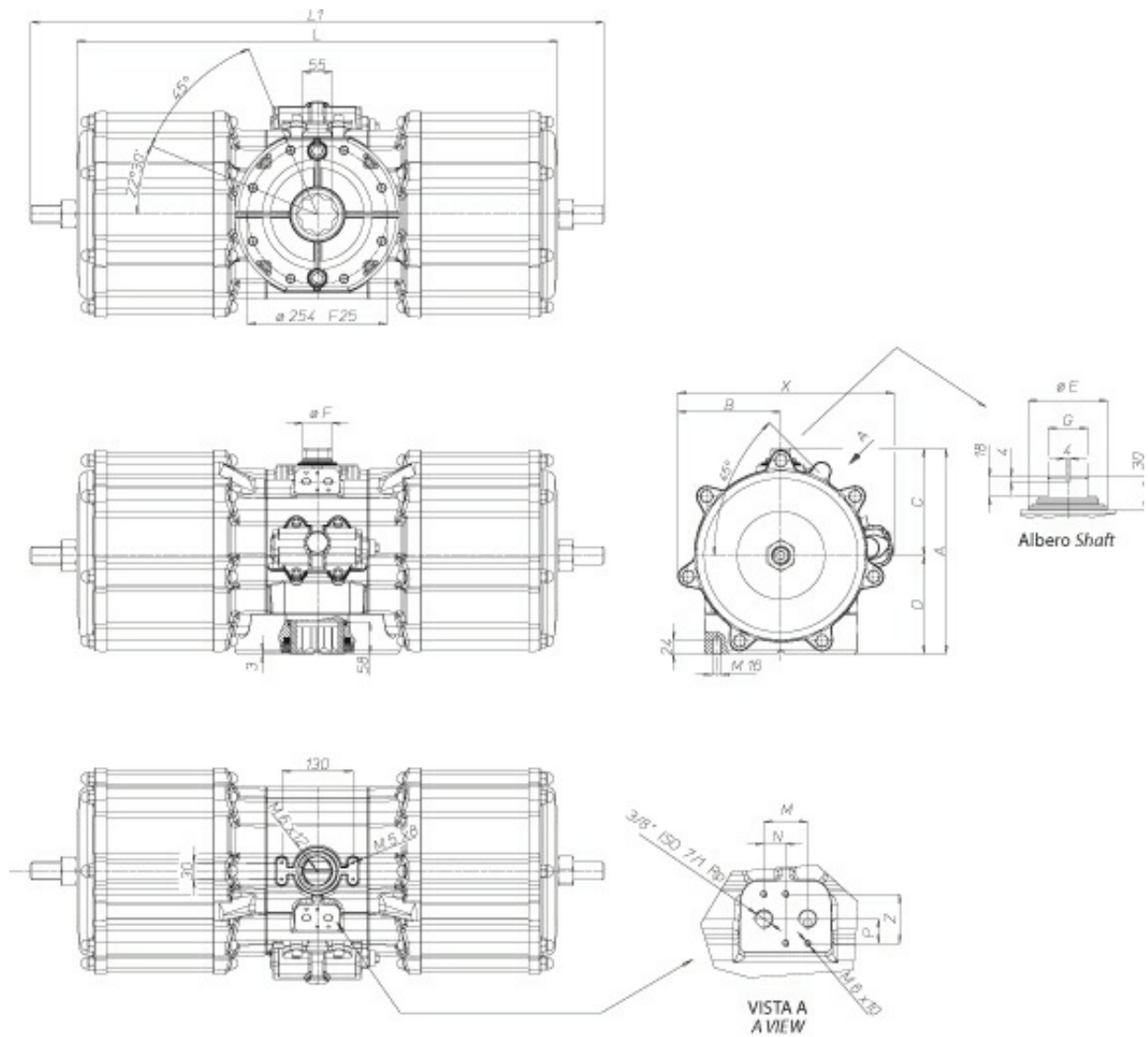

## DIMENSION TABLE

dimension mm	A	b	c	d	$\varnothing e$	$\varnothing f$	g	m	n	l	l1	p	x	z	Weight
<b>DA8000E25D0A</b>	374	188	195	179	72	52	36	40	20	877	1044	22,5	394	45	110 Kg
air volume dm <sup>3</sup> /cycle	65														
Spare seals	KGD11040														

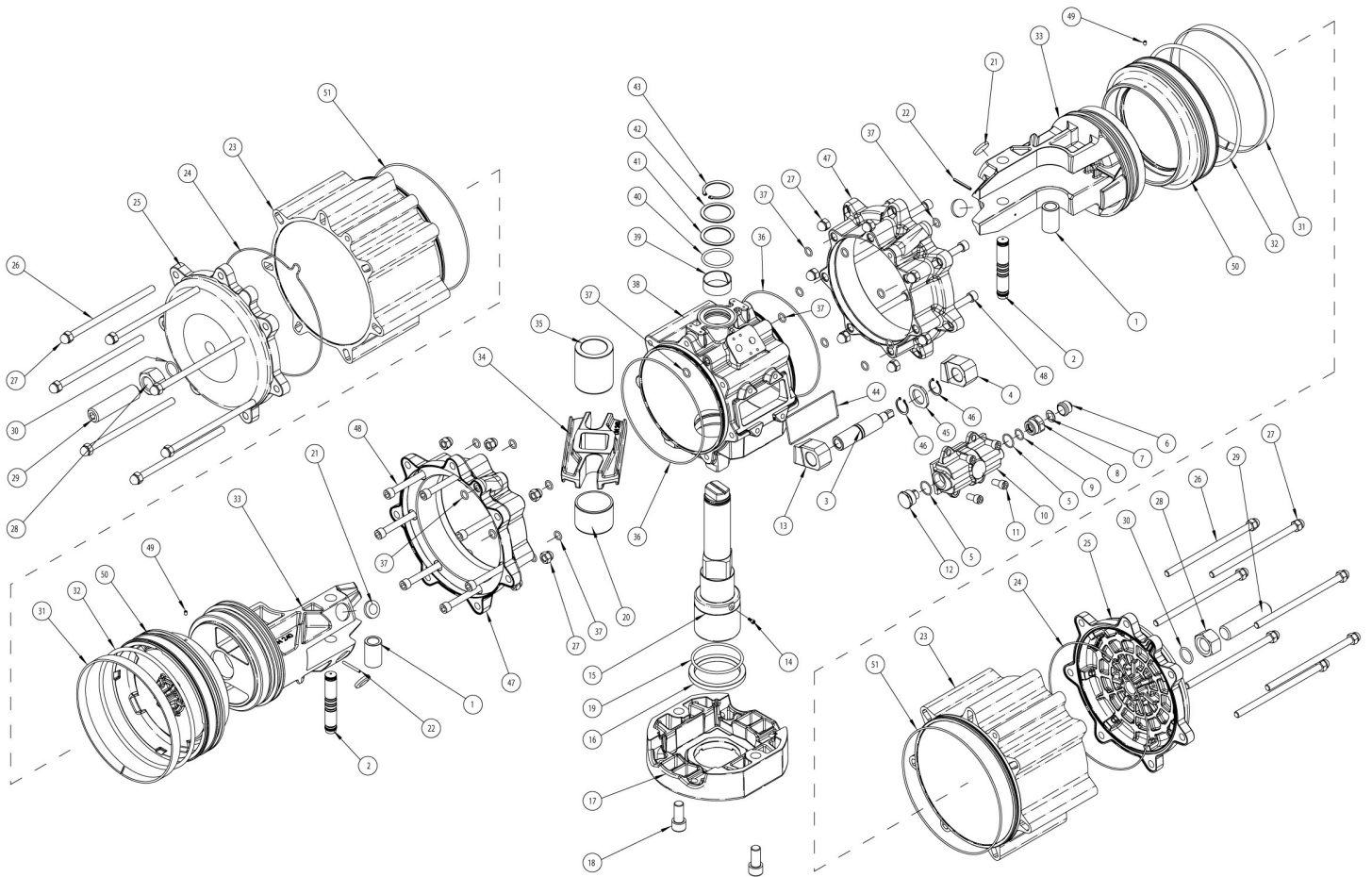

## MATERIALS SPECIFICATION

Pos	Denomination	Q.TA'	Material
1	Steel bush	2	Steel alloy
2	Steel pin	2	Steel alloy
3	Regulation screw	1	Steel alloy
4	Left stop	1	Steel alloy
5*	O-ring	2	NBR
6	Protection cap	1	Aluminium
7	Antirotation washer	1	Steel alloy
8	Metal ring	1	Stainless steel
9*	O-ring	1	NBR
10	Carter	1	Aluminium
11	Screw	4	Steel alloy
12	Metal ring	1	Stainless steel
13	Right stop	1	Steel alloy
14	Screw	1	Steel alloy
15	Shaft	1	Steel alloy
16	Bearing (shaft bottom)	1	Acetalic resins
17	Interface F25	1	Aluminium
18	Screw	2	Steel alloy
19*	O-ring	1	FKM
20	Bearing shaft	1	Acetalic resins

21	Bearing (piston back)	4	Acetalic resins
22	Spring pin	2	Acciaio Steel alloy
23	Lateral cylinder	2	Aluminium
24*	O-ring	2	NBR
25	Cap	2	Aluminium
26	Cap screws	14	Steel alloy
27	Cap nut	28	Steel alloy
28	Nut	2	Steel alloy
29	Grub screws	2	Steel alloy
30*	O-ring	2	NBR
31*	Bearing (piston head)	2	Acetalic resins
32*	O-ring	2	NBR
33	Piston	2	Aluminium
34	Scotch yoke	1	Steel alloy
35	Bearing shaft	1	Acetalic resins
36*	O-ring	2	NBR
37*	O-ring	18	NBR
38	Body	1	Aluminium
39*	Bearing (shaft top)	1	Acetalic resins
40*	O-ring	1	FKM
41*	Thrust bearing	1	Resina acetatica
42	Washer	1	Steel alloy
43	Seeger	1	Steel alloy
44*	Gasket	1	NBR
45	Washer	1	Steel alloy
46	Seeger	2	Steel alloy
47	Flange	2	Aluminium
48	Screws	14	Steel alloy
49	Grub screw	2	Steel alloy
50	Flange	2	Aluminium
51*	O-ring	2	NBR

\*Components of spare part kit