

## Power Amplifiers with PID Modules

### EEA-PAM-5\*\*-D-32 Series

#### General Description

The EEA-PAM-5\*\*-D-32 Eurocards are power amplifiers with integrated PID modules. Each of these cards replaces two conventional electronic cards.

#### Features and Benefits

- Includes all features of "A" amplifiers (except gain)
- User configurable PID feed-forward, closed-loop operation
- Command input ramps
- Analog feedback sensor interface
- Automatic switch-over p/Q function
- Built-in test feature
- The design reduces the amount of external wiring, saves space in the rack enclosure and requires only one 24V supply
- The general purpose, integrated module can be configured using DIL switches (D1-D9) and potentiometers for the following applications:
  - Closed-loop pressure control using either proportional pressure valves or servo-performance proportional valves
  - Closed-loop velocity control
  - Closed-loop position control
  - p/Q control with internal or external switch-over from Q to p
- The DIL- switch and potentiometer settings can easily be reconfigured on different cards

#### Front Panel

##### LEDs

- [1] 24V power supply input, green
- [2] 15V control supply output, green
- [3] Drive (solenoid) enabled, yellow
- [4] Overload, red
- [5] LVDT failure, red ●
- [6] Drive level to solenoid, yellow

##### Potentiometers

- [7] Deadband compensation, flow P to B ▲ ◆
- [8] Deadband compensation, flow P to A ▲ ◆

##### LED

- [9] Ramps enabled, yellow

##### Potentiometers

- [10] Command ramp up
- [11] Command ramp down

##### Monitor points ■

- [12] MP1: Conditioned command signal
- [13] Common ground (0V)
- [14] MP2: LVDT (spool) position ▼

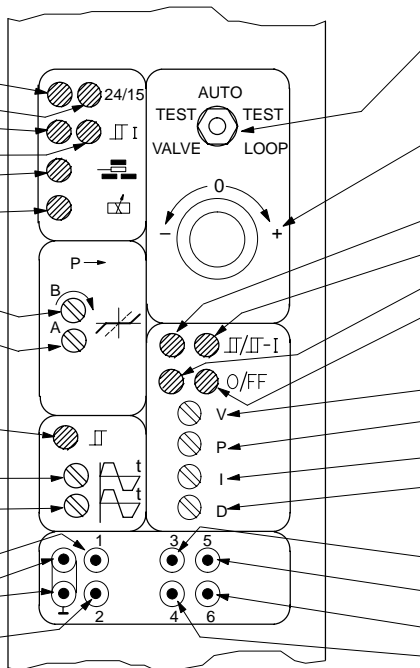

- [15] Mode switch
  - TEST VALVE setting
  - AUTO function setting
  - TEST LOOP setting

- [16] Test potentiometer

##### LEDs

- [17] PID-controller enabled, yellow
- [18] Integrator enabled, yellow
- [19] Feedback = command signal, green
- [20] Sensor failure, red

##### Potentiometers

- [21] Feed-forward signal scaling
- [22] P-gain
- [23] I-gain
- [24] D-gain

##### Monitor points ■

- [25] MP3: Command signal
- [26] MP5: PID-controller output
- [27] MP6: Integrator output
- [28] MP4: Feedback signal

▲ Number and function of potentiometers [7], [8], [7.2] vary according to model type as follows: [7.2] Offset  
**For models -513/541/553-**

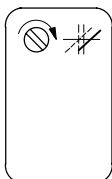

- LED and symbol not on EEA-PAM-513/523/525 amplifiers.
- ▼ Solenoid current for EEA-PAM-523/525-D models.
- ◆ Ø2,0 mm (0.0787" dia.) sockets.
- ◆ In the case of EEA-PAM-523/525-D models one of these relationships may not apply if two single solenoid valves are connected.



This product has been designed and tested to meet specific standards outlined in the European Electromagnetic Compatibility Directive (EMC) 89/336/EEC, amended by 91/263/EEC, 92/31/EEC and 93/68/EEC, article 5. For instructions on installation requirements to achieve effective protection levels, see this leaflet and the Installation Wiring Practices for Vickers Electronic Products leaflet 2468. Wiring practices relevant to this Directive are indicated by Electromagnetic Compatibility (EMC).

# Model Codes

Amplifier model	For valves
EEA-PAM-513-D-32	KCG-3, KCG-6/8
EEA-PAM-523-D-32	KX(C)G-6/8
EEA-PAM-525-D-32	K*G4V-3, KDG5V-5/7/8
EEA-PAM-533-D-32	K*G4V-5
EEA-PAM-535-D-32	KF*G4V-3
EEA-PAM-541-D-32	KF*G4V-5
EEA-PAM-543-D-32	KHDG5V-5/7/8 with zerolapped mainspool
EEA-PAM-553-D-32	KSDG4V-3
EEA-PAM-561-D-32	KFDG5V-5/7
EEA-PAM-568-D-32	KFDG5V-8
EEA-PAM-571-D-32	CVU-**-EFP1
EEA-PAM-581-D-32	KHDG5V-5/7/8

} With type "H"  
coils only

## Operating Data

Power (input) supply	bz32	See appropriate base amplifier, e.g. for EEA-PAM-535-D-32 see EEA-PAM-535-A-32
Control (output) supplies	z22	+15V for LVDTs only
Reference voltages	z2	+10V x 5 mA
	b2	-10V x 5 mA
Analog inputs:		
Command inputs		
Direct-voltage inputs	b6, b8, b10, z8	
Inverting-voltage input	z10	
Voltage range		± 10V
Input impedance (voltage)		47 kΩ
Current input	z6	
Current range		± 20 mA
Input impedance (current)		100Ω
Feed-forward input		
Input impedance	d8	6 kΩ
Voltage range		± 10V
Input to ramp generator		
Input impedance	d28	10 kΩ
Voltage range		± 10V
Inputs from sensors		
Voltage input	d2	
Input impedance		1 MΩ
Voltage range		0 to 10V, or ± 10V■
Current input		
Input impedance		100Ω
Current range (See "DIL Switches" five pages on)		4-20 mA or 0-20 mA
Monitoring of sensor failure for sensors with a current outout only		

■ The demand signal should have the same voltage range as the sensor feedback, i.e. 0 to 10V, or ± 10V.



Potentiometers: Feed-forward P-gain (depends on DIL switch D2): I-gain range D-gain range Sensor signal gain range■ Sensor signal offset range■		V = 20% to 100% P = 0,1 to 50V/V K <sub>i</sub> = 0,5 to 100 V/s/V K <sub>d</sub> = 0 to 0,05 V/V/s 90% to 120% ± 10%
Monitor points: Conditioned command signal LVDT (spool) position▲ Command signal Feedback signal PID-controller output Integrator output (100%, independent of D3, D4, D5) Voltage range Monitor point impedance	MP1 MP2 MP3 MP4 MP5 MP6	± 10V 10 kΩ
Ambient conditions: Storage temperature range Operating temperature range		-25 to +85°C (-13 to +185°F) 0 to 50°C (32 to 122°F)
Mass		0,4 kg (0.88 lb) approx.
Installation and start-up guidelines (supplied with product)		9161
Installation wiring requirements for Vickers electronic products		2468
Application notes (available on request)		9056
Supporting products: Power supply unit options Electronic accessories Portable test equipment		See catalogs: 2419 2460 2462 and 2315

■ Located on PID module.

▲ All amplifiers except EEA-PAM-523/525 models, in which solenoid current is monitored.



**Warning:** Electromagnetic Compatibility (EMC)

*It is necessary to ensure that the valve is wired up in accordance with the connection arrangements shown in this leaflet. For effective protection, the user's electrical cabinet, the valve subplate or manifold and the cable screens should be connected to efficient earth (ground) points. The metal 7-pin connector part no. 934939 should be used for the integral amplifier.*

*In all cases, both valve and cable should be kept as far away as possible from any source of electromagnetic radiation such as cables carrying heavy current, relays and certain kinds of portable radio transmitters, etc. Difficult environments could mean that extra screening may be necessary to avoid the interference.*

# Circuit and Connections

EEA-PAM-5\*\*-D-32

Read circuit in conjunction with that for relevant base amplifier EEA-PAM-5\*\*-A

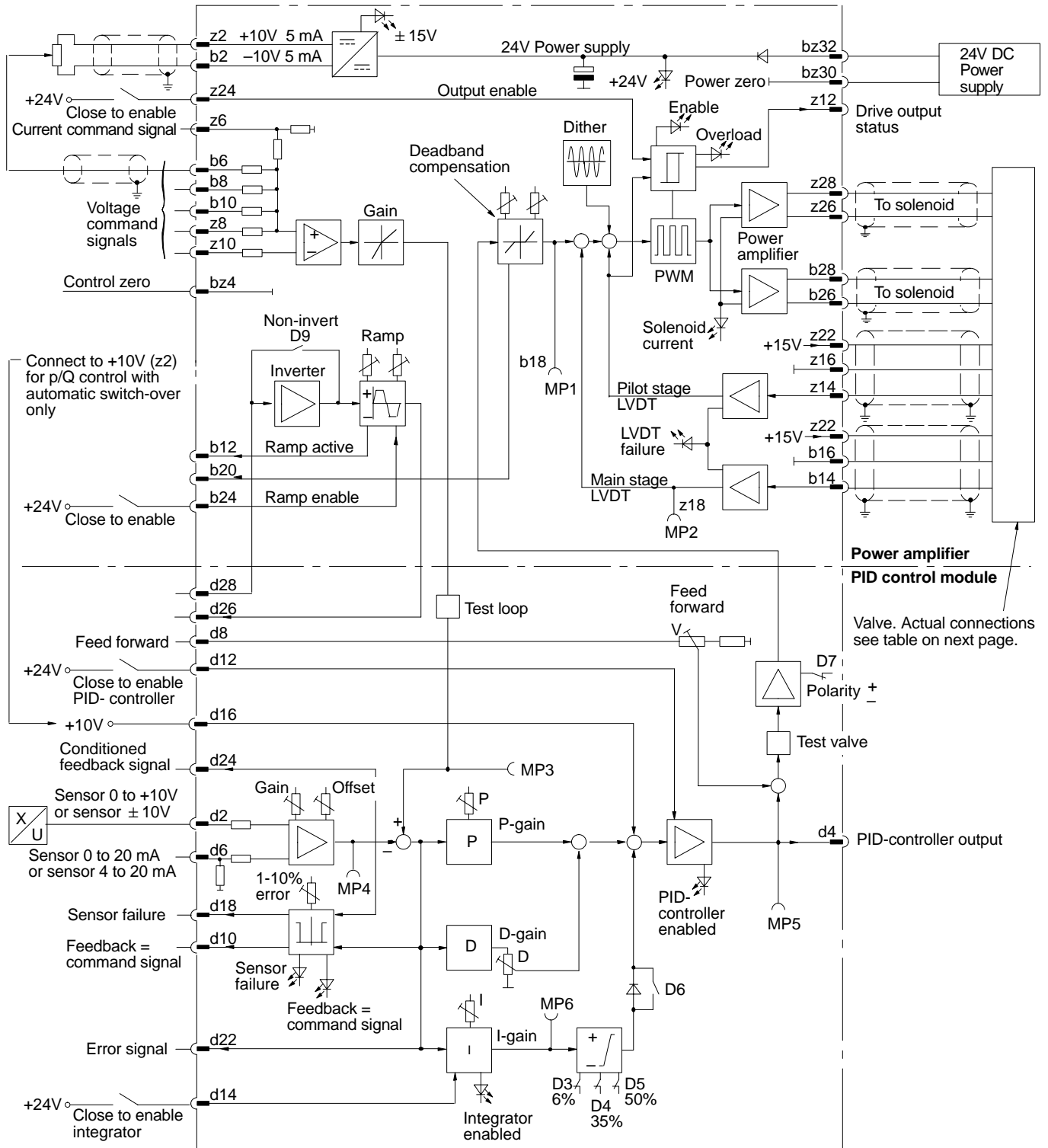

⊥ Customer's protective ground connection.

# Solenoid and LVDT Connections for Proportional Valves

Amplifier type	Solenoid with LVDT and/or for flow P to B	Solenoid without LVDT, or on pilot valve	Pilot-stage LVDT, (black plug):				Main-stage LVDT, (gray plug):			
			Pin 1	Pin 2	Pin 3	Pin 4	Pin 1	Pin 2	Pin 3	Pin 4
EEA-PAM-513-D-32	b26/b28	—	—	—	—	Not connected	—	—	—	Not connected
EEA-PAM-523-D-32	b26/b28	z26/z28	—	—	—	Not connected	—	—	—	Not connected
EEA-PAM-525-D-32	b26/b28	z26/z28	—	—	—	Not connected	—	—	—	Not connected
EEA-PAM-533-D-32	b26/b28	z26/z28	—	—	—	Not connected	b14	z22	b16	Not connected
EEA-PAM-535-D-32	b26/b28	z26/z28	—	—	—	Not connected	b14	z22	b16	Not connected
EEA-PAM-541-D-32	—	z26/z28	z14	z22	z16	Not connected	b14	z22	b16	Not connected
EEA-PAM-553-D-32	—	z26/z28	—	—	—	Not connected	b14	z22	b16	Not connected
EEA-PAM-561-D-32	—	z26/z28	—	—	—	Not connected	b14	z22	b16	Not connected
EEA-PAM-568-D-32	—	z26/z28	—	—	—	Not connected	b14	z22	b16	Not connected
EEA-PAM-571-D-32	—	z26/z28	—	—	—	Not connected	b14	z22	b16	Not connected
EEA-PAM-581-D-32	—	z26/z28	z14	z22	z16	Not connected	b14	z22	b16	Not connected

## Installation Dimensions in mm (inches)

Plug-in Unit of 3U height, to IEC 297

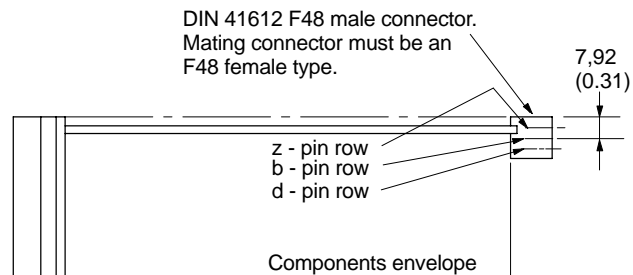
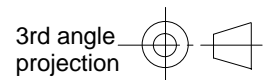

M2,5 x 11 (0.43) long collar screws supplied with panel for fixing

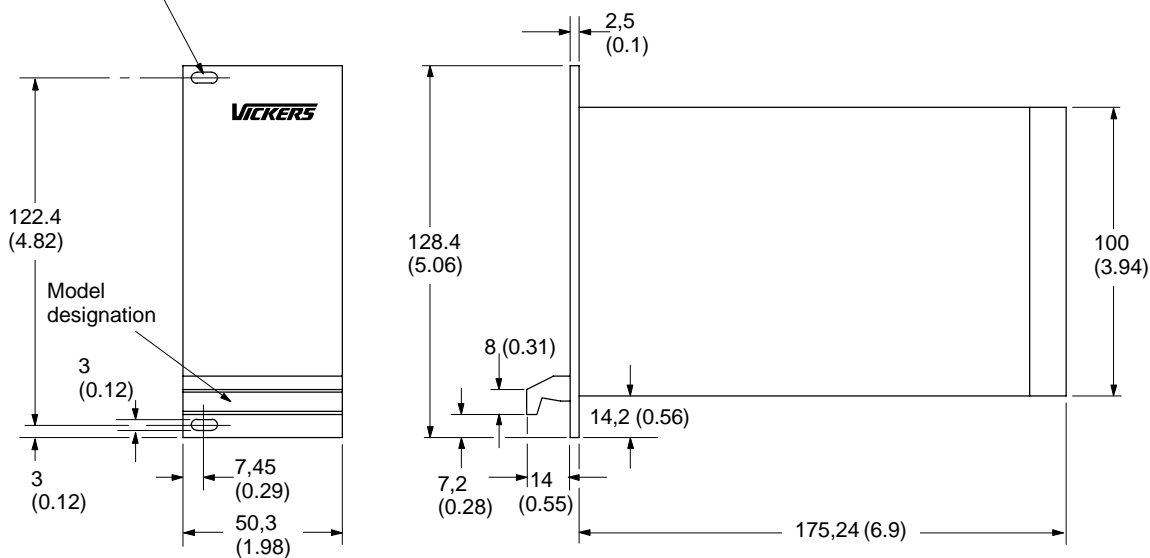

# Application Notes

## DIL Switches

The controller is configured for the application using DIL switches, located on the board.

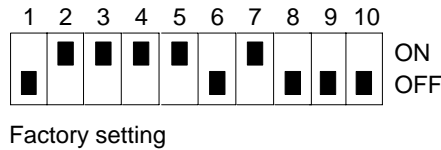

The DIL switch operates as follows:

Switch	ON	OFF
D1:	For sensors with 4 to 20 mA output	For sensors with $\pm 10V$ or 20 mA outputs
D2:	P-gain 2 to 50	P-gain 0,1 to 2
D6:	One-sided limitation of the integrator output. (Only useful for proportional pressure and proportional throttle valves.)	No limitations of integrator output
D7:	Inverts the controller output signal	Non-inverted signal
D8:	For sensors with 4 to 20 mA output	For sensors with $\pm 10V$ or 20 mA outputs
D9:	Ramp signal not inverted	Ramp signal inverted
D10:	Not used	—

For p/Q control with automatic switch-over, connect d16 to z2 (+10V). The flow command signal (Q) is applied to the feed-forward input, d8, and the desired pressure setpoint voltage applied to a command signal input (b6/8/10 or z6/8/10). The pressure feedback sensor is connected to the sensor input d2, or d6 as required.

The pressure control loop will override the flow command to limit the pressure to the level determined by the pressure setpoint voltage. Adjust P, I and D gains for best performance.

The switches D3, D4 and D5 belong together. They limit the I output volts between 100% (10V) and 5% (0,5V) as follows:

D3	D4	D5	I-limit
ON	ON	ON	100%
ON	ON	OFF	50%
ON	OFF	ON	35%
ON	OFF	OFF	25%
OFF	ON	ON	5,9%
OFF	ON	OFF	5,8%
OFF	OFF	ON	5,3%
OFF	OFF	OFF	5,0%

## Reconfiguration of Controller Parameters

Once the controller parameters have been optimized and set, they can be measured by means of an ohmmeter. This allows easy reconfiguration of the controller on different cards for use as spare parts or on standard machine series.

Four test points are located on the PID-module for this purpose, see diagram for locations. The resistance between the appropriate test point and ground (at the front panel monitor point) determines the controller parameters:

- P = P-gain
- I = I-gain
- D = D-gain
- V = Feed-forward gain

## Location of User Features on PID Module

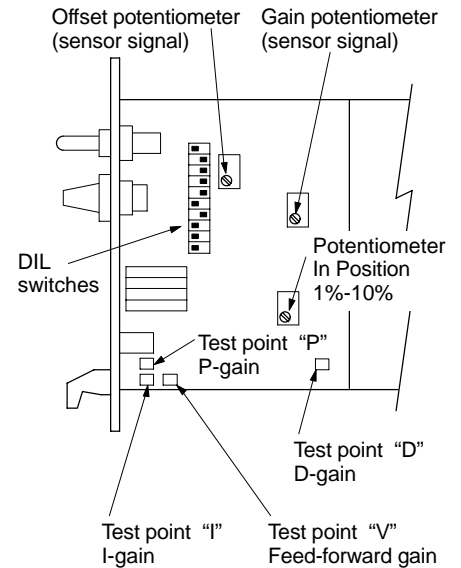

### Operation of the Integrated Test Mode

The basic operation of the hydraulic actuator can be tested by using the 3-position mode switch mounted on the front panel. To select different modes the toggle switch must be lifted slightly before turning it to a new position.

#### Caution:

Before setting the mode switch to either "Test valve" or "Test loop" make sure the test potentiometer is set to "0". Otherwise sudden movements of the actuator may occur.

The mode switch has three positions:

#### AUTO

The controller operates in closed-loop mode, using the external command signal. The test potentiometer is disconnected.

#### TEST VALVE

An open-loop command signal for the valve comes directly from the potentiometer. The external input signal is disconnected. The hydraulic part of the system may be tested in this configuration.

#### TEST LOOP

The closed-loop command signal for the PID-controller comes directly from the potentiometer. The external signal input is disconnected. This configuration allows for verification of the valve polarity and the control parameters.

