



# WESTCAR s.r.l.

## ROTOFLUID

ENGLISH

# FLUID COUPLINGS





# WESTCAR PRODUCTS

ROTOFLUID hydraulic couplings for rated power up to 4000 kW



ROTOGEAR tooth gear couplings for torques up to 383.000 Nm

ROTOFLUID GGG hydraulic couplings (with cast-iron casing) for rated power from 100 to 6000 kW



ROTOFLEXI® flexible couplings with quick replacement of the rubber element without axial hubs movement. For torques up to 4.000 Nm.

ROTOFLUID-SCF/DCF hydraulic couplings with simple/double delay chamber

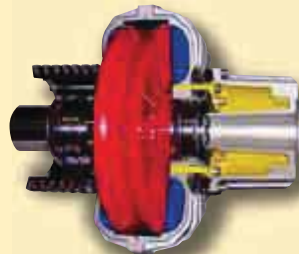

HBX – GCX – HPX disc couplings. With spacer HBSX – GCSX – HPSX - BE. Torques up to 1.043.300 Nm

ROTOFLUID-CA hydraulic couplings with annular chamber and starting torque lower than nominal motor torque

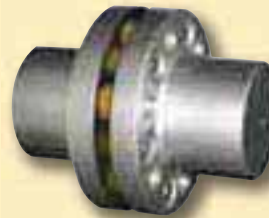

ROTOPIN flexible couplings with pins and buffers axially sliding. For torques up to 300.000 Nm

Drum and disc brakes with brake servo

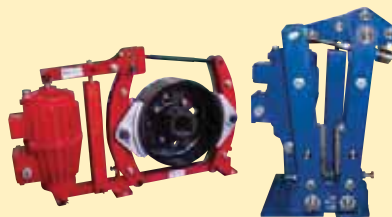

ROTOGRID flexible taper grid couplings. For torques up to 169.500 Nm

**SOFTSTART**  
Static starter with digital control for rated power up to 750 kW.  
Energy saving function.  
Water hammering control.  
Programming also via RS 485



ROTOMECH hydromechanical couplings with hydraulic start-up and centrifugal mechanical lock-up with zero slip at running. For rated power up to 1500 kW



A RICHIESTA SI POSSONO FORNIRE I PRODOTTI CERTIFICATI ATEX.

<b>TABLE OF CONTENTS</b> .....	<b>PAGE</b>
Operating principles and features of ROTOFLUID couplings .....	2
Electric motor characteristic curves with and without fluid coupling .....	3
Fluid couplings with delay chamber .....	4
Characteristic starting curves .....	5
ROTOFLUID coupling selection diagram .....	6
ROTOFLUID coupling selection table for 50 Hz, 60 Hz UNEL MEC electric motors .....	7
Performance calculation .....	8-9
ROTOFLUID couplings moments of inertia .....	10
<b>ROTOFLUID ALFA - coupling for in line versions</b> .....	<b>11</b>
Installation options .....	12
ROTOFLUID selection with recommended flexible coupling for standard electric motors .....	13
Table ROTOFLUID ALFA "K" .....	14
Table ROTOFLUID ALFA "SCF K" .....	15
Table ROTOFLUID ALFA "DCF K" .....	16
Table ROTOFLUID ALFA "K-S" "SCF K-S" "DCF K-S" .....	17
Table ROTOFLUID ALFA "K-LRV" "SCF K-LRV" "DCF K-LRV" .....	18
Table ROTOFLUID ALFA "K-LRU" "SCF K-LRU" "DCF K-LRU" .....	19
Table ROTOFLUID ALFA "K-FRV" "SCF K-FRV" "DCF K-FRV" .....	20
Table ROTOFLUID ALFA "K-FRU" "SCF K-FRU" "DCF K-FRU" .....	21
Table ROTOFLUID ALFA "K-AB" "SCF K-AB" "DCF K-AB" .....	22
Table ROTOFLUID ALFA "K-FRD" "SCF K-FRD" "DCF K-FRD" .....	23
Table ROTOFLUID ALFA "K-AFF" "SCF K-AFF" "DCF K-AFF" .....	24
Table ROTOFLUID ALFA "K-FR-PAV" "SCF K-PAV" "DCF K-PAV" .....	25
Table ROTOFLUID ALFA "KK" "SCF KK" "DCF KK" .....	26-27
Brake drum "FP" for ROTOFLUID ALFA "KK" .....	28-29
Table ROTOFLUID ALFA "WAG" "SCF WAG" "DCF WAG" .....	30
Table ROTOFLUID ALFA "WAG-G" "SCF WAG-G" "DCF WAG-G" .....	31
Table ROTOFLUID ALFA "CK-LRS" .....	32
ROTOFLUID coupling ALFA "K-SS" .....	33
<b>ROTOFLUID BETA - coupling for pulley versions</b> .....	<b>34</b>
Mounting examples with ROTOFLUID couplings BETA pulley versions .....	35
Table ROTOFLUID BETA "X" .....	36-37
Table ROTOFLUID BETA "J" .....	38-39
Table ROTOFLUID BETA "H" .....	40
Table ROTOFLUID BETA "Z"-"ZI" .....	41
Bore dimensions table for ROTOFLUID coupling .....	42
Bore dimensions for flexible coupling and brake drum hubs .....	43
ROTOFLUID coupling instructions for replacement and variation of the oil quantity .....	44
ROTOFLUID coupling scf / dcf instructions for replacement and variation of the oil quantity ..	45
Fusible Plug .....	46
Thermal trip plug .....	47
Electric - thermal - switch equipment type "ET" .....	48
Electronic "scd" device for overload control .....	49
Instructions for mounting rotofluid coupling on the motor shaft .....	50
Instructions for pulling off rotofluid coupling from the motor shaft .....	51
Screw puller "VE" type - pulling off system "SE" type .....	51
ROTOFLUID couplings outline and main components .....	52
Recommended spare parts .....	53
Optional functions .....	54
Application requirements .....	55
Fields of application .....	56

**INDEX OF TECH SHEETS**

10-137A** .....	2
10-002B** .....	7
10-013A** .....	44
10-016A** .....	45
10-019D** .....	42
10-023A** .....	43
10-030A** .....	8
10-031A** .....	9
10-035A** .....	10
10-040A** .....	13
10-047A** .....	34
10-052A** .....	56
10-057B** .....	11
10-059A** .....	55
10-060A** .....	54
10-061A** .....	3
10-080A** .....	5
10-100A** .....	6
10-138A** .....	12
10-141A** .....	4
10-142A** .....	35
40-010B** .....	14
40-050A** .....	33
40-280A** .....	32
45-042B** .....	18
45-020B** .....	17
45-043B** .....	19
45-060B** .....	20
45-062A** .....	21
45-066B** .....	25
45-070B** .....	23
45-081B** .....	22
45-082B** .....	26
45-083B** .....	27
45-092B** .....	24
45-112B** .....	30
45-113D** .....	31
45-204A** .....	41
45-210A** .....	38
45-211C** .....	39
45-220A** .....	40
45-250A** .....	36
45-251B** .....	37
50-010B** .....	16
52-006B** .....	15
70-006B** .....	28
70-007B** .....	29
80-002A** .....	46
80-003A** .....	47
80-004A** .....	48
80-022A** .....	49
90-004A** .....	50
90-005A** .....	51
90-018A** .....	52
90-022A** .....	53

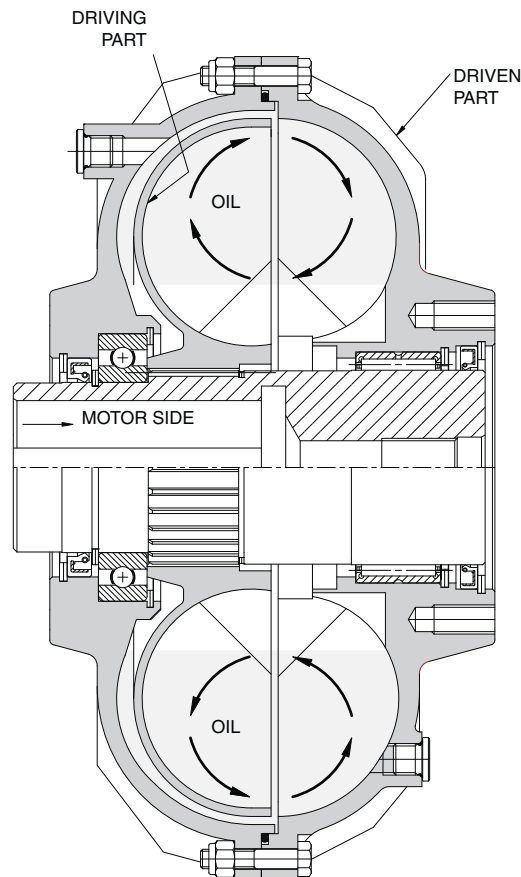

The ROTOFLUID fluid coupling is designed to provide your plant with optimum reliability and durability. It is fitted between the motor (drive) and machine (driven component).

The ROTOFLUID fluid coupling comprises basically two impellers, with radial blades, opposed to each other, one connected to the motor shaft and the other to the input shaft of the Driven Equipment or Machine.

The ROTOFLUID fluid coupling acts like a centrifugal clutch, by driving an impeller, the oil passing from the blades to the driven part, which acts as a driven impeller, transmits the power to the Equipment or Machine. The oil, which fills the fluid coupling, transfers the torque and also lubricates moving parts.

Fluid couplings are the easiest and cheapest way of creating a perfectly Flexible Drive Train, because no mechanical parts are necessary between the motor and the Equipment or Machine being driven.

Without mechanical parts, there is practically no wear.

Losses in the fluid coupling become power drops according to the following formula:

$$S\% = \frac{n_m - n_u}{n_m} \times 100$$

where:

$n_m$  = motor speed in rpm

$n_u$  = output speed from the fluid coupling in rpm

The elasticity of the fluid coupling solves problems of power peaks in conventional electric motors and the machines they drive.

### THE ADVANTAGES OF USING FLUID COUPLINGS

- easy start-up with gradual acceleration of the driven component
- automatic load speed adjustment on the basis of the synchronous speed of two or more motors
- the drive train is protected against overloads
- rotational vibrations are dampened
- the torque transmitted complies with pre-set values
- direct on-line start electric motors can be used, without star-delta starters or slip-ring motors with rheostat

### FITTING A ROTOFLUID FLUID COUPLING GIVES YOU THE FOLLOWING BENEFITS:

- a large range of accessories
- interchangeable accessories on the basic cell
- the dimensions of the shaft-pulley system are perfectly suited to the needs of the drive train
- all fluid couplings that utilise a belt drive, from Size 40P up, are fitted with ball bearings under the pulley to guarantee above-standard radial loads
- all the fluid couplings used for Horizontal applications are fitted with ROTOFLEXI Elastic Flexible coupling, which gives the advantage of, the user, of being able to replace the Flexible element, by removing it radially from the coupling, without either disturbing the Motor or the Driven Equipment or Machine



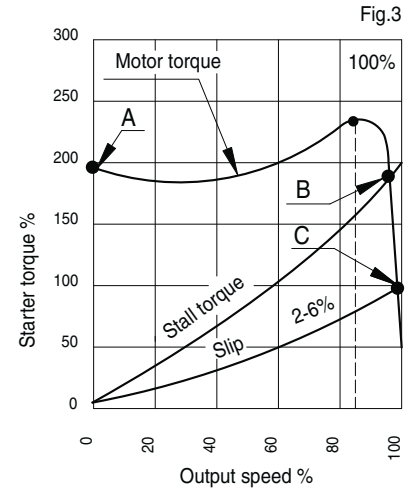
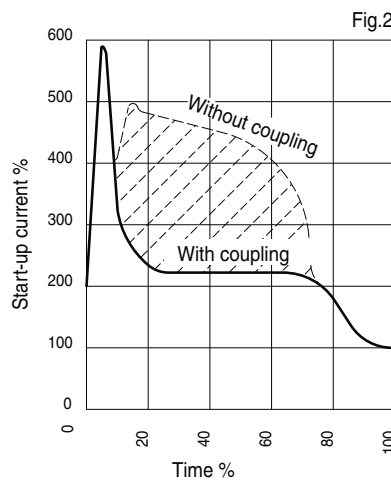
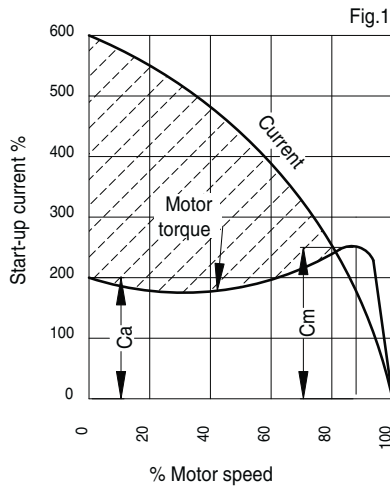

### START-UP WITHOUT FLUID COUPLING

Figure 1 represents the typical start-up of an electric motor directly coupled to the load. The dotted line represents the energy lost bringing the motor and load up to operating speed.

As can be seen, direct start-up has the following disadvantages:

- the difference between start-up torque ( $C_a$ ) and the load requirement ( $C_m$ ) is very low; the maximum torque is between 80%-85% of the operating speed.
- the current absorbed during start-up may be up to 6 times the rated current, causing electrical overloads and higher costs, an increase in motor temperature and fewer possible start-ups.

To limit peak currents, a characteristic of direct start-ups, a system with reduced voltage for start-ups must be used, most commonly the Y /  $\Delta$  system. In this way the current and peak torque are reduced by about 1/3 compared to direct starting.

The disadvantages of this type of start-up include:

- greater costs for wiring (2 3-pole cables per motor)
- high currents when switching from Y to  $\Delta$
- you cannot choose start-up features because current/torque parameters are pre-set and cannot be adjusted.
- It cannot be used for applications where the start-up requires a high load or resistant torque.

### START-UP WITH ROTOFUID FLUID COUPLING

With a ROTOFUID fluid coupling between the Motor and Driven Equipment or Machine the motor can start up directly and the starting torque ( $C_a$ ) is used solely to accelerate the rotor and primary part of the connected coupling.

Figure 2. shows the peak current of an electric motor directly connected to the load, with direct start-up, and start-up with a fluid coupling. The dotted line shows the energy lost as heat during start-up without a fluid coupling.

In the first case, the peak current is 6 times the rated current, and continues to be high until the operating speed is reached.

With a ROTOFUID fluid coupling, the peak current is high for only a few seconds (the energy required to accelerate the rotor) and drops to acceptable values throughout the process of reaching operating speed.

### CHARACTERISTIC CURVES FOR START-UP WITH FLUID COUPLING

Figure 3. shows a characteristic torque curve for an electric motor, the stall curve of the fluid coupling and the slip curve at operating speed.

The fluid coupling allows the motor to reach 80-85% speed in a few seconds (shift from point A to point B) where it meets the stall curve of the fluid coupling (slip=100%), the point of maximum motor torque.

Point C is the point of functioning of the fluid coupling after the motor has reached operating speed.

The use of a fluid coupling with a delay fill chamber limits maximum torque during start-up, without prejudicing slipping in normal functioning. This allows the motor to quickly increase speed [revs] without hitting the resistant torque (as if it started unloaded).

A Fluid coupling with a delay fill feature is fitted with additional chamber in order to reduce the quantity of oil in the working circuit (see Fig. 1). The chamber is in contact with the circuit via calibrated nozzles, which can be set as required (see Fig. 2).

The variation in the calibrated nozzle holes changes the time it takes for the oil in the chamber to reach the working circuit, thereby, increasing or decreasing start-up time for the driven machine.

When all the oil has flowed from the chamber into the circuit, the fluid coupling reaches the rated speed, transmitting the required torque with minimum slippage (see Fig. 3).

Fluid couplings may be fitted with either a single or dual delay fill chamber.

With a single delay fill chamber, Ca/Cn torque limitation varies from 180% to 150%, adjusting the quantity of oil.

With a dual delay fill chamber Ca/Cn torque limitation varies from 150% to 120%, adjusting the quantity of oil.

The advantages of delay fill chambers are enhanced as the power requirement rises.

SCF and DCF delay fill chambers are available from size 30 to size 95P.

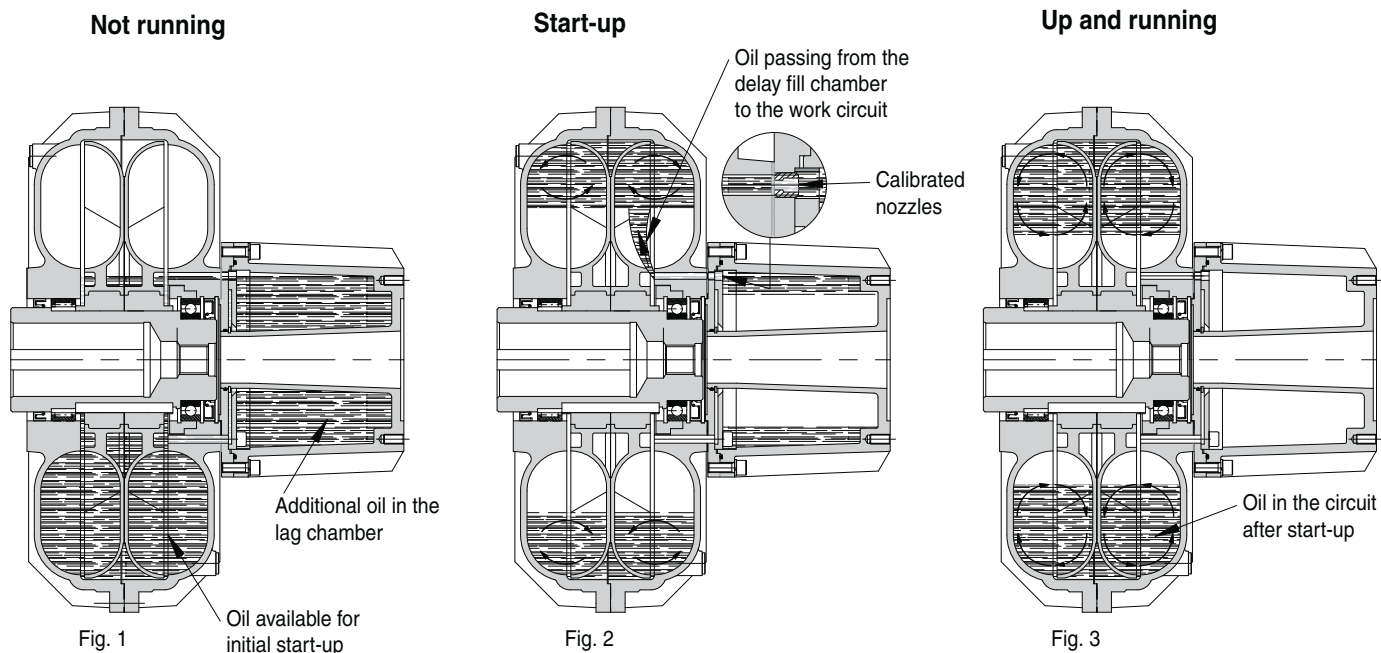

## ADVANTAGES

- Low energy loss even where inertia is high
- Start-up time can be adjusted
- Start-up torque is limited to pre-set values without affecting slip
- Limitation of start-up current prolongs the life of the motor
- For controls with several drives the coupling automatically adjusts the load speed on the basis of synchronous speed
- More start-ups per hour
- The direction of rotation can be reversed
- Asynchronous squirrel cage motors can be used instead of electric motors or special starting devices (Inductors, autotransformers, star-delta, etc.)
- If the load is blocked, both the motor and load are protected.

The **ROTOFLUID SCF/DCF** peculiarities are more evident comparing the curve of the ROTOFLUID coupling without delay chamber.

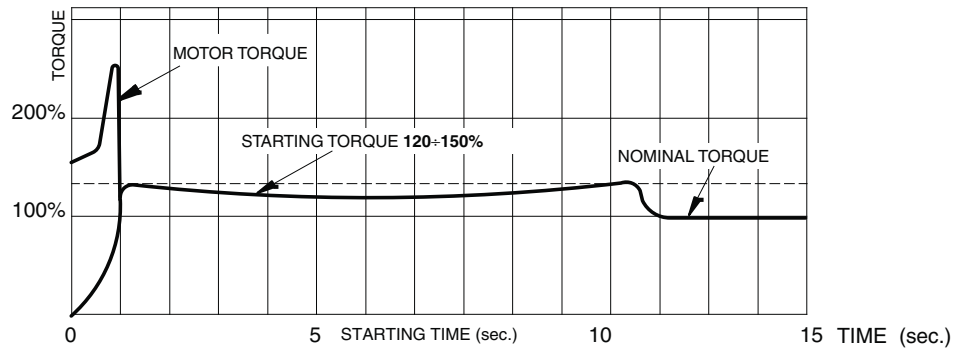
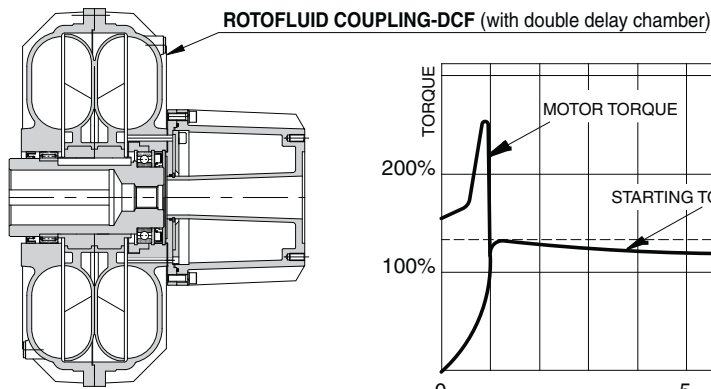
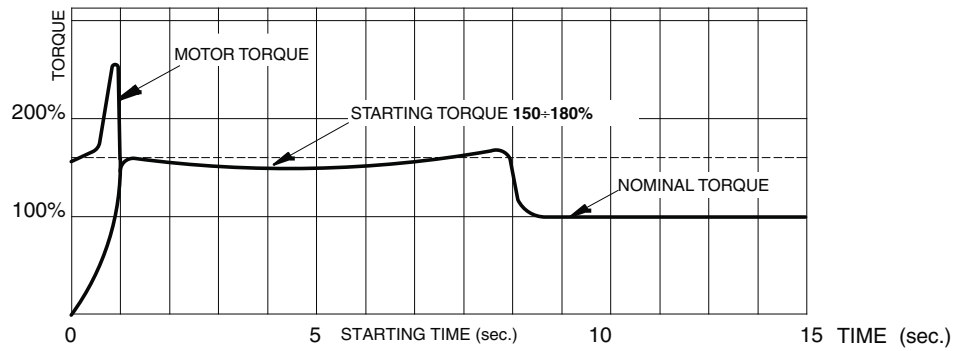
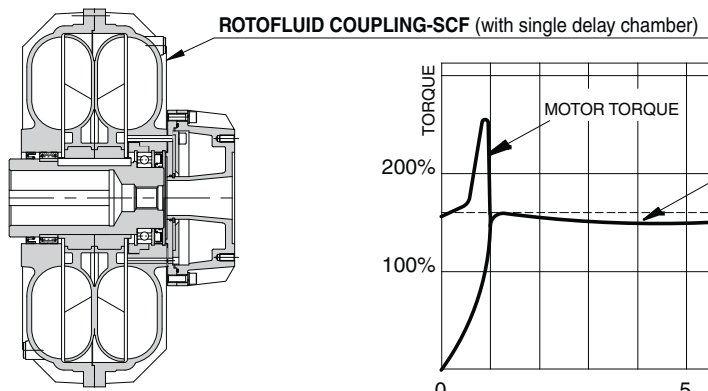
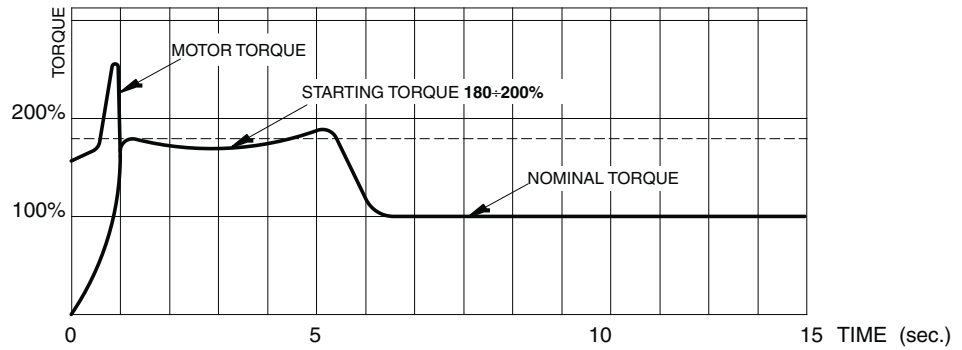
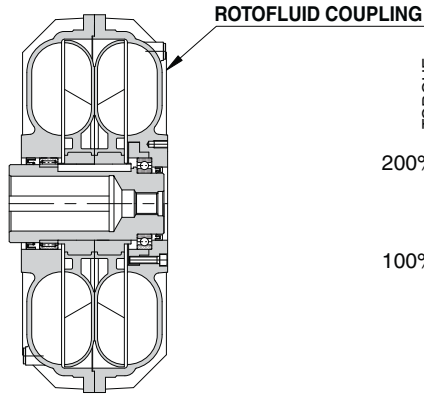

**CORRECT MOUNTING OF THE COUPLING WITH DELAY CHAMBER**

HORIZONTAL SHAFT

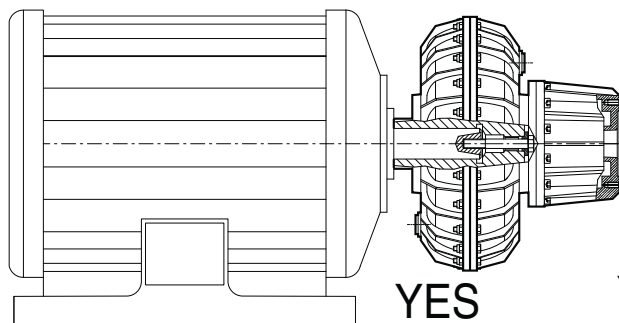

VERTICAL SHAFT WITH DOWNWARD DELAY CHAMBER

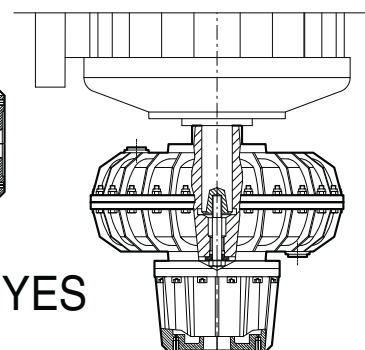

VERTICAL SHAFT WITH UPWARD DELAY CHAMBER

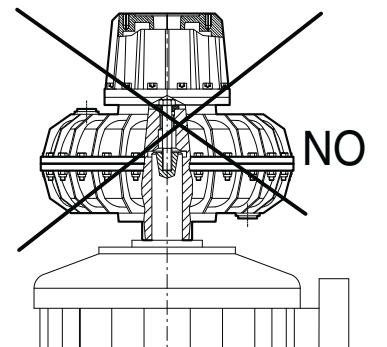

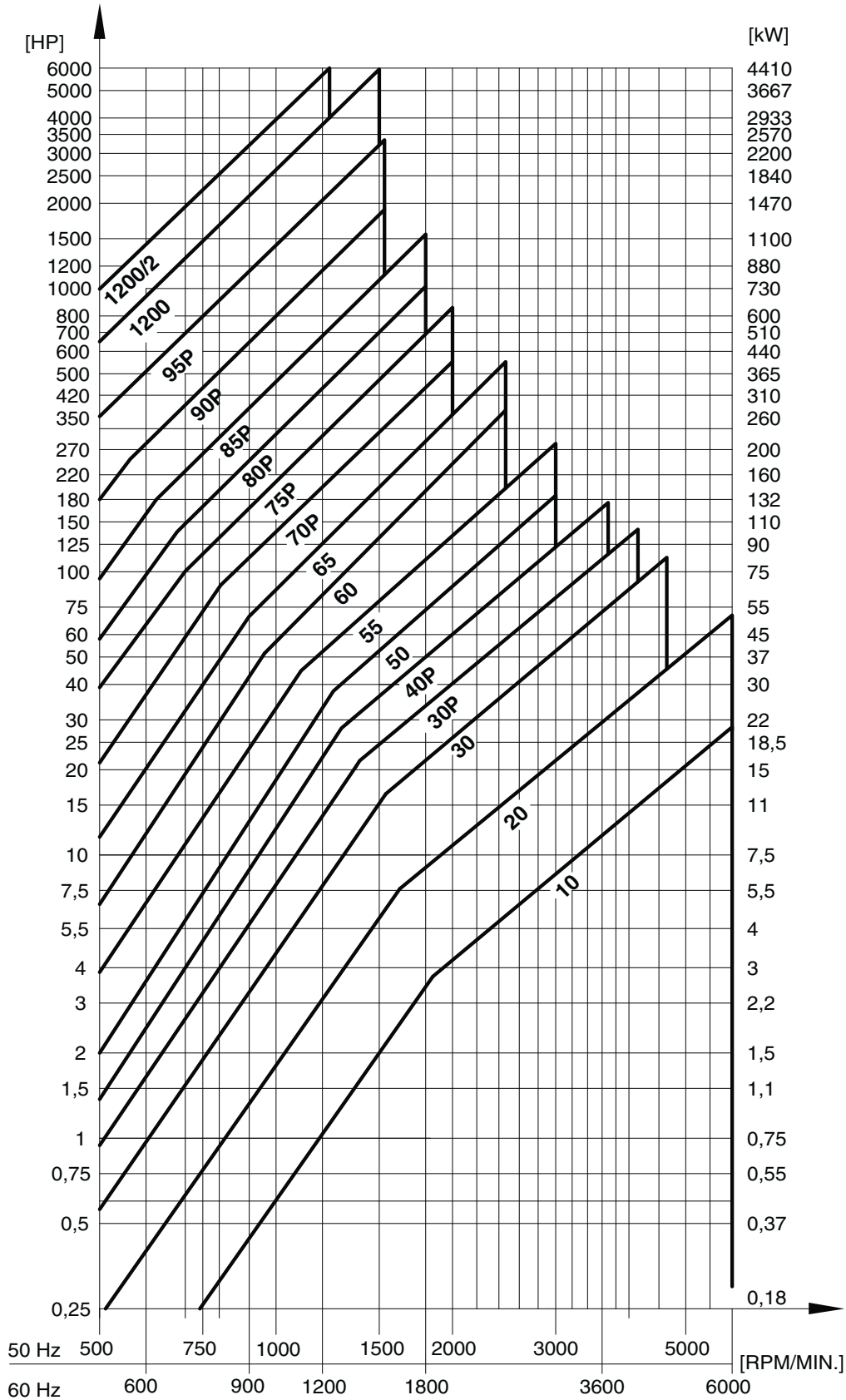

- Select coupling size on input power and speed.
- The curves show limit capacity of couplings.
- If the selection point falls on or close to the max capacity limit line of a given coupling size then it is advisable to check with the starting time and the maximum allowable temperature calculations.



MOTORS		Motor speed 50 Hz												Motor speed 60 Hz									
		8 poles			6 poles			4 poles			2 poles			6 poles			4 poles						
		750 R.P.M.			1000 R.P.M.			1500 R.P.M.			3000 R.P.M.			1200 R.P.M.			1800 R.P.M.						
TYPE	Ø SHAFT	kW	HP	Coupling	kW	HP	Coupling	kW	HP	Coupling	kW	HP	Coupling	kW	HP	Coupling	kW	HP	Coupling				
71	14				0,25	0,33	10	0,25	0,33	10	0,37	0,5	10	0,25	0,33	10	0,25	0,35	10				
80	19				0,37	0,5		0,37	0,5		0,55	0,75		0,75	1		0,37	0,5		0,55	0,75	0,37	0,5
90S	24				0,55	0,75	20	0,75	1	20	1,1	1,5	20	1,1	1,5	20	1,1	1,5	20				
90L	24	0,55	0,75	20	1,1	1,5		1,5	2		2,2	3		1,5	2		2,2	3		1,5	2	1,5	2
100L	28	1,1	1,5	30	1,5	2	30	2,2	3	30	3	4	30	3	4	30	3	4	30				
112M	28	1,5	2		2,2	3		3	4		4	5,5		4	5,5		4	5,5		4	5,5	4	5,5
132	38	-	-	30P	3	4	30P	5,5	7,5	30	5,5	7,5	30	5,5	7,5	30	5,5	7,5	20				
132M	38	3	4	40P	4	5,5		7,5	10		7,5	10		-	-		7,5	10		5,5	7,5	7,5	10
160M	42	4	5,5	50	7,5	10	40P	11	15	30P	11	15	30P	11	15	30P	11	15	30				
160L	42	7,5	10	55	11	15		15	20		18,5	25		15	20		18,5	25		11	15	15	20
180M	48	-	-		-	-	50	-	-	40P	-	-	30	-	-	40P	-	-	30P				
180L	48	11	15		15	20		18,5	25		22	30		-	-		15	20		22	30	18,5	25
200L	55	15	20	60	18,5	25	55	22	30	50	30	40	50	30	40	50	30	40	40P				
225S	60	18,5	25		-	-		37	50		-	-		-	-		-	-		-	-	37	50
225M	55	-	-	65	-	-	60	-	-	55	45	60	30P	45	60	55	-	-	50				
250M	60	-	-		30	40		45	60		-	-		55	75		40P	-		-	55	75	-
280S	65	-	-	70P	-	-	65	-	-	60	75	100	50	75	100	65	-	-	55				
280M	75	37	50		45	60		75	100		-	-		90	125		60	90		125	75	100	-
315S	65	-	-	75P	-	-	70P	-	-	65	-	-	50	-	-	65	-	-	60				
	80	55	75		75	100		110	150		-	-		110	150		65	110		150	75	100	-
	65	-	-	80P	-	-	75P	-	-	70P	-	-	55	-	-	75P	-	-	65				
	65	-	-		90	125		132	180		132	180		160	220		75P	132		180	160	220	90
315M	80	75	100	80P	110	150	75P	160	220	70P	200	270	70P	-	-	70P	160	220	70P	200	270		
355S	80	-	-	85P	-	-	80P	-	-	75P	-	-	75P	-	-	80P	-	-	75P				
	100	132	180		160	220		250	340		-	-		-	-		-	-		-	-	160	220
355M	80	-	-	90P	-	-	85P	-	-	75P	-	-	75P	-	-	80P	-	-	75P				
	100	160	220		200	270		315	430		-	-		-	-		-	-		-	-	200	270
		200	270	90P	250	340											250	340	80P				
NON STANDARD MOTORS		330	450	90P	370	500	85P	510	700	80P				310	420	80P	440	600	75P				
		600	800	95P	600	800	90P	810	1100	85P				440	600	85P	700	950	80P				
		1000	1360	1200	1000	1360	95P	1300	1740	90P				800	1100	90P	1000	1360	85P				
		1550	2100	1200/2	2000	2720	1200	2300	3100	95P				1380	1880	95P							
					3200	4350	1200/2	3850	5250	1200				2580	3500	1200							
														4200	5710	1200/2							

- For Couplings at 3000 RPM, ask for balancing required  
- Slip curves with Couplings efficiency are available on request

The preliminary selection of ROTOFLUID coupling, will be made on the selection diagram sheet 10 - 100A depending upon input power and speed. For frequent starts or high inertia acceleration, it is necessary first to carry out the following calculations:

- 1** Acceleration time (ta)
- 2** Max allowable temperature (Ta)
- 3** Max working cycles for hours (H)

For this purpose it is necessary to know:

**DATA**

Pm = INPUT POWER KW  
Nm = INPUT SPEED RPM  
(\*) Nu = COUPLING OUTPUT SPEED RPM  
PI = POWER ABSORBED BY THE LOAD AT RATED SPEED KW  
NI = SPEED OF DRIVEN MACHINE RPM  
T = AMBIENT TEMPERATURE °C

$J = \text{INERTIA OF DRIVEN MACHINE} \left( \frac{PD^2}{4} \right) \text{ kgm}^2$

$J_r = \text{INERTIA OF DRIVEN MACHINE REFERED TO COUPLING SHAFT} \text{ (kgm}^2\text{)} \quad J_r = J \left( \frac{NI}{Nu} \right)^2$

(\*)  $Nu = Nm \left( \frac{100 - S}{100} \right)$  WHERE: S = Percent slip of the ROTOFLUID coupling

The following assumptions may be made for initial calculations: S = 4

**1 ACCELERATION TIME**

For the calculation of the acceleration time apply the following formula:  
The outcome time is worded in seconds

$$ta = \frac{Nu \times Jr}{9,55 \times Ma} = \dots\dots\dots \text{ (sec)}$$

WHERE:

Ma = ACCELERATING TORQUE (Nm)

$$Ma = 1,65 \times Mm - MI = \dots\dots\dots \text{ (Nm)}$$

Mm = NOMINAL TORQUE (Nm)

$$Mm = \frac{9550 \times Pm}{Nm} = \dots\dots\dots \text{ (Nm)}$$

MI = ABSORBED TORQUE (Nm)

$$MI = \frac{9550 \times PI}{Nu} = \dots\dots\dots \text{ (Nm)}$$

**2 MAX ALLOWABLE TEMPERATURE**

For simplicity of calculation, ignore the heat dissipated during acceleration. Coupling temperature rise:

$$Ta = \frac{Q}{C} = \dots\dots\dots \text{ (}^\circ\text{C)}$$

WHERE:

Q = HEAT GENERATED DURING ACCELERATION (Kcal)  
C = TOTAL THERMAL CAPACITY OF COUPLING SELECTED FROM TABLE BESIDE

$$Q = \frac{Nu}{10^4} \left( \frac{J_r \times Nu}{76,5} + \frac{MI \times ta}{8} \right) = \dots\dots\dots \text{ (Kcal)}$$

The final coupling temperature reached at the end of the acceleration cycle will be:

$$Tf = T + Ta + TL \text{ (}^\circ\text{C)}$$

where: Tf = Final temperature (°C)  
T = Ambient temperature (°C)  
Ta = Temperature rise during acceleration (°C)  
TL = Temperature increase during steady running (°C)

$$TL = 2,4 \frac{PI \times S}{K} \text{ (}^\circ\text{C)}$$

where: K = factor from TAB. D

THERMAL CAPACITY OF ROTOFLUID COUPLINGS			TABLE C
Size	Without SCF/DCF Kcal / °C	With SCF Kcal / °C	With DCF Kcal / °C
10	0,73	-	-
20	1,2	-	-
30	2,8	3,1	3,3
30P	3,5	3,8	4
40P	4	4,7	5
50	6,1	6,9	7,4
55	8,8	9,6	10,1
60	13	14,8	16
65	15,2	17	18,2
70P	22	25,6	27,8
75P	28,6	32,2	34,4
80P	44	50	55
85P	55	61	66
90P	98	100	104
95P	133	138	142
1200	180	-	-
1200/2	250	-	-

**3 MAX WORKING CYCLES FOR HOUR H**

In addition to the heat generated in the coupling by slip during steady running, heat is also generated (as calculated above) during the acceleration period. To allow time for this heat to be dissipated, one must not exceed the max allowable number of acceleration cycles for hour. This is calculated as follows:

$$H_{max} = \frac{3600}{t_a + t_L}$$

where  $t_L$  = minimum working time

$$t_L = 10^3 \frac{Q}{\left(\frac{T_a}{2} + T_L\right) \cdot K} \text{ (sec)}$$

**WARNING:**

**ROTOFLUID couplings equipped with standard (NBR) oil seals must not exceed the maximum value T120°C.  
In the version with Viton seals the maximum value Tf = 180°C.**

In case the above performance calculations result shows unsuitable values, check again with a larger ROTOFLUID size or consult with Westcar technical office.

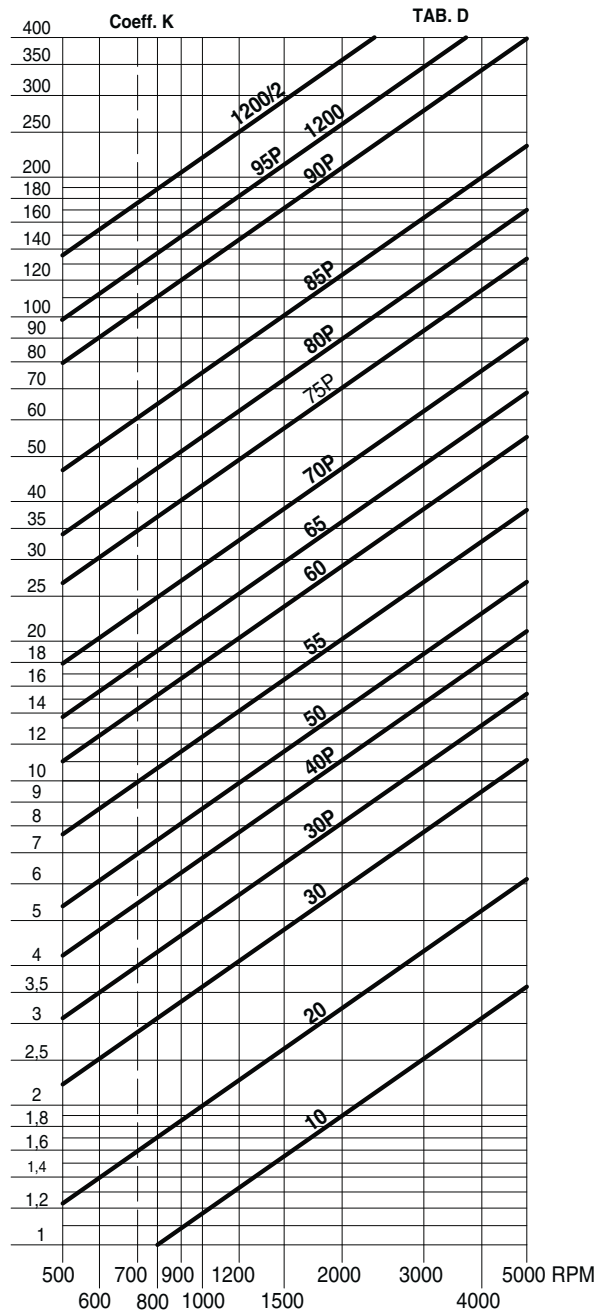

The mass moment of inertia values listed in the table below are referred to inner part, outer part and oil where:

INNER PART = hollow shaft, impeller pump, half oil

OUTER PART = turbine and cover housing, half oil

values valid for ROTOFLUID couplings with oil level at 45° off center pulleys, flexible couplings and other accessories are not included.

INNER PART	OUTER PART	INNER PART	OUTER PART	DELAY CHAMBER
SIZE: 10, 20, 30, 30P, 40P, 50, 60, 70P, 80P, 90P.		SIZE: 55, 65, 75P, 85P, 95P.		

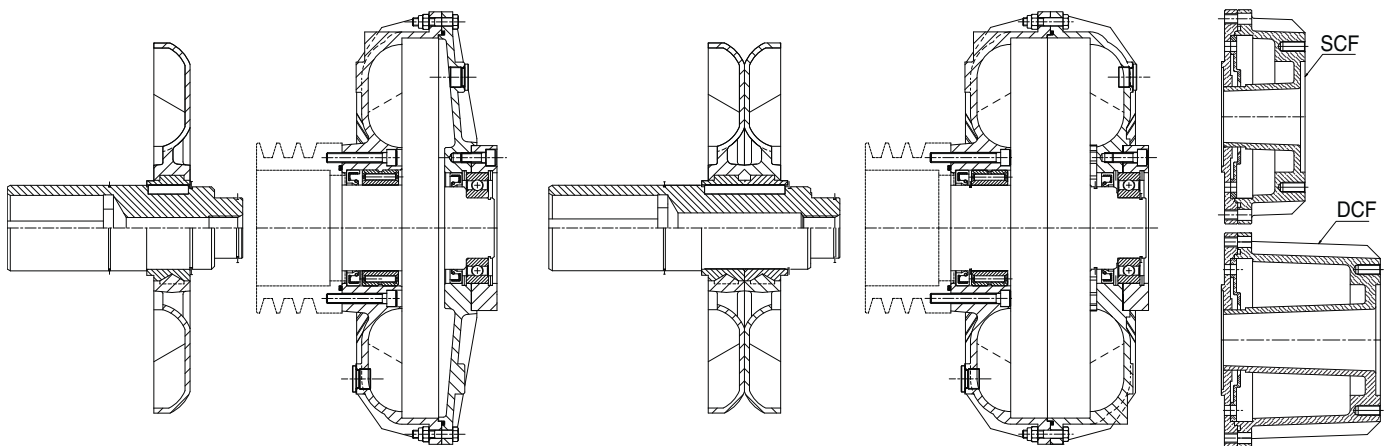

$$\text{MOMENT OF INERTIA } I = \frac{m \times R^2}{2} \text{ (Kgm}^2\text{)}$$

ROTOFLUID COUPLING SIZE	VERSION ALFA		VERSION BETA						DELAY CHAMBER	
	Type K		Type Z, X, I		Type J		Type H		SCF	DCF
	I INNER Kgm <sup>2</sup>	I OUTER Kgm <sup>2</sup>	I INNER Kgm <sup>2</sup>	I OUTER Kgm <sup>2</sup>	I INNER Kgm <sup>2</sup>	I OUTER Kgm <sup>2</sup>	I INNER Kgm <sup>2</sup>	I OUTER Kgm <sup>2</sup>	I Kgm <sup>2</sup>	I Kgm <sup>2</sup>
10	0,003	0,011	0,003	0,011	--	--	0,003	0,012	--	--
20	0,006	0,024	0,006	0,024	0,006	0,026	0,006	0,027	--	--
30	0,021	0,081	0,022	0,081	0,022	0,084	0,022	0,086	0,006	0,007
30P	0,040	0,140	0,045	0,140	0,045	0,144	0,045	0,147	0,006	0,007
40P	0,060	0,179	0,065	0,179	0,065	0,190	0,065	0,197	0,013	0,016
50	0,105	0,363	0,109	0,363	0,109	0,376	0,109	0,385	0,026	0,032
55	0,208	0,474	0,214	0,474	0,214	0,487	0,214	0,496	0,026	0,032
60	0,311	0,795	0,326	0,795	0,326	0,823	0,326	0,842	0,053	0,062
65	0,564	1,040	0,583	1,040	0,583	1,068	0,583	1,087	0,053	0,062
70P	0,710	2,230	0,780	2,230	0,780	2,307	0,780	2,357	0,11	0,140
75P	1,426	2,834	1,462	2,834	1,462	2,911	1,462	2,961	0,11	0,140
80P	2,389	7,276	2,499	7,276	2,499	7,393	--	--	0,215	0,254
85P	4,668	8,977	4,792	8,977	4,792	9,094	--	--	0,215	0,254
90P	8,372	23,200	--	--	--	--	--	--	0,490	0,550
95P	15,613	28,855	--	--	--	--	--	--	0,490	0,550
1200	54,000	260,000	--	--	--	--	--	--	--	--
1200/2	104,000	320,000	--	--	--	--	--	--	--	--

**ALL THE ACCESSORIES CAN BE FITTED TO THE COUPLINGS ALFA WITH DELAY  
FILL CHAMBERS "SCF AND DCF"**

**ROTOFLUID ALFA without accessories  
K**

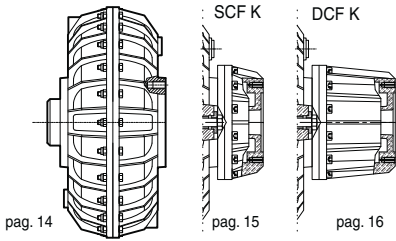

**ROTOFLUID ALFA KK reverse assembly  
with disc or brake drum**

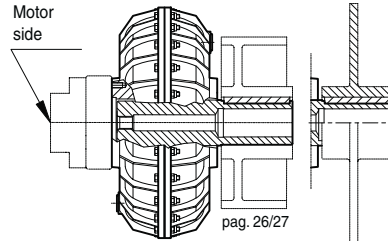

**ROTOFLUID ALFA KS with rigid stub shaft**

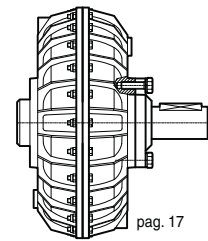

**ROTOFLUID ALFA K-LRV/LRU  
with standard ROTOFLEXI  
flexible coupling**

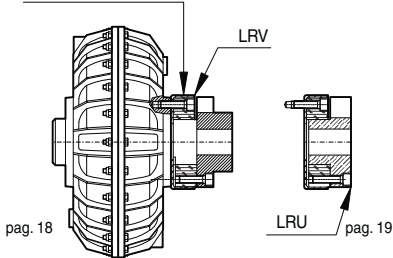

**ROTOFLUID ALFA K-FRV/FRU with  
ROTOFLEXI oversized flexible coupling**

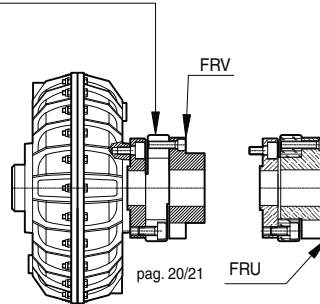

**ROTOFLUID ALFA K-AB with  
ROTOPIN flexible coupling**

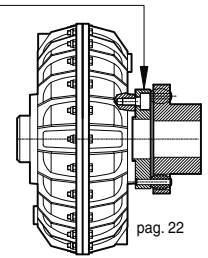

**ROTOFLUID ALFA K-FRD with ROTOFLEXI  
oversized flexible coupling and brake drum**

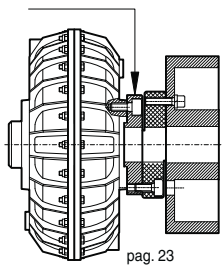

**ROTOFLUID ALFA K-AFF with ROTOPIN  
flexible coupling and brake drum**

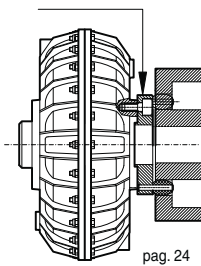

**ROTOFLUID ALFA K-FR-PAV/PBV  
with flexible coupling and brake disc**

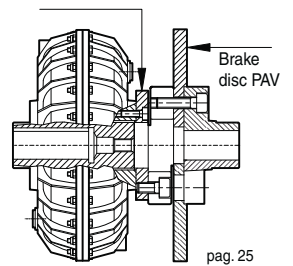

**ROTOFLUID ALFA WAG  
with flanges for the mounting of half  
gear couplings in inches**

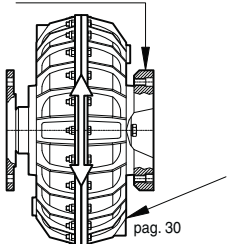

Fluid couplings radially  
demountable without  
moving the machines

**ROTOFLUID ALFA WAG-G with  
ROTOGEAR coupling**

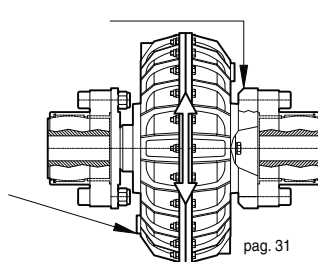

**ROTOFLUID ALFA CK-LRS**

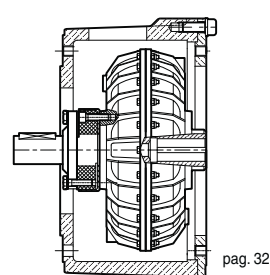

**SPECIAL CONFIGURATIONS EXAMPLES FOR COUPLING ROTOFLUID ALFA**

**ROTOFLUID ALFA K-W  
with flange shaft**

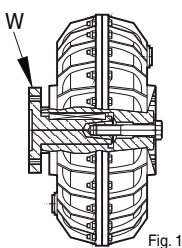

**ROTOFLUID ALFA K-Y  
with pin shaft**

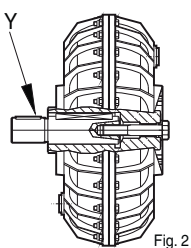

**ROTOFLUID ALFA K-VFW  
with rigid hub**

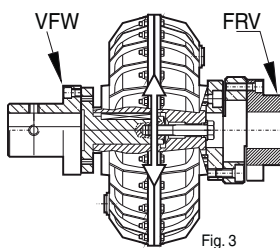

**ROTOFLUID ALFA K-VF  
for "reverse mounting"**

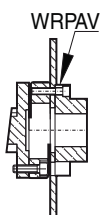
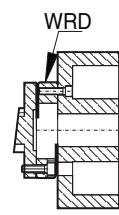
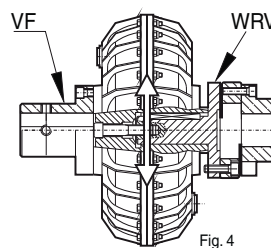



**STANDARD ASSEMBLY**

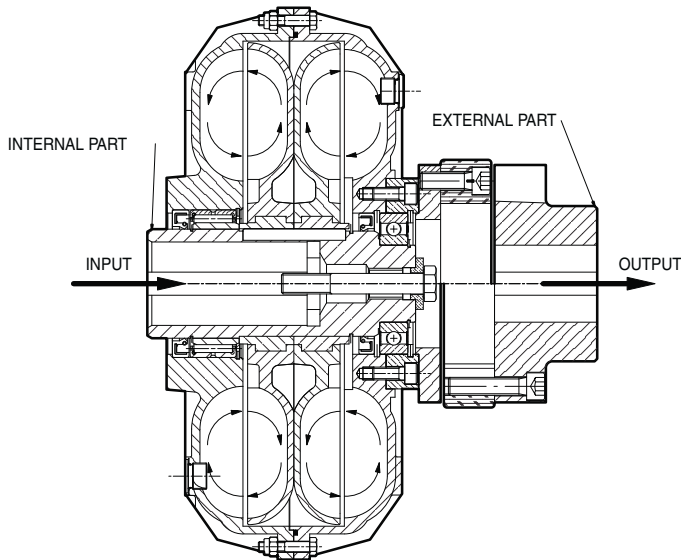

**REVERSE ASSEMBLY**

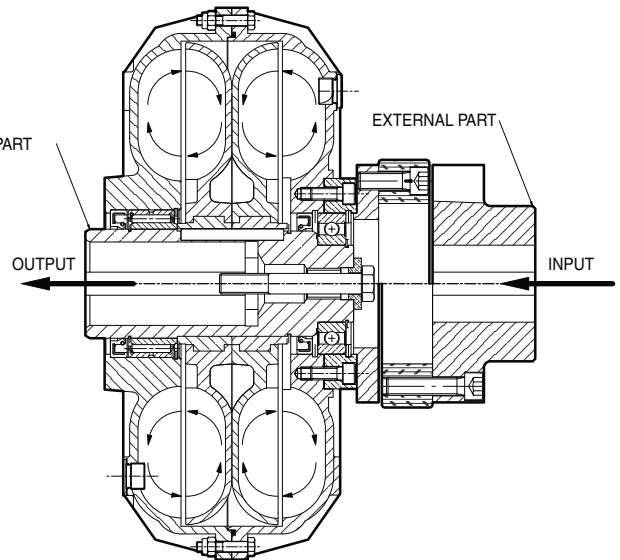

**ADVANTAGES OF STANDARD ASSEMBLY**

In STANDARD assemblies, the fluid coupling is fitted with the internal part keyed to the motor.

This is common for couplings with pulleys and linear couplings, and provides the following benefits:

- A) – Standardisation of bores in compliance with unified electric motor shafts;
- B) – During start-up the inertia of the coupling affects the motor less, so the motor can reach operating speed with less peak current;
- C) – In linear applications, where a brake disc/drum are required, they are keyed directly onto the reduction gear shaft without increasing the axial length of the coupling.
- D) – In couplings with delay fill chambers, start-up is more gradual because the oil passing from the delay fill chamber is subjected to centrifugal forces in the work chamber as revs rise;
- E) – The flexible coupling fitted to the fluid coupling is subject to less stress, because it receives motion from the fluid coupling not directly from the motor.

**ADVANTAGES OF REVERSE ASSEMBLY**

In a REVERSE assembly, the fluid coupling is fitted with the external part keyed to the motor.

This type of assembly is possible whenever the fluid coupling is fitted between the motor and the reduction gear.

For couplings with a Vee Pulley, the coupling must be fitted to the driving shaft and attention needs to be paid to the ratio between the Driving pulley and Driven pulley. (In this case consult WESTCAR S.R.L.)

This type of assembly has the following important benefits:

- F) - Greater dissipation of heat, above all during start-up, recommended where start-ups are frequent or lengthy;
- G) - Control is easier and the regulation of the oil level in the coupling is simplified, since the external part can be rotated without moving the Driven Equipment or Machine;
- H) - IMPORTANT! Where the coupling is fitted with THERMAL TRIP PIN, it continues to function even when the Driven Equipment or Machine comes to rest and the motor is rotating.

In the absence of special needs or requests, the coupling is supplied for the Standard configuration.

Please advise **WESTCAR S.R.L.** if you require, the selected Fluid Coupling to be quoted for Reverse Assembly.

**ROTOFLEXI flexible coupling**

**ROTOPIN flexible coupling**

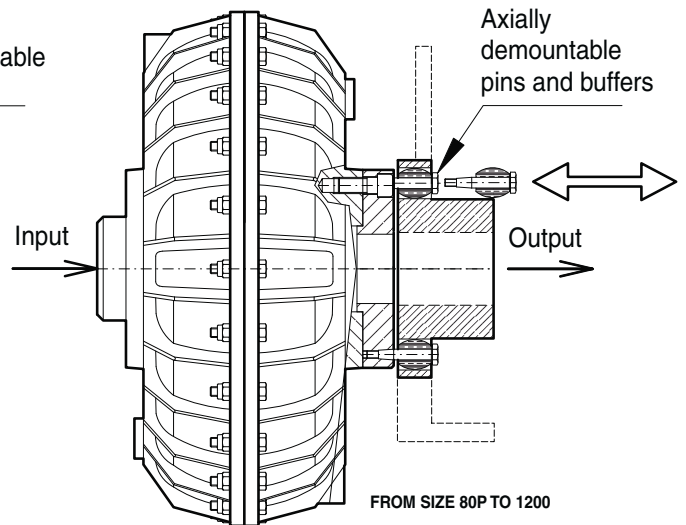
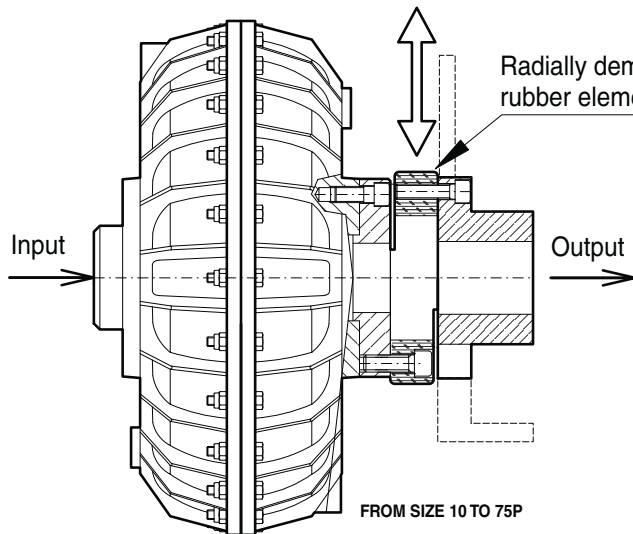

Rubber elements type « R » available also with reinforced fabric for higher torque applications' « BR ».

COUPLING	750 R.P.M.		COUPLING	1000 R.P.M.		COUPLING	1500 R.P.M.		COUPLING	3000 R.P.M.				
	HP	KW		HP	KW		HP	KW		CV/HP	KW			
20 K-LR..-2	0,75	0,55	10 K-LR..-1	0,33	0,25	10 K-LR..-1	0,33	0,25	10 K-LR..-1	1	0,75			
30 K-LR..-3	1,5	1,1	20 K-LR..-2	0,5	0,37		0,5	0,37		1,5	1,1			
30P K-LR..-3	2	1,5	30 K-LR..-3	0,75	0,55	0,75	0,55	2		1,5				
40P K-LR..-4	4	3	50 K-LR..-5	1	0,75	1	0,75	3		2,2				
50 K-LR..-5	5,5	4	60 K-LR..-6	1,5	1,1	1,5	1,1	4		3				
55 K-LR..-5	10	7,5	80P K-AB-8	2	1,5	2	1,5	5,5	4	7,5	5,5			
60 K-LR..-6	15	11	80P K-AB-8	3	2,2	20 K-LR..-2	3	2,2	20 K-LR..-2	10	7,5			
	20	15	30P K-LR..-3	4	3		4	3		15	11			
65 K-LR..-6	25	18,5	50 K-LR..-5	5,5	4	30 K-LR..-3	5,5	4	30 K-LR..-3	20	15			
	30	22	75P K-LR..-7	7,5	5,5		7,5	5,5		25	18,5			
65 K-FR..-7	40	30	80P K-AB-8	10	7,5	30P K-FR..-4	10	7,5	30 K-FR..-4	30	22			
70P K-LR..-7	50	37	55 K-LR..-5	15	11		15	11		40	30			
	75P K-FR..-8	60	45	60 K-LR..-6	20	15	40P K-FR..-5	20	15	30P K-FR..-4	50	37		
75		55	65 K-FR..-7	25	18,5	25		18,5	60		45			
80P K-AB-8	125	90	70P K-LR..-7	30	22	50 K-FR..-6	30	22	40P K-FR..-5	75	55			
	150	110	75P K-FR..-8	40	30		40	30		100	75			
85P AB-8M	180	132	80P K-AB-8	50	37	55 K-FR..-6	50	37	50 K-FR..-6	125	90			
	85P K-AB-8M	220	160	65 K-FR..-7	60		45	60		45	150	110		
90P K-AB-9		270	200	70P K-FR..-8	75	55	60 K-FR..-7	75	55	50 K-FR..-6x2	180	132		
	90P K-AB-9	450	330 ★	75P K-FR..-8	100	75		65 K-FR..-7	100		75	220	160	
95P K-AB-9		800	600 ★	75P KFR..-8x2	125	90	70P K-FR..-8		125	90	55 K-FR..-6x2	270	200	
	1200 K-AB-9	1600	1200 ★	80P K-AB-8	150	110		75P K-FR..-8	150	110		For higher power contact WESTCAR Technical Dept.		
For higher power contact WESTCAR Technical Dept.				80P K-AB-8	180	132	75P K-FR..-8x2		180	132				
	85P K-AB-8M			220	160	75P K-FR..-8x2		220	160					
	85P K-AB-8M			270	200	80P K-AB-8	270	200	80P K-AB-8	270	200			
	85P K-AB-8M			340	250	85P K-AB-8M	340	250		500	365 ★			
	85P K-AB-8M			500	370	90P K-AB-9	450	330 ★	85P K-AB-8M	500	370		600	450 ★
	90P K-AB-9			800	600 ★	95P K-AB-9	800	600 ★	90P K-AB-9	800	600 ★		700	525 ★
	95P K-AB-9			1360	1000 ★	1200 K-AB-9 (1)	1360	1000 ★	95P K-AB-9	1360	1000 ★		1100	810 ★
	1200 K-AB-9 (1)			2720	2000 ★				1200 K-AB-9 (1)	2720	2000 ★		1740	1300 ★
													3100	2300 ★

★ Maximum power transmitted by the fluid coupling for no standard motors.

(1) Check flexible coupling duty factor with the rated motor power

NOTE - For REVERSE MOUNTING advise WESTCAR

NOTE - For couplings running at 3000 R.P.M. contact WESTCAR Technical Dept.

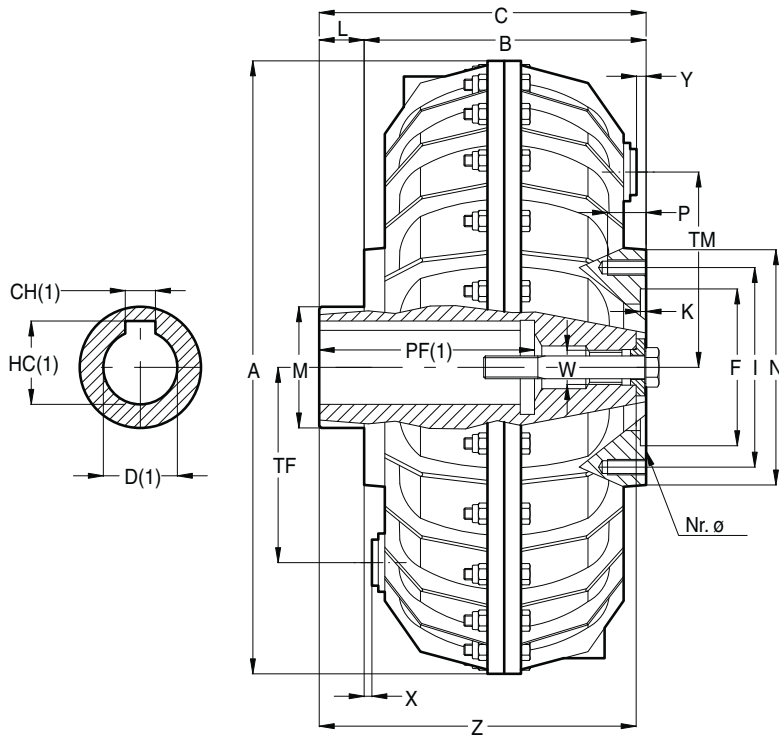

NOTE: (1) FOR BORE AND KEYWAY DIMENSIONS SEE SHEET 10-019D

Size	Type	Dimensions in mm																	Weight	
		D	A	B	C	F <sup>H7</sup>	K	I	L	M	N	Nr.Ø	P	TF	TM	W	X	Y	Z	Kg.*
10	K-1	14-19-24 28	193	88	98	47	4	60	10	35	75	6-M6	12	66	66	ø8,5	0,5	0	94	4
	K-3					28	2	26	40	9			0,5				112			
20	K-1	19-24-28 38	230	115	125	62	4	78	10	40	94	6-M8	16	80	80	M14 M16	2	7	120	6
	K-3					38	4	20	53	14			2				130			
30	K-1	28-38-42 48 **	290	150	162	75	4	100	12	55	114	8-M8	16	110	110	M24	9	9	157,5	13,2
	K-3					48 **			40	60									185,5	
	K-4					55			69	70									214,5	
30P	K-1	28-38-42 48 **	327	150	162	75	4	100	12	55	114	8-M8	16	130	130	M24	4	4	157,5	21
	K-3					48 **			40	60									185,5	
	K-4					55			69	70									214,5	
40P	K-1	38-42-48-55 60	338	183	198	100	4	125	15	70	145	8-M10	22	130	130	M24	11	24	194	22
	K-2					60			90	80			20				11	11	193	
50	K-2	42-48-55-60-65	430	154	179	110	4,5	140	25	85	165	8-M10	22	150	150	M24	6	20	176,5	30
55	K-2	42-48-55-60-65 75	430	196	211	110	4,5	140	15	85	165	8-M10	22	150	150	M24 M30	6	6	208,5	40
	K-3								75	14									100	
60	K-2	48-55-60-65-75 80	520	172	192	125	8	160	20	110	185	8-M10	22	205	192	M30	6	20	192	46
	K-3								80	50									110	
65	K-2	55-60-65-75-80	520	220	240	125	8	160	20	110	185	8-M10	22	205	205	M30	6	6	240	66
70P	K-2N	75-80-90 100	640	190	240	150	4	195	50	128	225	8-M16	30	265	265	M36	0	15	234	86
	K-3N								100	90									274	
75P	K-2N	80-90 100	640	245	265	150	4	195	20	128	225	8-M16	30	265	265	M36	0	0	254	127
	K-3N								100	35									269	
80P	K-2N	max. 110 max. 125***	810	226	270	160	5	230	44	160	270	8-M18	28	325	325	M36	0	15	264	180
	K-3N								max. 125***	60									280	
85P	K-2N	max. 125 max. 135	810	300	340	160	5	230	40	160	270	8-M18	28	325	325	M36	0	0	334	252
	K-3N								max. 135	170									270	
90P	K-2	max. 130 max. 140***	1000	344	364	445	5	506	20	170	550	16-M20	32	416	416	M36	0	35	343	350
	K-3								max. 140***	120									170	
95P	K-2	max. 130 max. 140***	1000	466	479	445	5	506	13	170	550	16-M20	32	416	416	M36	0	35	420	505
	K-3								max. 140***	120									170	
1200	K-2	max. 190	1300	425	462	220	7	310	7	240	570	16-M20	36	430	430	M36	0	30	419	1800

\* Weight with oil - \*\* Reduced keyway - \*\*\* Depth of bore PF = 210 (for larger bores consult WESTCAR) - Standard bores in heavy type

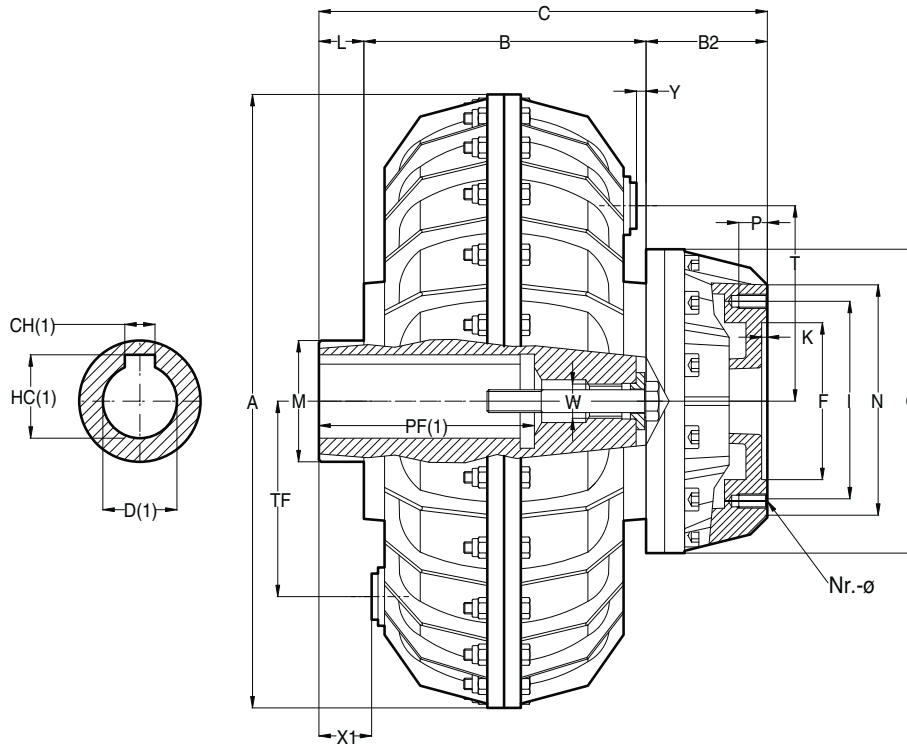

NOTE: (1) FOR BORE AND KEYWAY DIMENSIONS SEE SHEET 10-019D

Size	Dimensions mm																			Weight Kg.*	
	Type	D	A	B	C	B2	F <sup>H7</sup>	K	I	L	M	N	Nr.Ø	O	P	TF	TM	W	X1		Y
30 SCF	K-2	28-38-42			217		72			12	60								21	15,6	
	K-3	48 **	290	150	245	55	72	4	100	40	60	114	8-M8	156	16	110	110	M24	49	9	15,6
	K-4	55			274		72			69	70								78		16,4
30P SCF	K-2	28-38-42			217		72			12	60								16	23,4	
	K-3	48 **	327	150	245	55	72	4	100	40	60	114	8-M8	156	16	110	110	M24	44	4	23,4
	K-4	55			274		72			69	70								73		24,4
40P SCF	K-2	38-42-48-55-60	338	183	256	58	90	4	125	15	80	145	8-M10	185	20	130	130	M24	39	11	25,7
50 SCF	K-2	42-48-55-60-65	430	154	259	80	110	4,5	140	25	85	165	8-M10	213	22	150	150	M24	31	20	35,8
55 SCF	K-2	42-48-55-60-65	430	196	291	80	110	4,5	140	15	85	165	8-M10	213	22	150	150	M24	21	6	45,8
	K-3	75			290					14	100										
60 SCF	K-2	48-55-60-65-75	520	172	282	90	125	8	160	20	110	185	8-M10	245	22	205	192	M30	26	20	54,4
	K-3	80			312					50											
65 SCF	K-2	55-60-65-75-80	520	220	330	90	125	8	160	20	110	185	8-M10	245	22	205	205	M30	26	6	74,4
70P SCF	K-2N	75-80-90	640	190	350	110	150	4	195	50	128	225	8-M16	288	30	265	265	M36	50	15	99
	K-3N	100			390					90											
75P SCF	K-2N	80-90	640	245	375	110	150	4	195	20	128	225	8-M16	288	30	265	265	M36	20	0	140
	K-3N	100			390					35											
80P SCF	K-2N	max. 110	810	226	388	118	160	5	230	44	160	270	8-M18	375	28	325	325	M36	44	15	196
	K-3N	max. 125***			404					60											
85P SCF	K-2N	max. 125	810	300	458	118	160	5	230	40	160	270	8-M18	375	28	325	325	M36	40	0	268
	K-3N	max. 135			170																
90P SCF	K-2	max. 130	1000	344	424	120	445	5	506	20	170	550	16-M20	630	32	416	416	M36	20	35	390
	K-3	max. 140***			524					120											
95P SCF	K-2	max. 130	1000	466	599	120	445	5	506	13	170	550	16-M20	630	32	416	416	M36	13	35	545
	K-3	max. 140***			706					120											

\* Weight with oil - \*\* Reduced keyway - \*\*\* Depth of bore PF = 210 (for larger bores consult WESTCAR) - Standard bores in heavy type

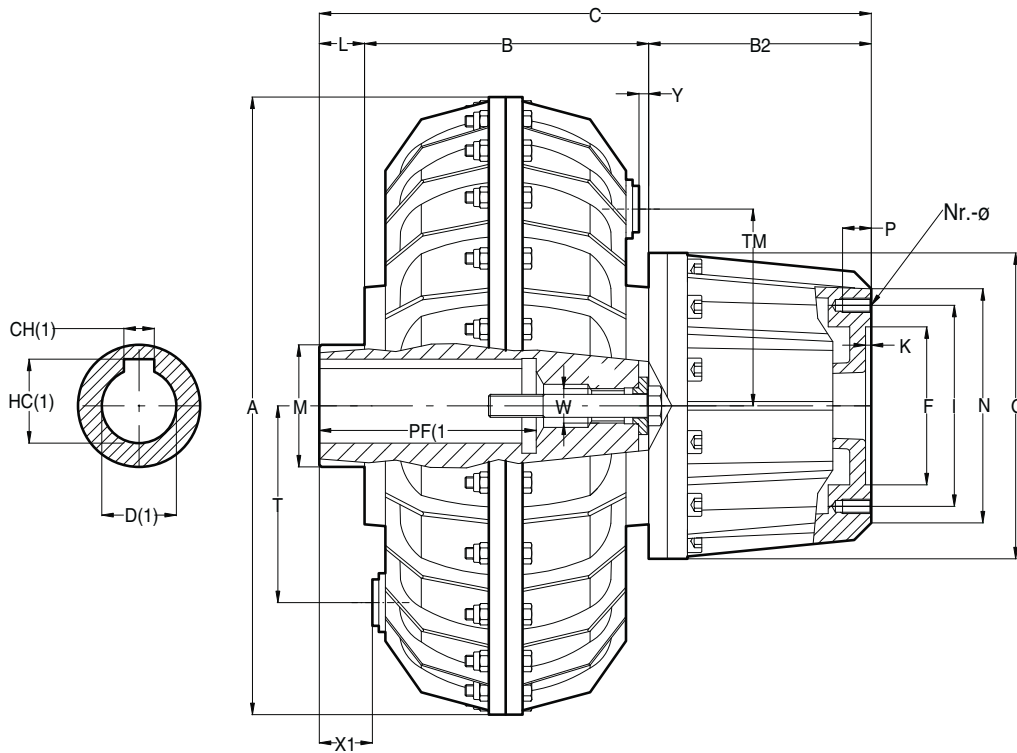

NOTE: (1) FOR BORE AND KEYWAY DIMENSIONS SEE SHEET 10-019D

Size	Dimensions mm																			Weight Kg.*	
	Type	D	A	B	C	B2	F <sup>H7</sup>	K	I	L	M	N	Nr.Ø	O	P	TF	TM	W	X1		Y
30 DCF	K-2	28-38-42	290	150	257	95	72	4	100	12	60	114	8-M8	156	16	110	110	M24	21	9	16,2
	K-3	48 **			285		72			40	60								78		16,2
	K-4	55			314		72			69	70								78		17,2
30P DCF	K-2	28-38-42	327	150	257	95	72	4	100	12	60	114	8-M8	156	16	110	110	M24	16	4	24
	K-3	48 **			285		72			40	60								44		24
	K-4	55			314		72			69	70								73		25
40P DCF	K-2	38-42-48-55-60	338	183	328	130	90	4	125	15	80	145	8-M10	185	20	130	130	M24	39	11	27,2
50 DCF	K-2	42-48-55-60-65	430	154	334	155	110	4,5	140	25	85	165	8-M10	213	22	150	150	M24	31	20	38
55 DCF	K-2	42-48-55-60-65	430	196	366	155	110	4,5	140	15	85	165	8-M10	213	22	150	150	M24	21	6	48
	K-3	75			365					14	100							20	56		
60 DCF	K-2	48-55-60-65-75	520	172	362	170	125	8	160	20	110	185	8-M10	245	22	205	192	M30	26	20	58
K-3	80	392			50					56	20										
65 DCF	K-2	55-60-65-75-80	520	220	410	170	125	8	160	20	110	185	8-M10	245	22	205	205	M30	26	6	78
70P DCF	K-2N	75-80-90	640	190	465	225	150	4	195	50	128	225	8-M16	288	30	265	265	M36	50	15	106
	K-3N	100			505					90	90							20			
75P DCF	K-2N	80-90	640	245	490	225	150	4	195	20	128	225	8-M16	288	30	265	265	M36	20	0	147
	K-3N	100			505					35	35							20			
80P DCF	K-2N	max. 110	810	226	488	218	160	5	230	44	160	270	8-M18	375	28	325	325	M36	44	15	208
	K-3N	max. 125***			504					60	60							44			
85P DCF	K-2N	max. 125	810	300	558	218	160	5	230	40	160	270	8-M18	375	28	325	325	M36	40	0	280
	K-3N	max. 135			170					170	40										
90P DCF	K-2	max. 130	1000	344	504	200	445	5	506	20	170	550	16-M20	630	32	416	416	M36	20	35	405
	K-3	max. 140***			604					120	120							20			
95P DCF	K-2	max. 130	1000	466	679	200	445	5	506	13	170	550	16-M20	630	32	416	416	M36	13	35	560
	K-3	max. 140***			786					120	120							13			

\* Weight with oil - \*\* Reduced keyway - \*\*\* Depth of bore PF = 210 (for larger bores consult WESTCAR) - Standard bores in heavy type



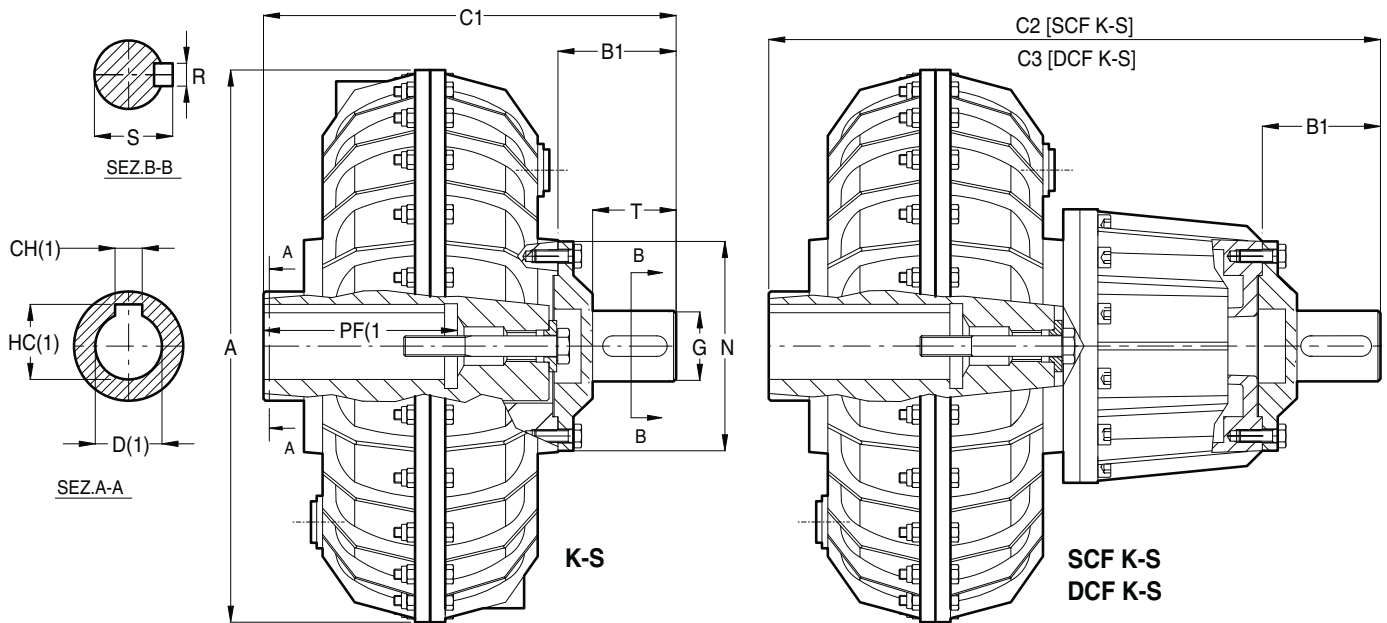

NOTE: (1) FOR BORE AND KEYWAY DIMENSIONS SEE SHEET 10-019D

Size	K-S											SCF K-S			DCF K-S		
	Dimensions mm.										Weight Kg. *	Dimensions mm.		Weight Kg. *	Dimensions mm.		Weight Kg. *
	Type	D	A	B1	C1	G h6	N	R	S	T		Type	C2		Type	C3	
10	K-1-S K-3-S	14-19-24 28	193	35	133 149	19	75	6	21,5	25	4,4	-	-	-	-	-	-
20	K-1-S K-3-S	19-24-28 38	230	44	169 179	24	94	8	27	32	6,7	-	-	-	-	-	-
30	K-1-S K-3-S K-4-S	28-38-42 48** 55	290	63	225 253 282	38	114	10	41	45	14,5	SCF K-2-S SCF K-3-S SCF K-4-S	280 308 337	16,9	DCF K-2-S DCF K-3-S DCF K-4-S	320 348 377	17,5 17,5 18,5
30P	K-1-S K-3-S K-4-S	28-38-42 48** 55	327	63	225 253 282	38	114	10	41	45	22,3	SCF K-2-S SCF K-3-S SCF K-4-S	280 308 337	24,7	DCF K-2-S DCF K-3-S DCF K-4-S	320 348 377	25,3 25,3 26,3
40P	K-1-S K-2-S	38-42-48-55 60	338	76	274	48	145	14	51,5	55	24,5	SCF K-2-S SCF K-2-S	332	28,2	DCF K-2-S DCF K-2-S	404	29,7
50	K-2-S	42-48-55-60-65	430	92	271	55	165	16	59	65	34	SCF K-2-S	351	39,8	DCF K-2-S	426	42
55	K-2-S K-3-S	42-48-55-60-65 75	430	92	303 302	55	165	16	59	65	44	SCF K-2-S SCF K-3-S	383 382	49,8	DCF K-2-S DCF K-3-S	458 457	52
60	K-2-S K-3-S	48-55-60-65-75 80	520	110	302 332	60	185	18	64	80	52	SCF K-2-S SCF K-3-S	392 422	60,4	DCF K-2-S DCF K-3-S	472 502	64
65	K-2-S	55-60-65-75-80	520	110	350	60	185	18	64	80	72	SCF K-2-S	440	80,4	DCF K-2-S	520	84
70P	K-2N-S K-3N-S	65-75-80-90 100	640	122	362 402	70	225	20	74,5	90	96	SCF K-2N-S SCF K-3N-S	472 512	109	DCF K-2N-S DCF K-3N-S	587 627	116
75P	K-2N-S K-3N-S	75-80-90 100	640	122	387 402	70	225	20	74,5	90	137	SCF K-2N-S SCF K-3N-S	497 512	150	DCF K-2N-S DCF K-3N-S	612 627	157
80P	K-2N-S K-3N-S	max. 110 max. 125***	810	145	415 431	80	270	22	85	110	197	SCF K-2N-S SCF K-3N-S	533 549	213	DCF K-2N-S DCF K-3N-S	633 649	225
85P	K-2N-S K-3N-S	max. 125 max. 135	810	145	485	80	270	22	85	110	269	SCF K-2N-S SCF K-3N-S	603	285	DCF K-2N-S DCF K-3N-S	703	297
90P	K-2-S K-3-S	max. 130 max. 140***	1000	220	584 684	110	550	28	116	180	418	SCF K-2-S SCF K-3-S	704 804	458	DCF K-2-S DCF K-3-S	784 884	473 513
95P	K-2-S K-3-S	max. 130 max. 140***	1000	220	699 806	160	550	40	169	180	595	SCF K-2-S SCF K-3-S	819 926	635	DCF K-2-S DCF K-3-S	899 1006	650 700
1200	K-2-S	max. 190	1300	290	752	180	550	45	190	250	1900	-	-	-	-	-	-

\* Weight with oil - \*\* Reduced keyway - \*\*\* Depth of bore PF = 210 (for larger bores consult WESTCAR) - Standard bores in heavy type

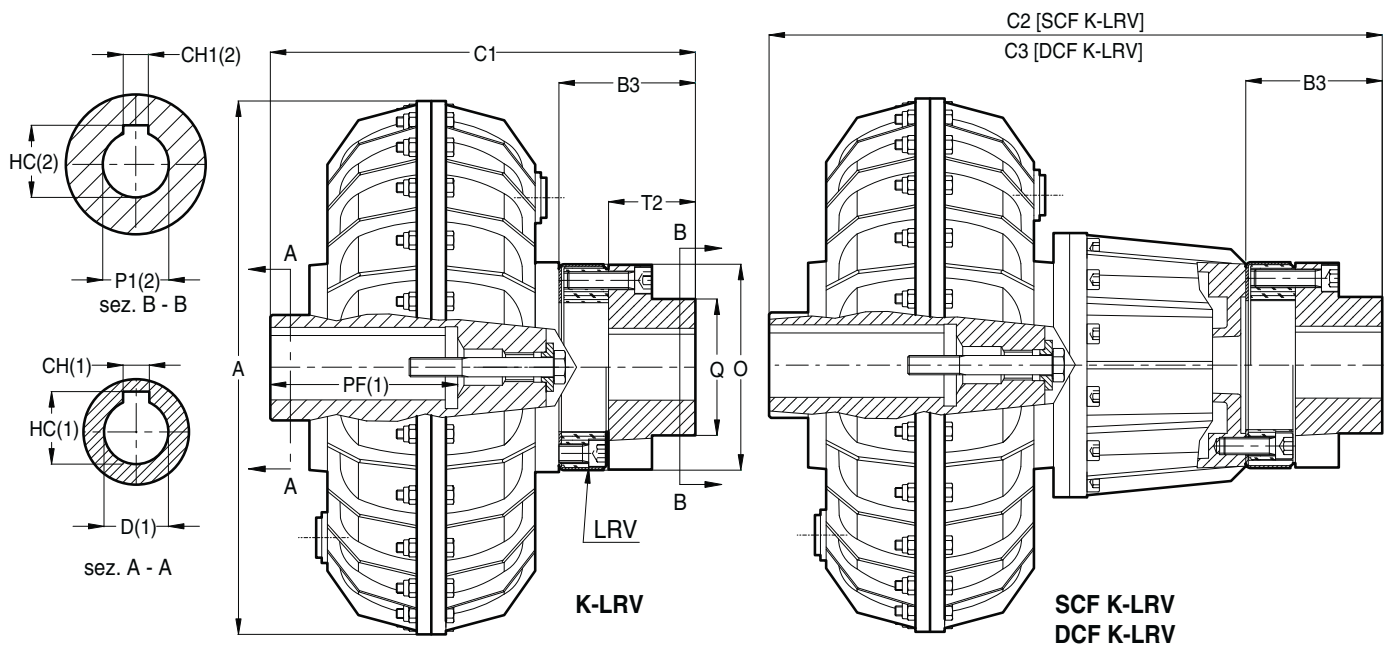

NOTE: (1) FOR BORE AND KEYWAY DIMENSIONS SEE SHEET 10-019D  
(2) UPON REQUEST: BORE P1 MACHINED SEE SHEET 10-023A

Size.	K-LRV										SCF K-LRV			DCF K-LRV		
	Type	D	A	B3	C1	O	P1 Max.	Q	T2	Weight Kg.*	Type	C2	Weight Kg.*	Type	C3	Weight Kg.*
10	K-1-LRV-1 K-3-LRV-1	14-19-24 28	193	50	148 164	84	28	45	30	4,7	-	-	-	-	-	-
20	K-1-LRV-2 K-3-LRV-2	19-24-28 38	230	69	194 204	104	38	56	45	7,6	-	-	-	-	-	-
30	K-01-LRV-3	28-38-42	290	87	249	130	48	68	55	16,2	SCF K-02-LRV-3	304	18,6	DCF K-02-LRV-3	344	19,2
	K-03-LRV-3	48 **			277					16,2	SCF K-03-LRV-3	332	18,6	DCF K-03-LRV-3	372	19,2
	K-04-LRV-3	55			306					17,2	SCF K-04-LRV-3	361	19,6	DCF K-04-LRV-3	401	20,2
30P	K-01-LRV-3	28-38-42	327	87	249	130	48	68	55	24	SCF K-02-LRV-3	304	26,4	DCF K-02-LRV-3	344	27
	K-03-LRV-3	48 **			277					24	SCF K-03-LRV-3	332	26,4	DCF K-03-LRV-3	372	27
	K-04-LRV-3	55			306					25	SCF K-04-LRV-3	361	27,4	DCF K-04-LRV-3	401	28
40P	K-01-LRV-4 K-02-LRV-4	38-42-48-55 60	338	96	294	158	60	91	60	27,2	SCF K-02-LRV-4 SCF K-02-LRV-4	352 352	30,9	DCF K-02-LRV-4 DCF K-02-LRV-4	424 424	32,4
50	K-02-LRV-5	42-48-55-60-65	430	110	289	176	70	106	70	37,6	SCF K-02-LRV-5	369	43,4	DCF K-02-LRV-5	444	45,6
55	K-02-LRV-5	42-48-55-60-65	430	110	321	176	70	106	70	47,6	SCF K-02-LRV-5	401	53,4	DCF K-02-LRV-5	476	55,6
	K-03-LRV-5	75			320						SCF K-03-LRV-5	400		475		
60	K-02-LRV-6	48-55-60-65-75	520	124	316	195	80	121	80	59	SCF K-02-LRV-6	406	65,3	DCF K-02-LRV-6	486	69,7
	K-03-LRV-6	80			346						SCF K-03-LRV-6	436		516		
65	K-02-LRV-6	55-60-65-75-80	520	124	364	195	80	121	80	76,9	SCF K-02-LRV-6	454	85,3	DCF K-02-LRV-6	534	89,7
	K-03-LRV-6	80			364						SCF K-03-LRV-6	454		534		
70P	K-2N-LRV-7	65-75-80-90	640	140	380	236	100	146	90	104,3	SCF K-2N-LRV-7	490	117,3	DCF K-2N-LRV-7	605	124,3
	K-3N-LRV-7	100			420						SCF K-3N-LRV-7	530		645		
75P	See type "K-FRV"										See type "SCF K-FRV"			See type "DCF K-FRV"		
80P	Available with flexible coupling ROTOPIN AB - See type "K-AB"										See type "SCF K-AB"			See type "DCF K-AB"		
85P																
90P																
95P																

\* Weight with oil - \*\* Reduced keyway - Standard bores in heavy type

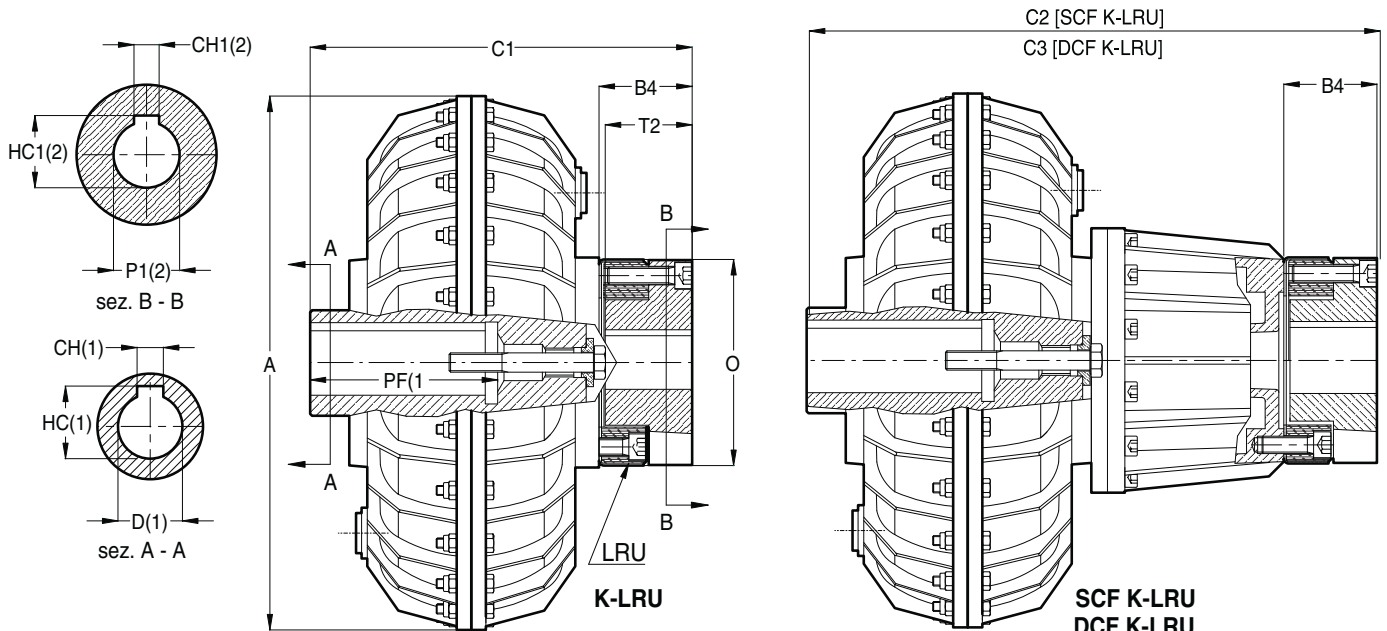

The rubber elements is not radially removable

NOTE: (1) FOR BORE AND KEYWAY DIMENSIONS SEE SHEET 10-019D  
(2) UPON REQUEST: BORE P1 MACHINED SEE SHEET 10-023A

Size	K-LRU									SCF K-LRU			DCF K-LRU		
	Type	D	A	B4	C1	O	P1 Max.	T2	Kg. *	Type	C2	Kg. *	Type	C3	Kg. *
10	K-1-LRU-1 K-3-LRU-1	14-19-24 28	193	35	133 149	84	28	30	4,7	-	-	-	-	-	-
20	K-1-LRU-2 K-3-LRU-2	19-24-28 38	230	49	174 184	104	32	45	7,6	-	-	-	-	-	-
30	K-01-LRU-3 K-03-LRU-3 K-04-LRU-3	28-38-42 48 ** 55	290	62	224 252 281	130	48	55	16,2 16,2 17,2	SCF K-02-LRU-3 SCF K-03-LRU-3 SCF K-04-LRU-3	279 307 336	18,6 18,6 19,6	DCF K-02-LRU-3 DCF K-03-LRU-3 DCF K-04-LRU-3	319 347 376	19,2 19,2 20,2
30P	K-01-LRU-3 K-03-LRU-3 K-04-LRU-3	28-38-42 48 ** 55	327	62	224 252 281	130	48	55	24 24 25	SCF K-02-LRU-3 SCF K-03-LRU-3 SCF K-04-LRU-3	279 307 336	26,4 26,4 27,4	DCF K-02-LRU-3 DCF K-03-LRU-3 DCF K-04-LRU-3	319 347 376	27 27 28
40P	K-01-LRU-4 K-02-LRU-4	38-42-48-55 60	338	66	264	158	60	60	27,2	SCF K-02-LRU-4 SCF K-02-LRU-4	322 322	30,9 30,9	DCF K-02-LRU-4 DCF K-02-LRU-4	394 394	32,4 32,4
50	K-02-LRU-5	42-48-55-60-65	430	75	254	176	70	70	37,6	SCF K-02-LRU-5	334	43,4	DCF K-02-LRU-5	409	45,6
55	K-02-LRU-5 K-03-LRU-5	42-48-55-60-65 75	430	75	286 285	176	70	70	47,6	SCF K-02-LRU-5 SCF K-03-LRU-5	366 365	53,4	DCF K-02-LRU-5 DCF K-03-LRU-5	441 440	55,6
60	K-02-LRU-6 K-03-LRU-6	48-55-60-65-75 80	520	84	276 306	195	80	80	5,9	SCF K-02-LRU-6 SCF K-03-LRU-6	366 396	65,3	DCF K-02-LRU-6 DCF K-03-LRU-6	446 476	69,7
65	K-02-LRU-6	55-60-65-75-80	520	84	324	195	80	80	76,9	SCF K-02-LRU-6	414	85,3	DCF K-02-LRU-6	494	89,7
70P	K-2N-LRU-7 K-3N-LRU-7	65-75-80-90 100	640	95	335 375	236	100	90	104,3	SCF K-2N-LRU-7 SCF K-3N-LRU-7	445 485	117,3	DCF K-2N-LRU-7 DCF K-3N-LRU-7	560 600	124,3
75P	See type "K-FRV"									See type "SCF K-FRV"			See type "DCF K-FRV"		
80P	Available with flexible coupling ROTOPIN AB - See type "K-AB"									See type "SCF K-AB"			See type "DCF K-AB"		
85P															
90P															
95P															

\* Weight with oil - \*\* Reduced keyway - Standard bores in heavy type

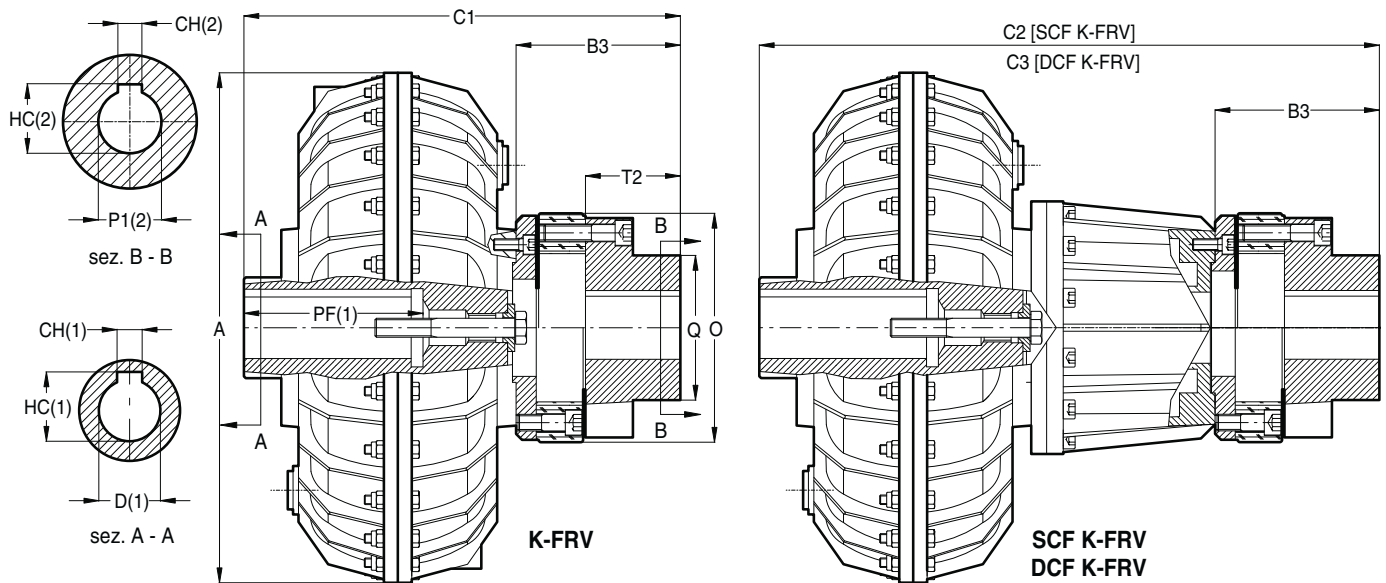

NOTE: (1) FOR BORE AND KEYWAY DIMENSIONS SEE SHEET 10-019D (2) UPON REQUEST: BORE P1 MACHINED SEE SHEET 10-023A

Size	K-FRV										SCF K-FRV			DCF K-FRV		
	Type	D	A	B3	C1	O	P1 Max.	Q	T2	Weight Kg*	Type	C2	Weight Kg*	Type	C3	Weight Kg*
10	K-1-FRV-2 K-3-FRV-2	14-19-24 28	193	77	175 191	100	38	56	45	5,8	-	-	-	-	-	-
20	K-1-FRV-3 K-3-FRV-3	19-24-28 38	230	98	223 233	126	48	68	55	9,6	-	-	-	-	-	-
30	K-1-FRV-4 K-3-FRV-4 K-4-FRV-4	28-38-42 48 ** 55	290	111	273 301 330	153	60	91	60	19,5 19,5 20,5	SCF K-2-FRV-4 SCF K-3-FRV-4 SCF K-4-FRV-4	328 356 385	21,9 21,9 22,9	DCF K-2-FRV-4 DCF K-3-FRV-4 DCF K-4-FRV-4	368 396 425	22,5 22,5 23,5
30P	K-1-FRV-4 K-3-FRV-4 K-4-FRV-4	28-38-42 48 ** 55	327	111	273 301 330	153	60	91	60	27,3 27,3 28,3	SCF K-2-FRV-4 SCF K-3-FRV-4 SCF K-4-FRV-4	328 356 385	29,7 29,7 30,7	DCF K-2-FRV-4 DCF K-3-FRV-4 DCF K-4-FRV-4	368 396 425	30,3 30,3 31,3
40P	K-1-FRV-5 K-2-FRV-5	38-42-48-55 60	338	125	323	170	70	106	70	31	SCF K-2-FRV-5 SCF K-2-FRV-5	381	34,7	DCF K-2-FRV-5 DCF K-2-FRV-5	453	36,2
50	K-2-FRV-6	42-48-55-60-65	430	139	318	190	80	121	80	42,5	SCF K-2-FRV-6	398	48,3	DCF K-2-FRV-6	473	50,5
55	K-2-FRV-6 K-3-FRV-6	42-48-55-60-65 75	430	139	350 349	190	80	121	80	52,5	SCF K-2-FRV-6 SCF K-3-FRV-6	430 429	58,3	DCF K-2-FRV-6 DCF K-3-FRV-6	505 504	60,5
60	K-2-FRV-7 K-3-FRV-7	48-55-60-65-75 80	520	163	355 385	232	100	146	90	69	SCF K-2-FRV-7 SCF K-3-FRV-7	445 475	77,4	DCF K-2-FRV-7 DCF K-3-FRV-7	525 555	81
65	K-2-FRV-7	55-60-65-75-80	520	163	403	232	100	146	90	89	SCF K-2-FRV-7	493	97,4	DCF K-2-FRV-7	573	101
70P	K-2N-FRV-8 K-3N-FRV-8	65-75-80-90 100	640	194	434 474	271	110	156	110	123	SCF K-2N-FRV-8 SCF K-3N-FRV-8	544 584	136	DCF K-2N-FRV-8 DCF K-3N-FRV-8	659 699	143
75P	K-2N-FRV-8 K-3N-FRV-8	75-80-90 100	640	194	459 474	271	110	156	110	164	SCF K-2N-FRV-8 SCF K-3N-FRV-8	569 584	177	DCF K-2N-FRV-8 DCF K-3N-FRV-8	684 699	184
75P	K-2N-FRV-8x2 K-3N-FRV-8x2	75-80-90 100	640	246	511 526	271	110	156	110	174	SCF K-2N-FRV-8x2 SCF K-3N-FRV-8x2	621 636	187	DCF K-2N-FRV-8x2 DCF K-3N-FRV-8x2	736 751	194
80P	Available with flexible coupling <b>ROTOPIN AB</b> - See type "K-AB"										See type "SCF K-AB"			See type "DCF K-AB"		
85P																
90P																
95P																

\* Weight with oil - \*\* Reduced keyway - Standard bores in heavy type

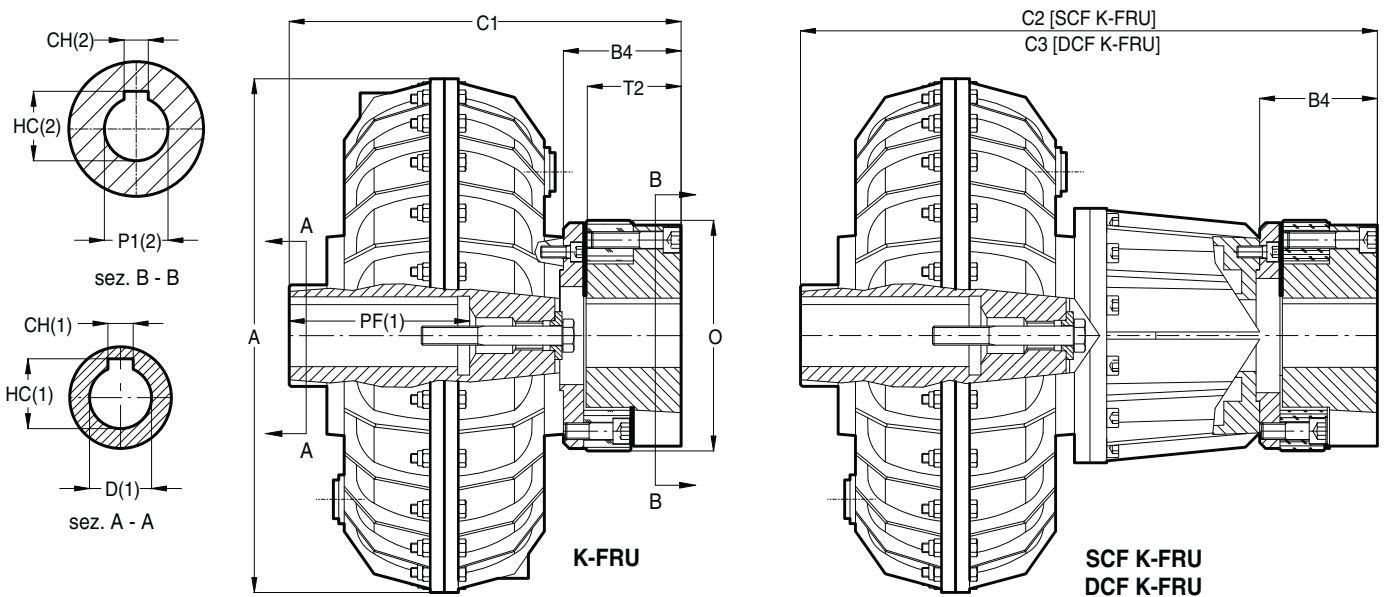

**The rubber element is not radially removable**

NOTE: (1) FOR BORE AND KEYWAY DIMENSIONS SEE SHEET 10-019D (2) UPON REQUEST: BORE P1 MACHINED SEE SHEET 10-023A

Size	K-FRU									SCF K-FRU			DCF K-FRU				
	Type	Dimensions mm.							Weight	Type	Dimensions mm.		Weight	Type	Dimensions mm.		Weight
		D	A	B4	C1	O	P1 Max.	T2	Kg *		C2	Kg. *		C3	Kg. *		
10	K-1-FRU-2	14-19-24	193	60	158	100	38	45	5,8	-	-	-	-	-	-	-	
	K-3-FRU-2	28															174
20	K-1-FRU-3	19-24-28	230	73	198	126	48	55	9,6	-	-	-	-	-	-	-	
	K-3-FRU-3	38															208
30	K-1-FRU-4	28-38-42	290	81	245	153	60	60	19,5	SCF K-2-FRU-4	300	21,9	DCF K-2-FRU-4	340	22,5	-	-
	K-3-FRU-4	48 **			273				19,5	SCF K-3-FRU-4	328	21,9	DCF K-3-FRU-4	368	22,5		
	K-4-FRU-4	55			302				20,5	SCF K-4-FRU-4	357	22,9	DCF K-4-FRU-4	397	23,5		
30P	K-1-FRU-4	28-38-42	327	81	245	153	60	60	27,3	SCF K-2-FRU-4	300	29,7	DCF K-2-FRU-4	340	30,3	-	-
	K-3-FRU-4	48 **			273				27,3	SCF K-3-FRU-4	328	29,7	DCF K-3-FRU-4	368	30,3		
	K-4-FRU-4	55			302				28,3	SCF K-4-FRU-4	357	30,7	DCF K-4-FRU-4	397	31,3		
40P	K-1-FRU-5	38-42-48-55	338	90	288	170	70	70	31	SCF K-2-FRU-5	346	34,7	DCF K-2-FRU-5	418	36,2	-	-
	K-2-FRU-5	60								309	346	34,7	DCF K-2-FRU-5	418	36,2		
50	K-2-FRU-6	42-48-55-60-65	430	99	278	190	80	80	42,5	SCF K-2-FRU-6	358	48,3	DCF K-2-FRU-6	433	50,5	-	-
	K-3-FRU-6	75								309	389	58,3	DCF K-3-FRU-6	464	60,5		
55	K-2-FRU-6	42-48-55-60-65	430	99	310	190	80	80	52,5	SCF K-2-FRU-6	390	58,3	DCF K-2-FRU-6	465	60,5	-	-
	K-3-FRU-6	75								309	389	58,3	DCF K-3-FRU-6	464	60,5		
60	K-2-FRU-7	48-55-60-65-75	520	118	310	232	100	90	69	SCF K-2-FRU-7	400	77,4	DCF K-2-FRU-7	480	81	-	-
	K-3-FRU-7	80								340	430	77,4	DCF K-3-FRU-7	510	81		
65	K-2-FRU-7	55-60-65-75-80	520	118	358	232	100	90	89	SCF K-2-FRU-7	448	97,4	DCF K-2-FRU-7	528	101	-	-
70P	K-2N-FRU-8	65-75-80-90	640	139	379	271	110	110	123	SCF K-2N-FRU-8	489	136	DCF K-2N-FRU-8	604	143	-	-
	K-3N-FRU-8	100								419	529	136	DCF K-3N-FRU-8	644	143		
75P	K-2N-FRU-8	75-80-90	640	139	404	271	110	110	164	SCF K-2N-FRU-8	514	177	DCF K-2N-FRU-8	629	184	-	-
	K-3N-FRU-8	100								419	529	177	DCF K-3N-FRU-8	644	184		
75P	K-2N-FRU-8x2	75-80-90	640	191	456	271	110	110	174	SCF K-2N-FRU-8x2	566	187	DCF K-2N-FRU-8x2	681	194	-	-
	K-3N-FRU-8x2	100								471	581	187	DCF K-3N-FRU-8x2	696	194		
80P	Available with flexible coupling ROTOPIN AB - See type "K-AB"									See type "SCF K-AB"			See type "DCF K-AB"				
85P																	
90P																	
95P																	

\* Weight with oil - \*\* Reduced keyway - Standard bores in heavy type



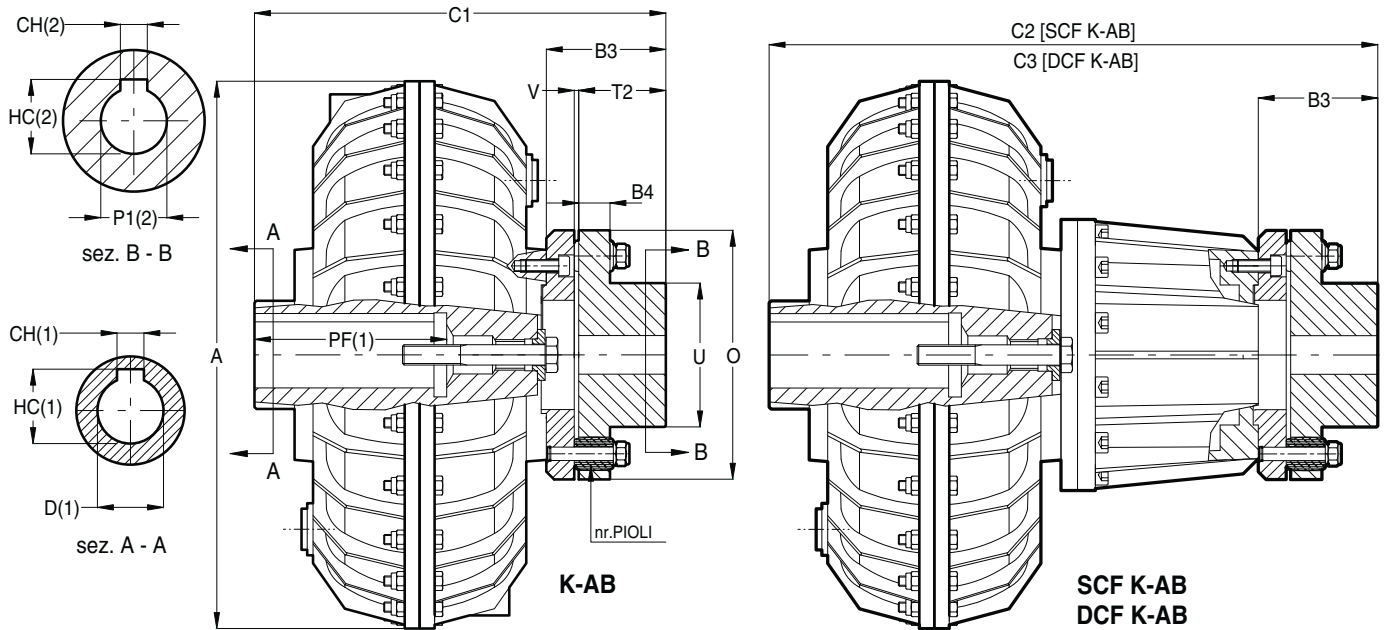

NOTE: (1) FOR BORE AND KEYWAY DIMENSIONS SEE SHEET 10-019D (2) UPON REQUEST: BORE P1 MACHINED SEE SHEET 10-023A

Size	K-AB												SCF K-AB			DCF K-AB			
	Dimensions mm.											Weight Kg *	Dimensions mm.		Weight Kg *	Dimensions mm.		Weight Kg *	
	D	A	B3	B4	C1	nr.	O	P1 Max.	T2	U	V		Type	C2		Type	C3		
80P	K-2N-AB-8	max. 110	810	196	65	466	8	330	110	140	170	6	240	SCF K-2N-AB-8	584	256	DCF K-2N-AB-8	684	268
	K-3N-AB-8	max. 125***												SCF K-3N-AB-8	600		DCF K-3N-AB-8	700	
85P	K-2N-AB-8M	max. 125	810	226	65	566	12	400	155	170	236	6	367	SCF K-2N-AB-8M	684	383	DCF K-2N-AB-8M	784	395
	K-3N-AB-8M	max. 135												SCF K-3N-AB-8M	684		DCF K-3N-AB-8M	784	
90P	K-2-AB-9	max. 130	1000	318	82	682	14	550	180	250	290	6	600	SCF K-2-AB-9	742	640	DCF K-2-AB-9	822	655
	K-3-AB-9	max. 140***												SCF K-3-AB-9	842		DCF K-3-AB-9	922	
95P	K-2-AB-9	max. 130	1000	318	82	797	14	550	180	250	290	6	755	SCF K-2-AB-9	917	795	DCF K-2-AB-9	997	810
	K-3-AB-9	max. 140***												SCF K-3-AB-9	1024		DCF K-3-AB-9	1104	
1200	K-2-AB-9	max. 190	1300	318	82	780	14	550	180	250	290	6	2050	-	-	-	-	-	-

\* Weight with oil - \*\*\* Depth of bore PF = 210 (for larger bores consult WESTCAR)

For “REVERSE MOUNTING” see type “KK”

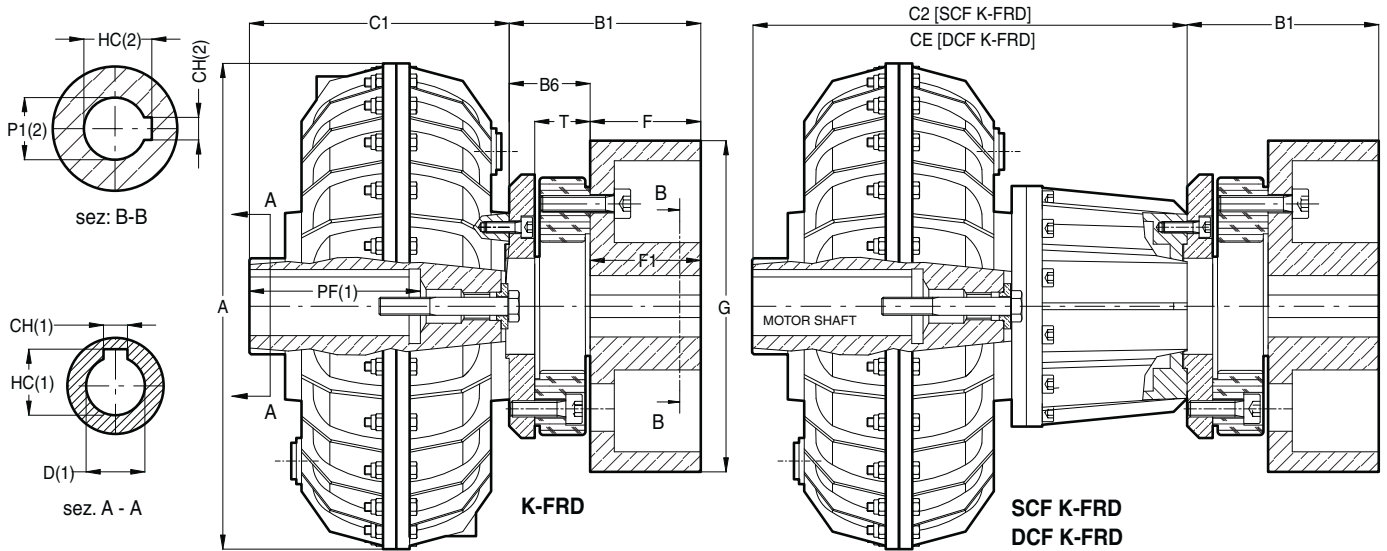

NOTE: (1) FOR BORE AND KEYWAY DIMENSIONS SEE SHEET 10-019D

(2) UPON REQUEST: BORE P1 MACHINED SEE SHEET 10-023A

Size	K-FRD								SCF K-FRD			DCF K-FRD		
	Dimensions mm							Weight Kg.*	Dimensions mm		Weight Kg.*	Dimensions mm		Weight Kg.*
	Type	D	A	B6	C1	P1 Max.	T		Type	C2		Type	C3	
20	K-1-FRD-3 K-3-FRD-3	19-24-28 38	230	43	125 135	48	28	7,6	-	-	-	-	-	
30	K-1-FRD-4 K-3-FRD-4 K-4-FRD-4	28-38-42 48 ** 55	290	51	162 190 219	60	34	15,8	SCF K-2-FRD-4 SCF K-3-FRD-4 SCF K-4-FRD-4	217 245 274	18,2	DCF K-2-FRD-4 DCF K-3-FRD-4 DCF K-4-FRD-4	257 285 314	18,8
30P	K-1-FRD-4 K-3-FRD-4 K-4-FRD-4	28-38-42 48 ** 55	327	51	162 190 219	60	34	23,6	SCF K-2-FRD-4 SCF K-3-FRD-4 SCF K-4-FRD-4	217 245 274	26	DCF K-2-FRD-4 DCF K-3-FRD-4 DCF K-4-FRD-4	257 285 314	26,6
40P	K-1-FRD-5 K-2-FRD-5	38-42-48-55 60	338	55	198	70	38	25,3	SCF K-2-FRD-5 SCF K-2-FRD-5	256 256	29	DCF K-2-FRD-5 DCF K-2-FRD-5	328	30,5
50	K-2-FRD-6	42-48-55-60-65	430	59	179	80	42	34	SCF K-2-FRD-6	259	39,8	DCF K-2-FRD-6	334	42
55	K-2-FRD-6 K-3-FRD-6	42-48-55-60-65 75	430	59	211 210	80	42	44	SCF K-2-FRD-5 SCF K-3-FRD-6	291 290	49,8	DCF K-2-FRD-6 DCF K-3-FRD-6	366 365	52
60	K-2-FRD-7 K-3-FRD-7	48-55-60-65-75 80	520	73	192 222	100	48	54,9	SCF K-2-FRD-7 SCF K-3-FRD-7	282 312	63,3	DCF K-2-FRD-7 DCF K-3-FRD-7	362 392	66,9
65	K-2-FRD-7	55-60-65-75-80	520	73	240	100	48	74,9	SCF K-2-FRD-7	330	83,3	DCF K-2-FRD-7	410	86,9
70P	K-2N-FRD-8 K-3N-FRD-8	65-75-80-90 100	640	84	240 280	110	56	91	SCF K-2N-FRD-8 SCF K-3N-FRD-8	350 390	114	DCF K-2N-FRD-8 DCF K-3N-FRD-8	465 505	121
75P	K-2N-FRD-8 K-3N-FRD-8	75-80-90 100	640	84	265 280	110	56	142	SCF K-2N-FRD-8 SCF K-3N-FRD-8	375 390	155	DCF K-2N-FRD-8 DCF K-3N-FRD-8	490 505	162
75P	K-2N-FRD-8x2 K-3N-FRD-8x2	75-80-90 100	640	136	317 332	110	56	152	SCF K-2N-FRD-8x2 SCF K-3N-FRD-8x2	427 442	165	DCF K-2N-FRD-8x2 DCF K-3N-FRD-8x2	542 557	172
80P	Available with flexible coupling <b>ROTOPIN AB</b> - See type “K-AFF”								See type “SCF K-AFF”			See type “DCF K-AFF”		
85P														
90P														
95P														

**BRAKE DRUMS “D” DIMENSIONS**

Size	D-3				D-4				D-5				D-6				D-7				D-8			
B1	103	118	138	161	126	146	169	130	150	173	205	245	134	154	177	209	249	191	223	263	234	274		
Ø G	160	200	250	315	200	250	315	200	250	315	400	500	200	250	315	400	500	315	400	500	400	500		
F=F1	60	75	95	118	75	95	118	75	95	118	150	190	75	95	118	150	190	118	150	190	150	190		
Kg.	4,7	7,2	13,1	22,8	8,6	14,8	25	9,3	15,8	26,2	45,1	76,2	10,8	17,8	28,7	48,4	80,5	32,6	53,5	87	55,7	90		

\* Weight with oil without Brake Drum - \*\* Reduced keyway - Standard bores in **heavy** type

For “REVERSE MOUNTING” see type “KK”

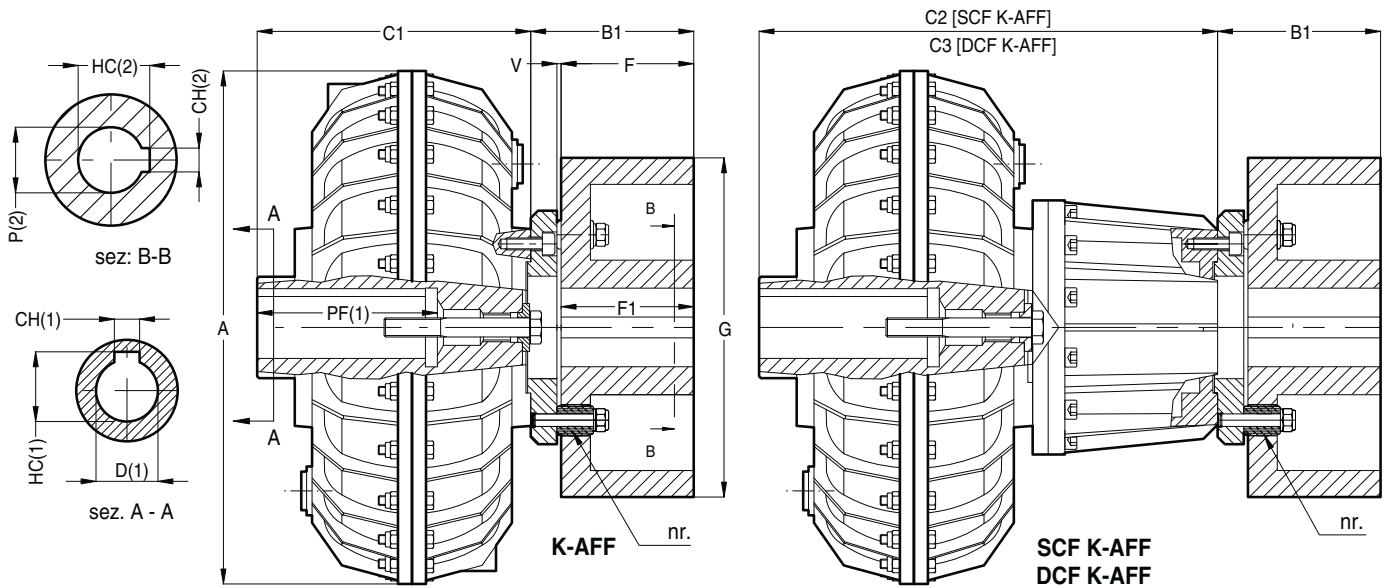

NOTE: (1) FOR BORE AND KEYWAY DIMENSIONS SEE SHEET 10-019D

(2) UPON REQUEST: BORE P1 MACHINED SEE SHEET 10-023A

Size	K-AFF								SCF K-AFF			DCF K-AFF		
	Dimensions mm							Weight Kg *	Dimensions mm		Weight Kg *	Dimensions mm		Weight Kg *
	Type	D	A	C1	nr.	P1 Max.	V		Type	C2		Type	C3	
50	K-2-AFF-5	42-48-55-60-65	430	179	8	70	4	35	SCF K-2-AFF-5	259	40,8	DCF K-2-AFF-5	334	43
55	K-2-AFF-5	42-48-55-60-65	430	211	8	70	4	45	SCF K-2-AFF-5	291	50,8	DCF K-2-AFF-5	366	53
	K-3-AFF-5	75	210	8	70	4	45	SCF K-3-AFF-5	290	50,8	DCF K-3-AFF-5	365	53	
60	K-2-AFF-6	48-55-60-65-75	520	192	8	85	4	54	SCF K-2-AFF-6	282	62,4	DCF K-2-AFF-6	362	66
	K-3-AFF-6	80	222	8	85	4	54	SCF K-3-AFF-6	312	62,4	DCF K-3-AFF-6	392	66	
65	K-2-AFF-6	55-60-65-75-80	520	240	8	85	4	74	SCF K-2-AFF-6	330	82,4	DCF K-2-AFF-6	410	86
70P	K-2N-AFF-8/7	75-80-90	640	240	8	105	5	101	SCF K-2N-AFF-7	350	114	DCF K-2N-AFF-7	465	121
	K-3N-AFF-8/7	100	280	8	105	5	101	SCF K-3N-AFF-7	390	114	DCF K-3N-AFF-7	505	121	
75P	K-2N-AFF-8/7	80-90	640	265	8	105	5	142	SCF K-2N-AFF-7	375	155	DCF K-2N-AFF-7	490	162
	K-3N-AFF-8/7	100	280	8	105	5	142	SCF K-3N-AFF-7	390	155	DCF K-3N-AFF-7	505	162	
80P	K-2N-AFF-8	max. 110	810	270	8	110	6	210	SCF K-2N-AFF-8	388	226	DCF K-2N-AFF-8	488	238
	K-3N-AFF-8	max. 125***	286	8	110	6	210	SCF K-3N-AFF-8	404	226	DCF K-3N-AFF-8	504	238	
85P	K-2N-AFF-8M	max. 125	810	340	12	160	6	302	SCF K-2N-AFF-8M	458	318	DCF K-2N-AFF-8M	558	330
	K-3N-AFF-8M	max. 135	340	12	160	6	302	SCF K-3N-AFF-8M	458	318	DCF K-3N-AFF-8M	558	330	
90P	K-2-AFF-9	max. 130	1000	364	14	180	6	450	SCF K-2-AFF-9	424	490	DCF K-2-AFF-9	504	505
	K-3-AFF-9	max. 140***	764	14	180	6	450	SCF K-3-AFF-9	524	490	DCF K-3-AFF-9	604	545	
95P	K-2-AFF-9	max. 130	1000	479	14	180	6	605	SCF K-2-AFF-9	599	645	DCF K-2-AFF-9	679	660
	K-3-AFF-9	max. 140***	586	14	180	6	605	SCF K-3-AFF-9	706	645	DCF K-3-AFF-9	786	710	

**BRAKE DRUMS “D” DIMENSIONS**

Size	FF-5			FF-6			FF-8/7 FF-8			FF-8M			FF-9		
B1	124	147	179	156	188	228	206	246	292	206	246	292	255	304	333
Ø G	250	315	400	315	400	500	400	500	630	400	500	630	500	630	710
F=F1	95	118	150	118	150	190	150	190	236	150	190	236	190	236	265
Kg.	20	33	50	38	56	89	75	108	168	85	118	178	236	296	365

\* Weight with oil - \*\* Reduced keyway - \*\*\* Depth of bore PF = 210 (for larger bores consult WESTCAR) - Standard bores in heavy type

For “REVERSE MOUNTING” see type “KK”

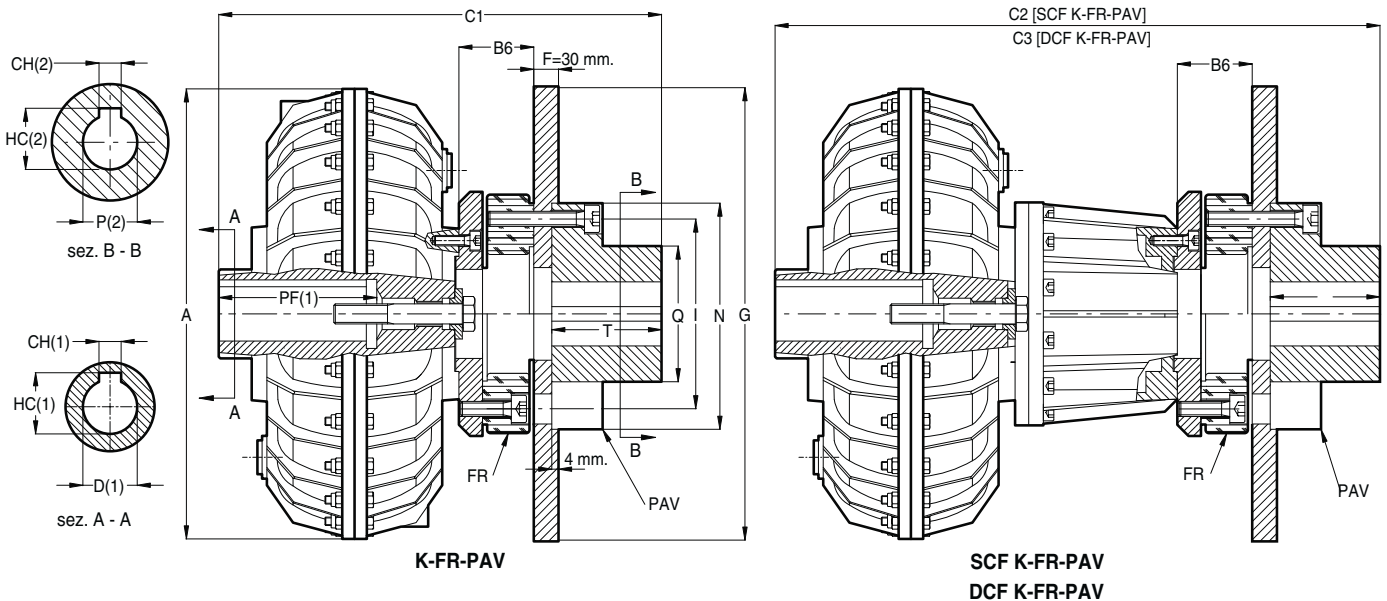

NOTE: (1) FOR BORE AND KEYWAY DIMENSIONS SEE SHEET 10-019D (2) UPON REQUEST: BORE P1 MACHINED SEE SHEET 10-023A

Size	K-FR-PAV											SCF K-FR-PAV			DCF K-FR-PAV			
	Dimensions mm											Weight Kg.*	Dimensions mm		Weight Kg.*	Dimensions mm		Weight Kg.*
	Type	D	A	B6	C1	P1 Max.	T	Q	I	N	Ø G		Type	C2		Type	C3	
10	K-1-FR-PAV-2 K-3-FR-PAV-2	14-19-24 28	193	35	204 220	38	45	55	78	94	200	5,8	-	-	-	-	-	
20	K-1-FR-PAV-3 K-3-FR-PAV-3	19-24-28 38	230	43	249 259	48	55	69	100	118	250-315	9,6	-	-	-	-	-	
30	K-1-FR-PAV-4 K-3-FR-PAV-4 K-4-FR-PAV-4	28-38-42 48** 55	290	51	299 327 356	60	60	91	125	145	250-315	19,5	SCF K-1-FR-PAV-4 SCF K-3-FR-PAV-4 SCF K-4-FR-PAV-4	354 382 411	21,9	DCF K-1-FR-PAV-4 DCF K-3-FR-PAV-4 DCF K-4-FR-PAV-4	394 422 451	
30P	K-1-FR-PAV-4 K-3-FR-PAV-4 K-4-FR-PAV-4	28-38-42 48** 55	327	51	299 327 356	60	60	91	125	145	250-315	27,3	SCF K-1-FR-PAV-4 SCF K-3-FR-PAV-4 SCF K-4-FR-PAV-4	354 382 411	29,7	DCF K-1-FR-PAV-4 DCF K-3-FR-PAV-4 DCF K-4-FR-PAV-4	394 422 451	
40P	K-1-FR-PAV-5 K-2-FR-PAV-5	42-48-55 60	338	55	349	70	70	106	140	165	315-355-400	31	SCF K-2-FR-PAV-5	407	34,7	DCF K-2-FR-PAV-5	479	36,2
50	K-2-FR-PAV-6	42-48- 55-60-65	430	59	344	80	80	121	160	185	315-355-400	42,5	SCF K-2-FR-PAV-6	424	48,3	DCF K-2-FR-PAV-6	499	50,5
55	K-2-FR-PAV-6 K-3-FR-PAV-6	55-60-65- 75	430	59	376 375	80	80	121	160	185	315-355-400	52,5	SCF K-2-FR-PAV-6 SCF K-3-FR-PAV-6	456 455	58,3	DCF K-2-FR-PAV-6 DCF K-3-FR-PAV-6	531 530	60,5
60	K-2-FR-PAV-7 K-3-FR-PAV-7	60-65-75- 80	520	73	381 411	100	90	146	195	225	400-450-500	69	SCF K-2-FR-PAV-7 SCF K-3-FR-PAV-7	471 501	77,4	DCF K-2-FR-PAV-7 DCF K-3-FR-PAV-7	551 581	81
65	K-2-FR-PAV-7	55-60- 65-75-80	520	73	429	100	90	146	195	225	400-450-500	89	SCF K-2N-FR-PAV-7	519	97,4	DCF K-2N-FR-PAV-7	599	101
70P	K-2N-FR-PAV-8 K-3N-FR-PAV-8	75-80-90 100	640	84	460 500	110	110	156	225	270	500-560-630	123	SCF K-2N-FR-PAV-8 SCF K-3N-FR-PAV-8	570 610	136	DCF K-2N-FR-PAV-8 DCF K-3N-FR-PAV-8	685 725	143
75P	K-2N-FR-PAV-8 K-3N-FR-PAV-8	75-80-90 100	640	84	485 500	110	110	156	225	270	500-560-630 710	164	SCF K-2N-FR-PAV-8 SCF K-3N-FR-PAV-8	595 610	177	DCF K-2N-FR-PAV-8 DCF K-3N-FR-PAV-8	710 725	184
75P	K-2N-FR-PAV-8x2 K-3N-FR-PAV-8x2	75-80-90 100	640	136	537 552	110	110	156	225	270	500-560-630 710	174	SCF K-2N-FR-PAV-8x2 SCF K-3N-FR-PAV-8x2	647 662	187	DCF K-2N-FR-PAV-8x2 DCF K-3N-FR-PAV-8x2	762 777	194

**BRAKE DISC “PA”**

Ø G	200	250	315	355	400	450	500	560	630	710
F	30	30	30	30	30	30	30	30	30	30
Weight Kg.	3,7	5,7	9,1	12,5	14,7	18	23	28	36	45

Different disc thickness “F” is available on request – \* Weight with oil without brake disc “PA” – \*\* Reduced keyway – Standard bores in heavy type

REVERSE ASSEMBLY

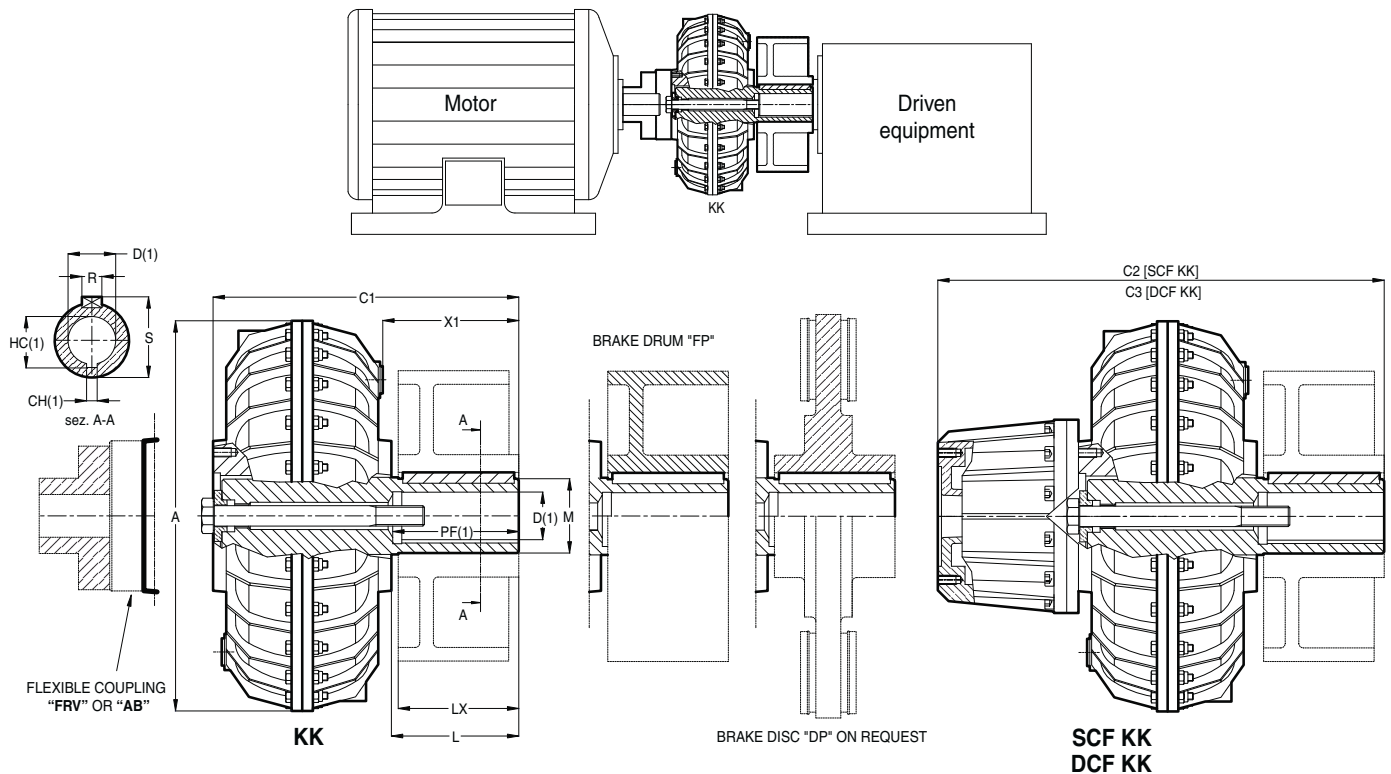

NOTE: (1) FOR BORE AND KEYWAY DIMENSIONS SEE SHEET 10-019D

Size	KK											SCF KK			DCF KK		
	Type	D Max.	A	C1	L	LX	M	R	S	X1	Weight Kg.*	Type	C2	Weight Kg.*	Type	C3	Weight Kg.*
20	K-2 K 70	28	230	185	70	60	44	10	47,3	77	6,2	..	--	--	--	--	--
30	K-2 K 68	42	290	218	68	60	57	12	60,3	77	13,6	SCF K-2 K 68	273	16	DCF K-2 K 68	313	16,6
	K-2 K 88			238	88	75				97	13,8	SCF K-2 K 88	293	16,2	DCF K-2 K 88	333	16,8
	K-2 K 112			262	112	95				121	14	SCF K-2 K 112	317	16,4	DCF K-2 K 112	356	17
30P	K-2 K 68	42	327	218	68	60	57	12	60,3	77	21,4	SCF K-2 K 68	273	23,8	DCF K-2 K 68	313	24,4
	K-2 K 88			238	88	75				97	21,6	SCF K-2 K 88	293	24	DCF K-2 K 88	333	24,6
	K-2 K 112			262	112	95				121	21,8	SCF K-2 K 112	317	24,2	DCF K-2 K 112	356	24,8
40P	K-2 K 90	60	338	273	90	75	77	16	81,3	114	23	SCF K-2 K 90	331	26,7	DCF K-2 K 90	403	28,2
	K-2 K 118			301	118	115				142	23,5	SCF K-2 K 118	359	27,2	DCF K-2 K 118	431	28,7
50	K-2 K 90	65	430	234	90	86	85	18	89,3	97	32,5	SCF K-2 K 90	314	38,3	DCF K-2 K 90	389	40,5
	K-2 K 120			264	120	118				127	33,5	SCF K-2 K 120	344	39,3	DCF K-2 K 120	419	41,5
	K-2 K 155			299	155	150				162	34,5	SCF K-2 K 155	379	40,3	DCF K-2 K 155	454	42,5
55	K-2 K 90	65	430	286	90	86	85	18	89,3	97	42	SCF K-2 K 90	366	47,8	DCF K-2 K 90	441	50
	K-2 K 120			316	120	118				127	43	SCF K-2 K 120	396	48,8	DCF K-2 K 120	471	51
	K-2 K 155			351	155	150				162	44	SCF K-2 K 155	431	49,8	DCF K-2 K 155	506	52
60	K-2 K 130	80	520	302	130	118	107	20	111,9	136	50	SCF K-2 K 130	392	58,4	DCF K-2 K 130	472	62
	K-2 K 170			342	170	150				176	53	SCF K-2 K 170	432	61,4	DCF K-2 K 170	512	65
	K-2 K 230			402	230	190				236	56	SCF K-2 K 230	492	64,4	DCF K-2 K 230	572	68
65	K-2 K 130	80	520	350	130	118	107	20	111,9	136	69	SCF K-2 K 130	440	77,4	DCF K-2 K 130	520	71
	K-2 K 170			390	170	150				176	72	SCF K-2 K 170	480	80,4	DCF K-2 K 170	560	74
	K-2 K 220			440	220	190				226	76	SCF K-2 K 220	530	84,4	DCF K-2 K 220	610	78
	K-2 K 255			475	255	236				261	79	SCF K-2 K 255	565	87,4	DCF K-2 K 255	645	81

\* Weight with oil



REVERSE ASSEMBLY

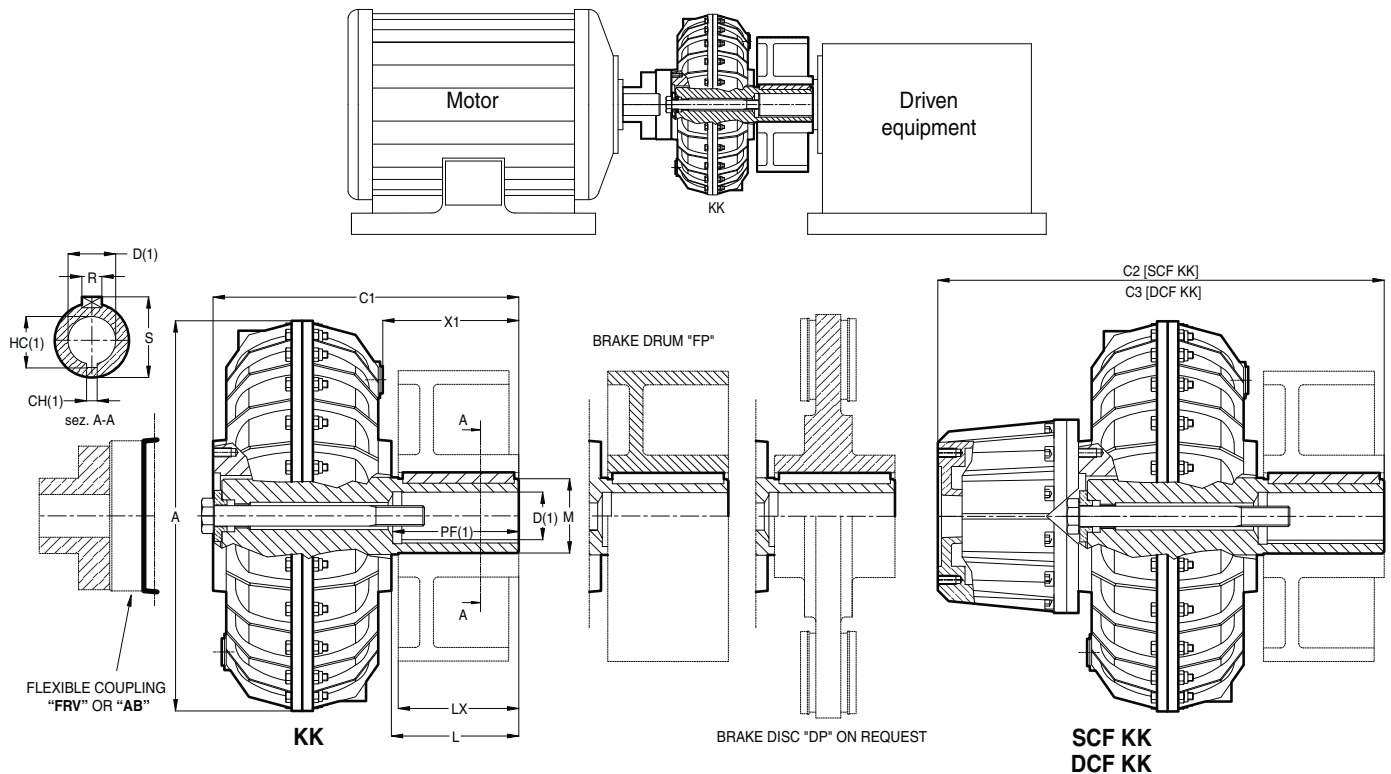

NOTE: (1) FOR BORE AND KEYWAY DIMENSIONS SEE SHEET 10-019D

Size	KK										SCF KK			DCF KK			
	Dimensions mm										Weight	Dimensions mm		Weight	Dimensions mm		Weight
	Type	D Max.	A	C1	L	LX	M	R	S	X1	Kg. *	Type	C2	Kg. *	Type	C3	Kg. *
70P	K-2N K 155	90	640	345	155	150	128	25	133,4	159	105	SCF K-2N K 155	455	118	DCF K-2N K 155	570	125
	K-2N K 195			385	195	190				199	108	SCF K-2N K 195	495	121	DCF K-2N K 195	610	128
	K-2N K 240			430	240	236				244	112	SCF K-2N K 240	540	125	DCF K-2N K 240	655	132
	K-2N K 270			460	270	265				274	115	SCF K-2N K 270	570	128	DCF K-2N K 270	685	135
	K-2N K 305			495	305	300				309	118	SCF K-2N K 305	605	131	DCF K-2N K 305	720	138
75P	K-2N K 155	90	640	400	155	150	128	25	133,4	159	130	SCF K-2N K 155	510	143	DCF K-2N K 155	625	150
	K-2N K 195			440	195	190				199	134	SCF K-2N K 195	550	147	DCF K-2N K 195	665	154
	K-2N K 240			485	240	236				244	139	SCF K-2N K 240	595	152	DCF K-2N K 240	710	159
	K-2N K 270			515	270	265				274	141	SCF K-2N K 270	625	154	DCF K-2N K 270	740	161
	K-2N K 305			550	305	300				309	145	SCF K-2N K 305	660	158	DCF K-2N K 305	775	165
80P	K-2N K 195	125	810	421	195	190	160	28	166,4	193	190	SCF K-2N K 195	539	206	DCF K-2N K 195	639	218
	K-2N K 240			466	240	236				238	200	SCF K-2N K 240	584	216	DCF K-2N K 240	684	228
	K-2N K 270			496	270	265				268	208	SCF K-2N K 270	614	224	DCF K-2N K 270	714	236
	K-2N K 305			531	305	300				303	215	SCF K-2N K 305	649	231	DCF K-2N K 305	749	243
85P	K-2N K 195	125	810	495	195	190	160	28	166,4	193	260	SCF K-2N K 195	613	276	DCF K-2N K 195	713	288
	K-2N K 240			540	240	236				270	270	SCF K-2N K 240	658	286	DCF K-2N K 240	758	298
	K-2N K 270			570	270	265				268	278	SCF K-2N K 270	688	294	DCF K-2N K 270	788	306
	K-2N K 305			605	305	300				303	285	SCF K-2N K 305	723	301	DCF K-2N K 305	823	313
90P	K-2 K 240	135	1000	584	240	236	170	32	177,4	240	370	SCF K-2 K 240	604	410	DCF K-2 K 240	784	525
	K-2 K 270			614	270	265				270	380	SCF K-2 K 270	634	420	DCF K-2 K 270	814	535
	K-2 K 305			649	305	300				305	390	SCF K-2 K 305	669	430	DCF K-2 K 305	849	545
95P	K-2 K 240	135	1000	706	240	236	170	32	177,4	240	520	SCF K-2 K 240	826	560	DCF K-2 K 240	906	575
	K-2 K 270			736	270	265				270	530	SCF K-2 K 270	856	570	DCF K-2 K 270	936	585
	K-2 K 305			771	305	300				305	540	SCF K-2 K 305	891	580	DCF K-2 K 305	971	595

\* Weight with oil



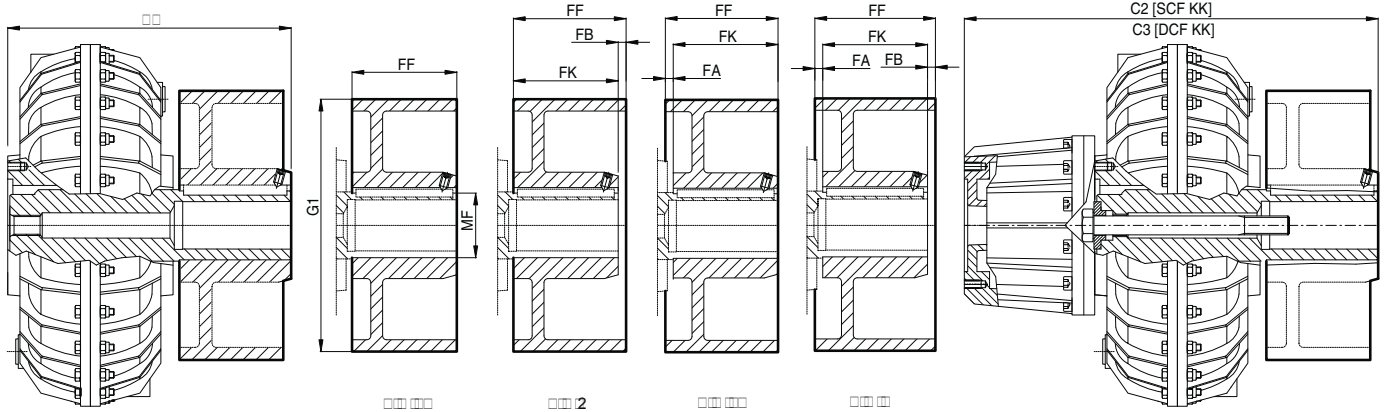

20 0 0 0 0 0 0 60 6

KK		SCF KK		DCF KK											
Size	Type	C1	Type	C2	Type	C3	Drum "FP"	Fig.	G1	FF	MF <sub>H7</sub>	FK	FA	FB	Kg.*
20	2070						FP-44-160		60	60		60	0	0	
	2070						FP-44-200		200	70		60			70
30	2060	200	2060	270	2060		FP-57-160		60	60		60	0	0	6
	2000	200	2000	200	2000		FP-57-200		200	70	70	70	0	0	
	2002	262	2002	007	2002	007	FP-57-250		200				0	0	
30P	2060	200	2060	270	2060		FP-57-160		60	60		60	0	0	6
	2000	200	2000	200	2000		FP-57-200		200	70	70	70	0	0	
	2002	262	2002	007	2002	007	FP-57-250		200				0	0	
40P	2000	270	2000		2000	000	FP-77-200		200	70		70	0	0	
	2000	270	2000		2000	000	FP-77-250		200		77	70	20	0	6
	2000	000	2000		2000		FP-77-315						0	0	20
	2000	000	2000		2000		FP-77-400		000	000			20	0	
50	2000	200	2000	020	2000		FP-85-250		200			60	0	0	70
	2020	260	2020		2020		FP-85-315						0	0	20
	2000	200	2000		2000		FP-85-400		000	000		000	0	0	
55	2000	206	2000	066	2000		FP-85-250		200			60	0	0	70
	2020	006	2020	006	2020	007	FP-85-315						0	0	20
	2000		2000		2000	006	FP-85-400		000	000		000	0	0	
60	2000	002	2000	002	2000	002	FP-107-315						0	0	20
	2070	002	2070	002	2070	002	FP-107-400		000	000	007	000	0	0	00
	2020	002	2020	002	2020	002	FP-107-500		000	000		000	0	0	00
65	2000	000	2000	000	2000	020	FP-107-315						0	0	20
	2070	000	2070	000	2070	060	FP-107-400		000	000		000	0	0	00
	20220	000	20220	000	20220	600	FP-107-500		000	000	007	000	0	0	00
	20200	007	20200	006	20200	600	FP-107-630		600	206		206	0	0	
	20200	007	20200	006	20200	600	FP-107-710		700	260		206	22	7	000

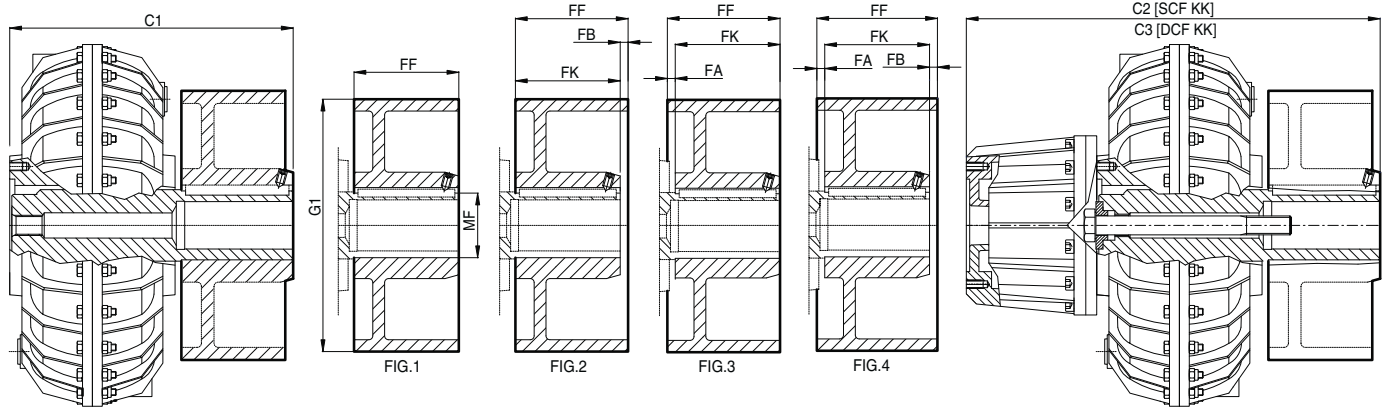

Coupling size 70P-75P-80P-85P-90P-95P

KK		SCF KK		DCF KK		Dimensions mm								Weight	
Size	Type	C1	Type	C2	Type	C3	Drum "FP"	Fig.	G1	FF	MF H7	FK	FA	FB	Kg.*
70P	K-2N K 155	345	SCF K-2N K 155	455	DCF K-2N K 155	570	<b>FP-128-400</b>	1	400	150	128	150	0	0	73
	K-2N K 195	385	SCF K-2N K 195	495	DCF K-2N K 195	610	<b>FP-128-500</b>		500	190		190	0	0	110
	K-2N K 240	430	SCF K-2N K 240	540	DCF K-2N K 240	655	<b>FP-128-630</b>		630	236		236	0	0	171
	K-2N K 270	460	SCF K-2N K 270	570	DCF K-2N K 270	685	<b>FP-128-710</b>		710	265		265	0	0	335
	K-2N K 305	495	SCF K-2N K 305	605	DCF K-2N K 305	720	<b>FP-128-800</b>		800	300		300	0	0	478
75P	K-2N K 155	400	SCF K-2N K 155	510	DCF K-2N K 155	625	<b>FP-128-400</b>	1	400	150	128	150	0	0	73
	K-2N K 195	440	SCF K-2N K 195	550	DCF K-2N K 195	665	<b>FP-128-500</b>		500	190		190	0	0	110
	K-2N K 240	485	SCF K-2N K 240	595	DCF K-2N K 240	710	<b>FP-128-630</b>		630	236		236	0	0	171
	K-2N K 270	515	SCF K-2N K 270	625	DCF K-2N K 270	740	<b>FP-128-710</b>		710	265		265	0	0	335
	K-2N K 305	550	SCF K-2N K 305	690	DCF K-2N K 305	775	<b>FP-128-800</b>		800	300		300	0	0	478
80P	K-2N K 195	421	SCF K-2N K 195	539	DCF K-2N K 195	639	<b>FP-160-500</b>	1	500	190	160	190	0	0	118
	K-2N K 240	466	SCF K-2N K 240	584	DCF K-2N K 240	684	<b>FP-160-630</b>		630	236		236	0	0	179
	K-2N K 270	496	SCF K-2N K 270	614	DCF K-2N K 270	714	<b>FP-160-710</b>		710	265		265	0	0	343
	K-2N K 305	531	SCF K-2N K 305	649	DCF K-2N K 305	749	<b>FP-160-800</b>		800	300		300	0	0	490
85P	K-2N K 195	495	SCF K-2N K 195	613	DCF K-2N K 195	713	<b>FP-160-500</b>	1	500	190	160	190	0	0	118
	K-2N K 240	540	SCF K-2N K 240	658	DCF K-2N K 240	758	<b>FP-160-630</b>		630	236		236	0	0	179
	K-2N K 270	570	SCF K-2N K 270	688	DCF K-2N K 270	788	<b>FP-160-710</b>		710	265		265	0	0	343
	K-2N K 305	605	SCF K-2N K 305	723	DCF K-2N K 305	823	<b>FP-160-800</b>		800	300		300	0	0	490
90P	K-2 K 240	584	SCF K-2 K 240	604	DCF K-2 K 240	784	<b>FP-170-630</b>	1	630	236	170	236	0	0	300
	K-2 K 270	614	SCF K-2 K 270	634	DCF K-2 K 270	814	<b>FP-170-710</b>		710	265		265	0	0	365
	K-2 K 305	649	SCF K-2 K 305	669	DCF K-2 K 305	849	<b>FP-170-800</b>		800	300		300	0	0	510
95P	K-2 K 240	706	SCF K-2 K 240	826	DCF K-2 K 240	906	<b>FP-170-630</b>	1	630	236	170	236	0	0	300
	K-2 K 270	736	SCF K-2 K 270	856	DCF K-2 K 270	936	<b>FP-170-710</b>		710	265		265	0	0	365
	K-2 K 305	771	SCF K-2 K 305	891	DCF K-2 K 305	971	<b>FP-170-800</b>		800	300		300	0	0	510

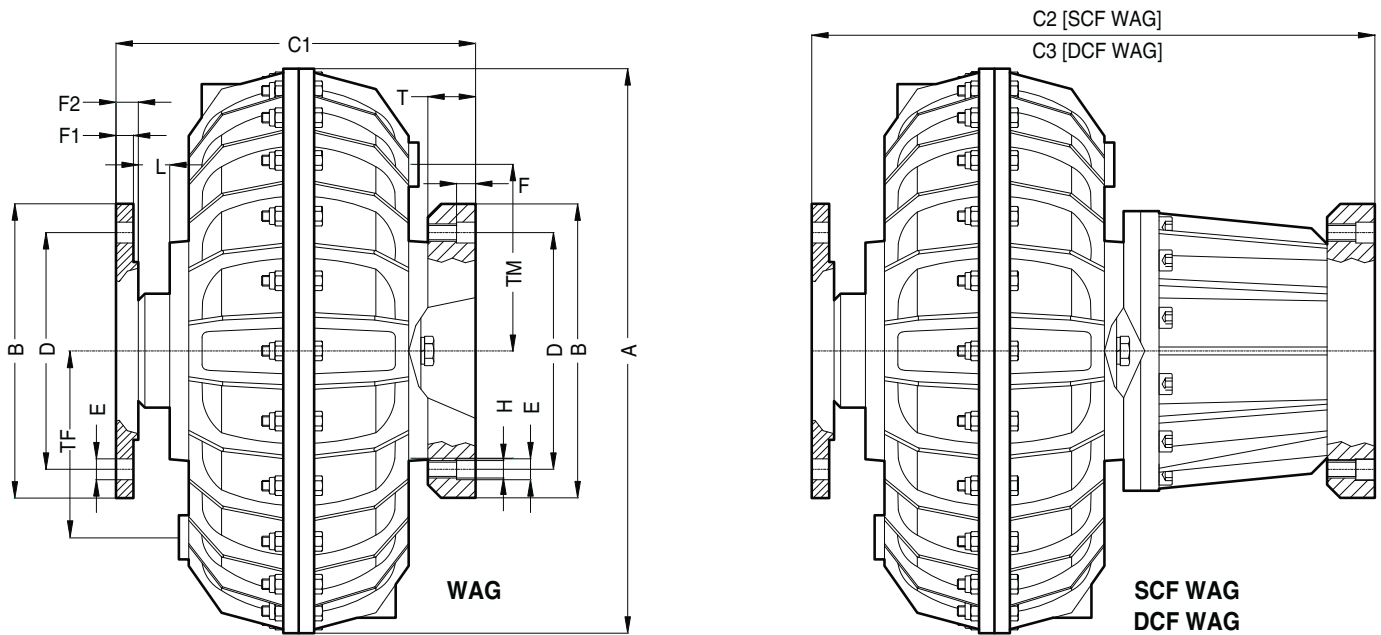

WAG																		
Size	Type	Basic Coupling	Dimensions mm														Gear Coupling	Weight Kg *
			A	B	C1	D	E		F	F1	F2	H	L	T	TF	TM		
							Nr	∅										
20	WAG	K-∅ 28	230	116	150	95,25	6	6,4	7	6,5	8	¼ 28 UNF	10	17	75	80	1" S	8,5
30	WAG	K-∅ 38	290	152,5	192,5	122,22	8	9,57	7	6,5	12	⅜ 24 UNF	12	18,5	110	110	1" ½ S	18,3
30P	WAG	K-∅ 38	327		192,5								130		130	26,3		
40P	WAG	K-∅ 48	338		231								15		21	130		130
50	WAG	K-∅ 55	430	212	25	150	150	36,2										
55	WAG	K-∅ 60	430	253	15	24,5	150	150	54,3									
60	WAG	K-∅ 75	520	235	20	25,5	205	192	61									
65	WAG	K-∅ 75	520	283	205	205	205	82,2										
70P	WAG	K-∅ 80	640	240	258,5	206,37	8	15,875	9,5	10	23	½ 20 UNF	20	25,5	265	265	3" E	102,7
75P	WAG	K-∅ 80	640		313,5													137,5
80P	WAG	K-∅ 90	810	280	355	241,3	8	19,05	22	28	35	¾ 10 UNF	44	50	325	325	3" ½ E	202
85P	WAG	K-∅ 90	810		425								286					
90P	WAG	K-∅ 110	1000	318	456	279,4	8	19,05	22	28	42	¾ 10 UNF	20	50	416	416	4" E	450

SCF WAG						DCF WAG					
Size	Type	Basic Coupling	Dimensions mm		Weight Kg *	Size	Type	Basic Coupling	Dimensions mm		Weight Kg *
			Gear Coupling	C2					Gear Coupling	C3	
30	SCF WAG	K-∅ 38	1" ½ S	247,5	20,7	30	DCF WAG	K-∅ 38	1" ½ S	287,5	21,3
30P	SCF WAG	K-∅ 38		247,5	28,5	30P	DCF WAG	K-∅ 38		287,5	29,1
40P	SCF WAG	K-∅ 48		289	35,9	40P	DCF WAG	K-∅ 48		361	33,4
50	SCF WAG	K-∅ 55	292	42	50	DCF WAG	K-∅ 55	367	44,2		
55	SCF WAG	K-∅ 60	2" ½ S	333	60	55	DCF WAG	K-∅ 60	2" ½ S	408	52,2
60	SCF WAG	K-∅ 75		325	69,4	60	DCF WAG	K-∅ 75		405	73
65	SCF WAG	K-∅ 75	373	90,6	65	DCF WAG	K-∅ 75	453	94,2		
70P	SCF WAG	K-∅ 80	3" E	368,5	115,7	70P	DCF WAG	K-∅ 80	3" E	483,5	122,7
75P	SCF WAG	K-∅ 80		423,5	150,5	75P	DCF WAG	K-∅ 80		538,5	157,7
80P	SCF WAG	K-∅ 90	3" ½ E	473	218	80P	DCF WAG	K-∅ 90	3" ½ E	573	232
85P	SCF WAG	K-∅ 90		543	302	85P	DCF WAG	K-∅ 90		643	314
90P	SCF WAG	K-∅ 110	4" E	576	490	90P	DCF WAG	K-∅ 110	4" E	656	505

\* Weight with oil

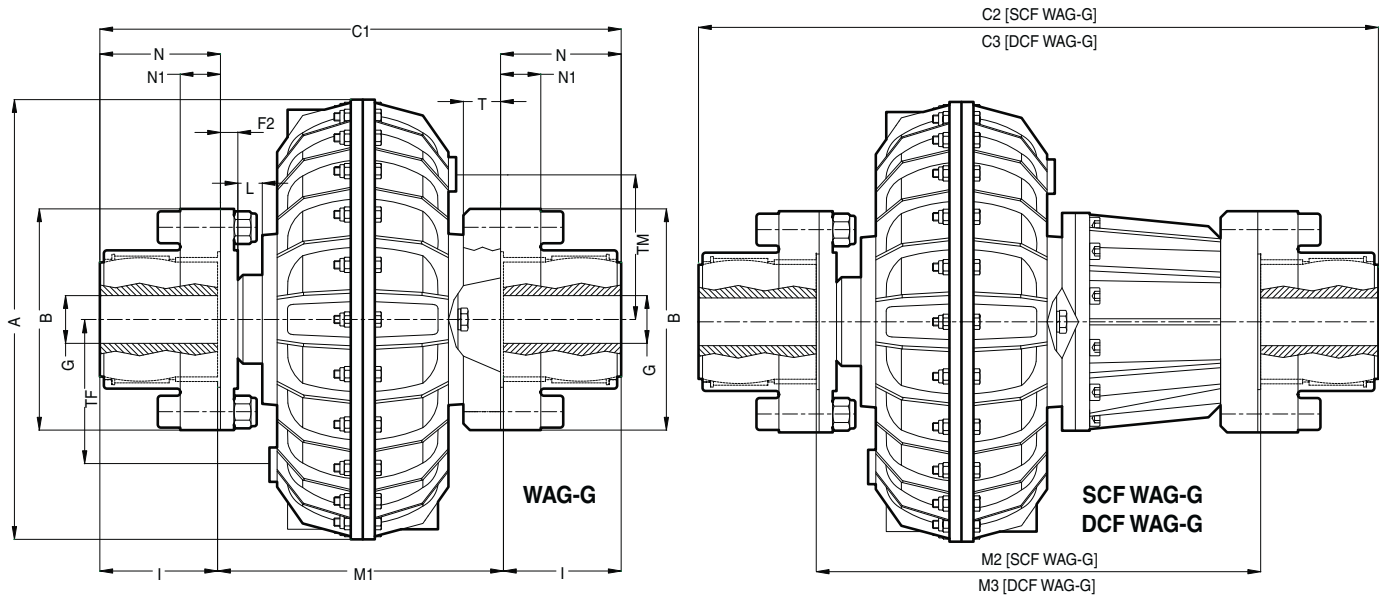

NOTE: For bore and keyway dimensions see sheet 10-023A

WAG-G																												
Size	Type	Basic Coupling	Dimensions mm														Weight Kg. *											
			A	B	C1	G		F2	I	L	M1	N	N1	T	TF	TM		Gear Coupling										
20	WAG-G	K1-Ø 28	230	111	240	raw	max	8	43	10	154	44,5	12	18	80	80	RE 40	13										
30	WAG-G	K1-Ø 38	290	142	297	15	60	12	50	12	197	51,5	10	20	110	110	RE 55	26,3										
30P	WAG-G	K1-Ø 38	327		297						197				130	130		34,1										
40P	WAG-G	K1-Ø 48	338		334						234				130	130		36,2										
50	WAG-G	K2-Ø 55	430	200	315	35	95	17,5	76	25	215	78,5	13	24,5	150	150	RE 85	44,2										
55	WAG-G	K2-Ø 60	430		410						15				258	150		150	79,3									
60	WAG-G	K2-Ø 75	520		392						35				95	17,5		76	20	240	78,5	13	25,5	205	192	205	RE 85	86
65	WAG-G	K2-Ø 75	520	225	440	45	110	23	90	20	288	92,5	13	30,5	265	265	RE 100	107,2										
70P	WAG-G	K2-Ø 80	640		448,5						110							23	90	20	268,5	92,5	13	30,5	265	265	RE 100	146,7
75P	WAG-G	K2-Ø 80	640		503,5						110							23	90	20	323,5	92,5	13	30,5	265	265	RE 100	187,5
80P	WAG-G	K2-Ø 90	810	265	548	55	130	28	105	44	338	108	22	34	325	325	RE 120	262										
85P	WAG-G	K2-Ø 90	810		618						130							28	105	40	408	108	22	34	325	325	RE 120	346
90P	WAG-G	K2-Ø 110	1000		748						130							28	105	20	448	154	24	34	416	416	RE 180	550
95P	WAG-G	K2-Ø 110	1000	370	863	90	190	42	150	13	563	154	24	34	416	416	RE 180	710										
1200	WAG-G	K2-Ø 160	1300		ON REQUEST																							

SCF WAG-G							DCF WAG-G						
Size	Type	Basic Coupling	Dimensions mm			Weight Kg. *	Size	Type	Basic Coupling	Dimensions mm			Weight Kg. *
			Gear Coupling	C2	M2					Gear Coupling	C3	M3	
30	SCF WAG-G	K1-Ø 38	RE 55	352	252	28,7	30	DCF WAG-G	K1-Ø 38	RE 55	392	292	29,3
30P	SCF WAG-G	K1-Ø 38		352	252	36,5	30P	DCF WAG-G	K1-Ø 38		392	292	37,1
40P	SCF WAG-G	K1-Ø 48		392	292	39,9	40P	DCF WAG-G	K1-Ø 48		464	364	41,2
50	SCF WAG-G	K2-Ø 55	RE 85	395	295	50	50	DCF WAG-G	K2-Ø 55	RE 85	470	370	52,2
55	SCF WAG-G	K2-Ø 60		490	338	85,1	55	DCF WAG-G	K2-Ø 60		565	413	87,2
60	SCF WAG-G	K2-Ø 75		482	330	94,4	60	DCF WAG-G	K2-Ø 75		562	410	98
65	SCF WAG-G	K2-Ø 75	RE 100	530	378	115,6	65	DCF WAG-G	K2-Ø 75	RE 100	610	458	119,2
70P	SCF WAG-G	K2-Ø 80		558,5	378,5	159,7	70P	DCF WAG-G	K2-Ø 80		673,5	493,5	166,7
75P	SCF WAG-G	K2-Ø 80		613,5	433,5	200,5	75P	DCF WAG-G	K2-Ø 80		728,5	548,5	207,5
80P	SCF WAG-G	K2-Ø 90	RE 120	666	456	278	80P	DCF WAG-G	K2-Ø 90	RE 120	766	556	290
85P	SCF WAG-G	K2-Ø 90		736	526	382	85P	DCF WAG-G	K2-Ø 90		836	626	374
90P	SCF WAG-G	K2-Ø 110		868	568	590	90P	DCF WAG-G	K2-Ø 110		949	648	605
95P	SCF WAG-G	K2-Ø 110	RE 180	983	683	750	95P	DCF WAG-G	K2-Ø 110	RE 180	1063	763	765

\* Weight with oil

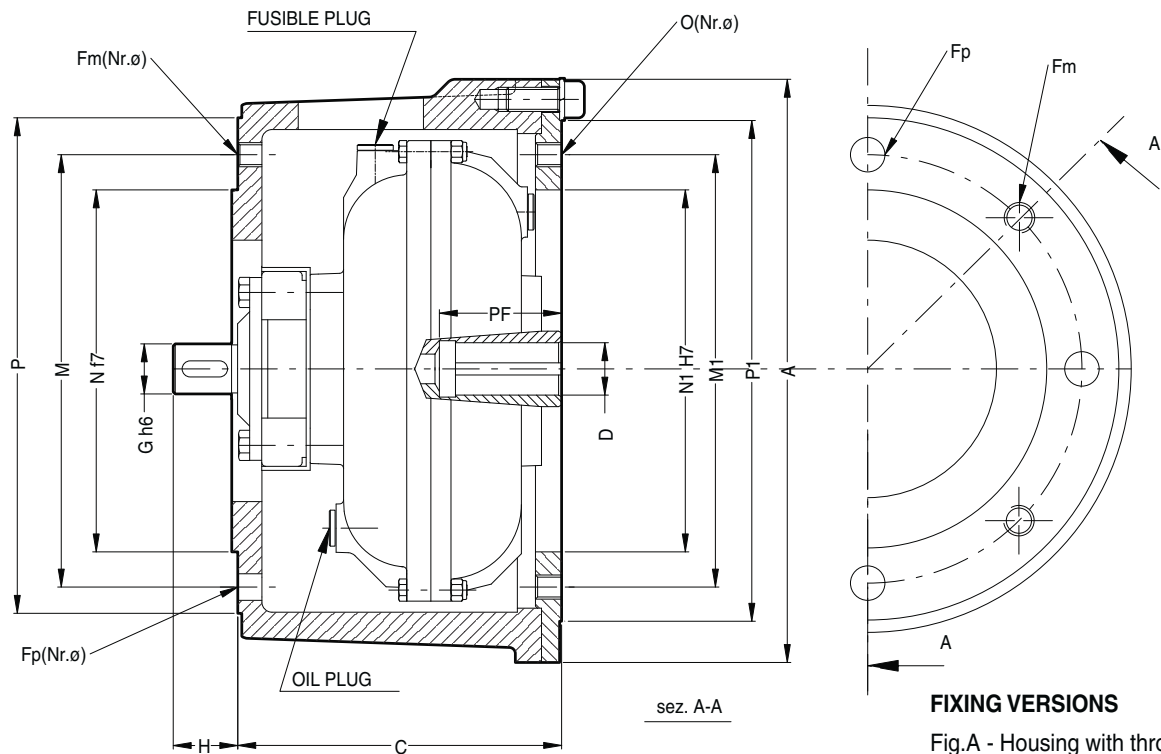

**FIXING VERSIONS**

Fig.A - Housing with through holes and gearbox with threaded holes

Fig.B - Housing with through holes and gearbox with through holes

Fig.C - Housing with threaded holes and gearbox with through holes

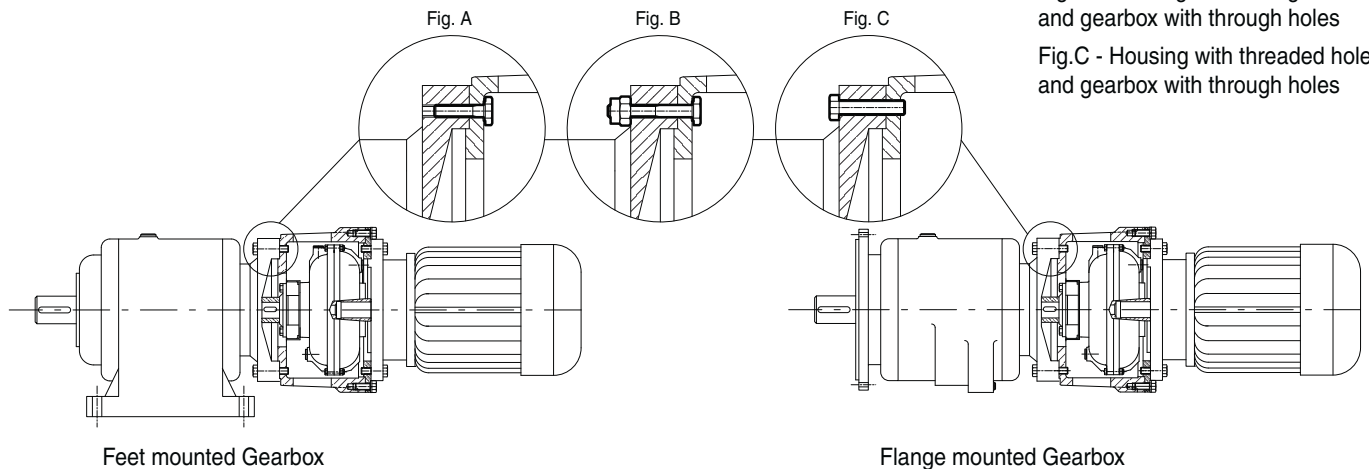

Feet mounted Gearbox

Flange mounted Gearbox

Coupling		Motor		Dimensions mm.														Weight		
Size	Type	Type	KW	A	C	D	Fm	Fp	G	H	M	M1	N (f7)	N1 (H7)	O	P	P1	PF	Kg.*	
10CK	19LRS19	80	0,55	240	128	19	Nr.4 M10	Nr.4 ø11	19	25	165	165	130	130	Nr.8 M10	200	200	45	8,5	
			0,75																	
10CK	24LRS24	90 S	1,1	240	128	24	Nr.4 M10	Nr.4 ø11	24	25	165	165	130	130	Nr.8 M10	200	200	55	8,5	
			90 L																	1,5
			100																	2,2
20CK	28LRS28	100	3	292	161	28	Nr.4 M12	Nr.4 ø13	28	32	215	215	180	180	Nr.8 M12	250	250	65	24	
			112 M																	4
			132 L																	9,2
30CK	38LRS38	132 L	9,2	350	210	38	Nr.4 M12	Nr.4 ø13	38	45	265	265	230	230	Nr.8 M12	300	300	82	36,5	
30PCK	42LRS42	160 M	11	400	210	42	Nr.4 M16	Nr.4 ø17	42	45	300	300	250	250	Nr.8 M16	350	350	112	40	
			160 L																	15
40PCK	48LRS48	180 M	18,5	400	255	48	Nr.4 M16	Nr.4 Ø17	48	55	300	300	350	250	Nr.8 M16	350	350	112	42	
			180 L																	22

\* Weight with oil

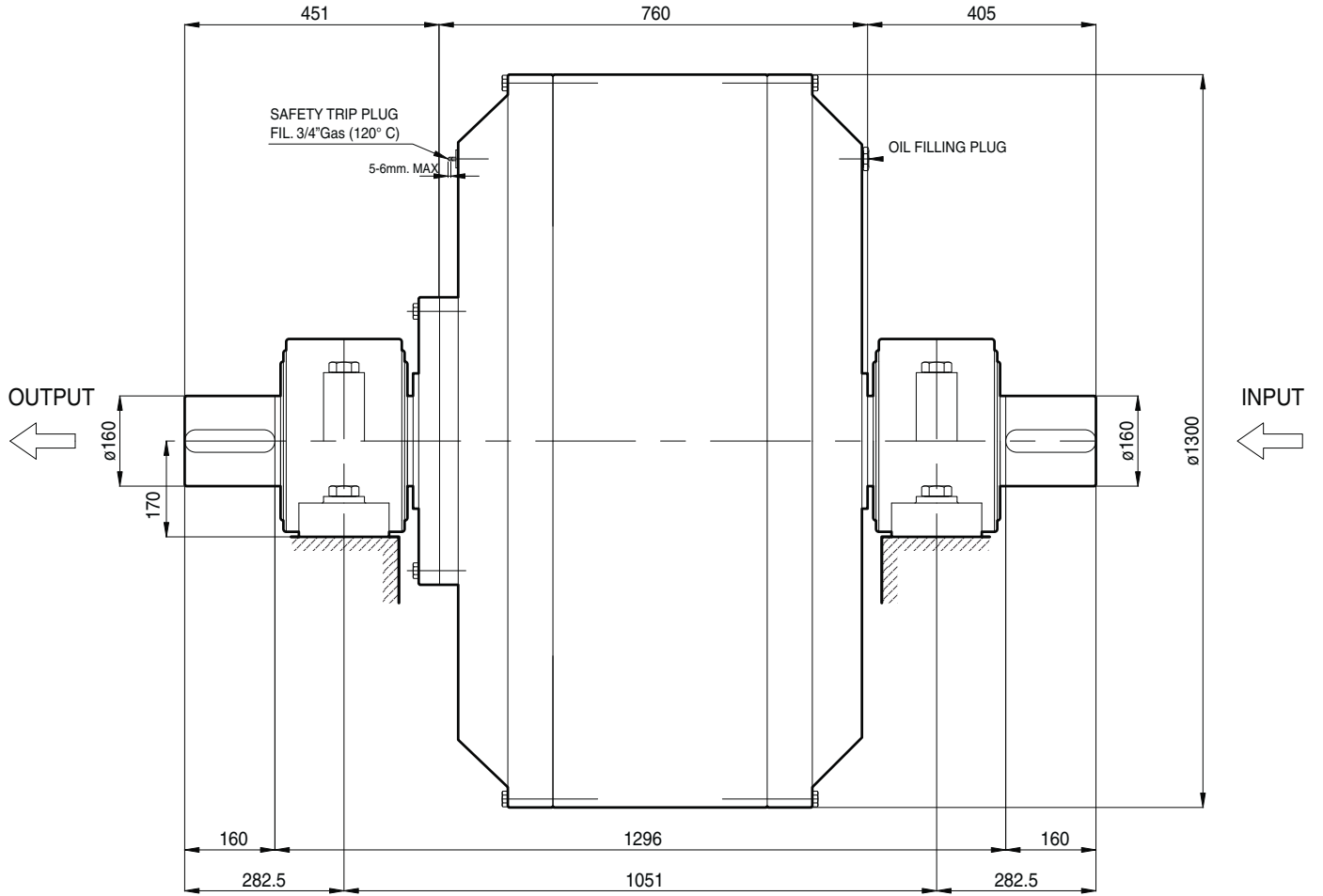

Specify installation required "STANDARD ASSEMBLY" or "REVERSE ASSEMBLY"  
see page 12

WEIGHT Kg. Without oil	OIL CAPACITY max. lt.	OIL DENSITY	WEIGHT Kg. max. with oil
2400	400	0,88	2752



**THE DELAY FILL CHAMBERS "SCF AND DCF" CAN BE ALSO FITTED TO THE VERSIONS "J"- "H"- "Z"**

**ROTOFLUID BETA X** for pulley with bearing support under the belts tension.

BUILT-IN PULLEY  
TYPE X-XC-XM-XN

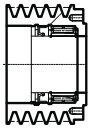

DEMOUNTABLE PULLEY  
TYPE XJ-NJ

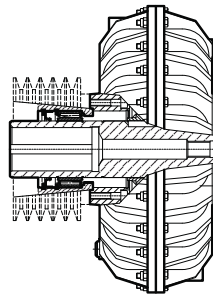
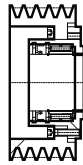

page 36/37

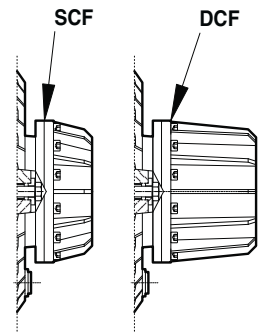

**ROTOFLUID BETA J** with bearing supported output sleeve for externally bolted v-belt pulley J-JA-JG

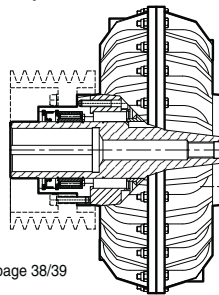

page 38/39

**ROTOFLUID BETA H** with bearing supported output sleeve keyed v-belt pulley "P"

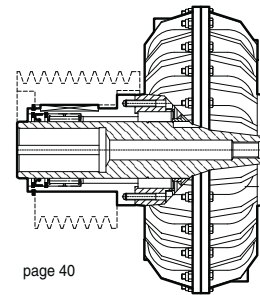

page 40

**ROTOFLUID BETA Z**

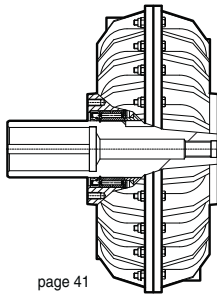

page 41

**ROTOFLUID BETA Z** for externally bolted demountable pulley F-T-FT-TG-TM-TR

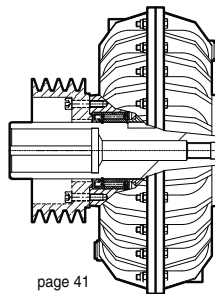

page 41

**ROTOFLUID BETA ZI** for externally bolted built-in pulley I-IF-IG

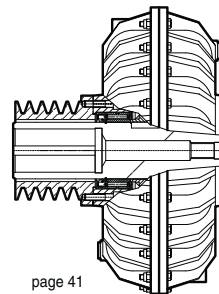

page 41

**SPECIAL VERSIONS**

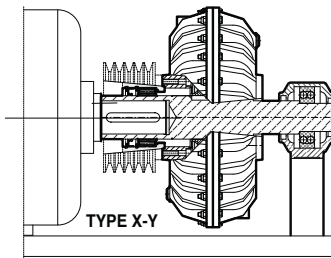

TYPE X-Y

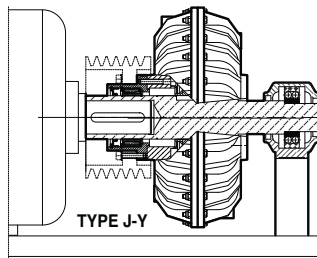

TYPE J-Y

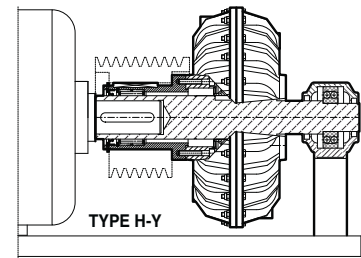

TYPE H-Y

**ROTOFLUID ALFA**  
in-line version for pulley

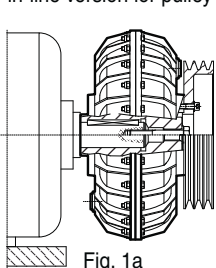

Fig. 1a

Fig. 1b

**ROTOFLUID ALFA**  
in-line for pulley with support

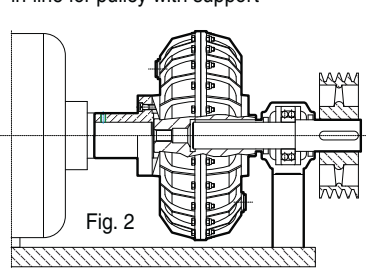

Fig. 2

**ROTOFLUID ALFA**  
in-line version for pulley with double support

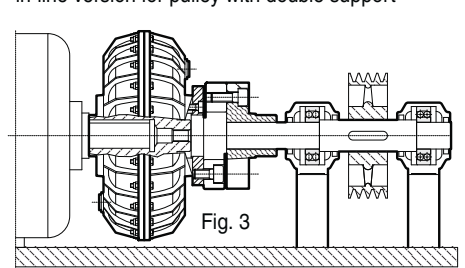

Fig. 3

Fig. 1-2 HORIZONTAL SHAFT

Fig. 3-4 VERTICAL SHAFT

In case of order specify mounting figure (if different from STANDARD)

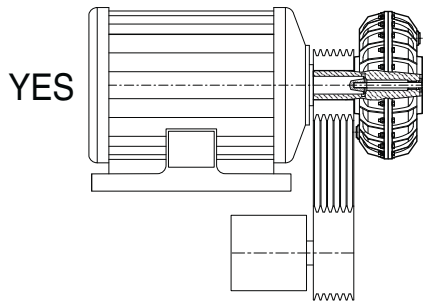

Fig. 1  
STANDARD

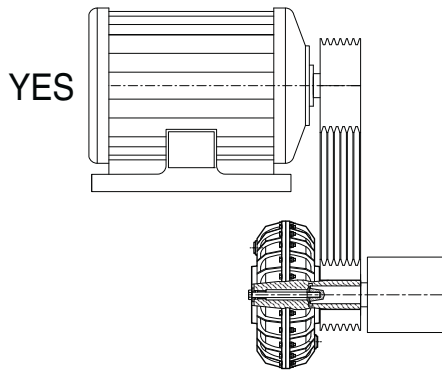
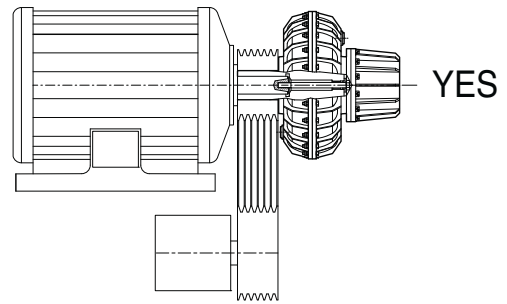

Fig. 2

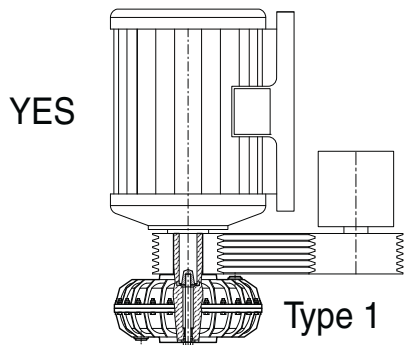
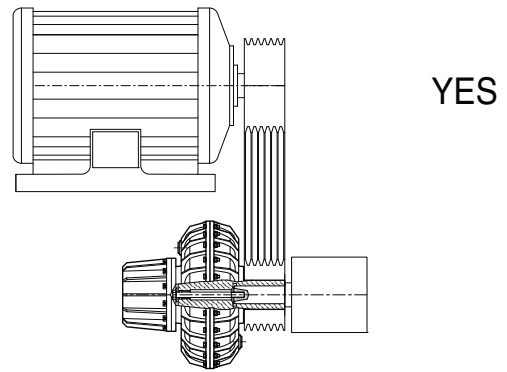

Fig. 3

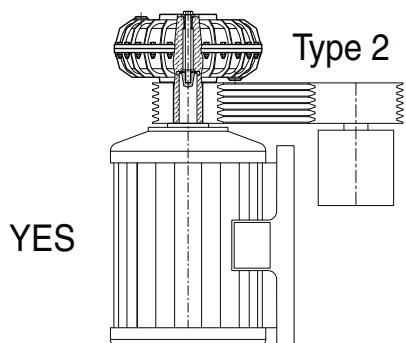
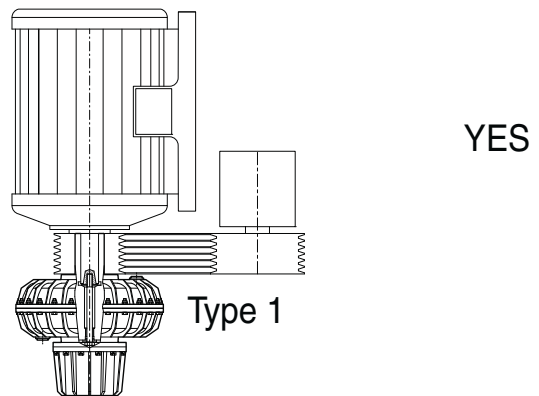
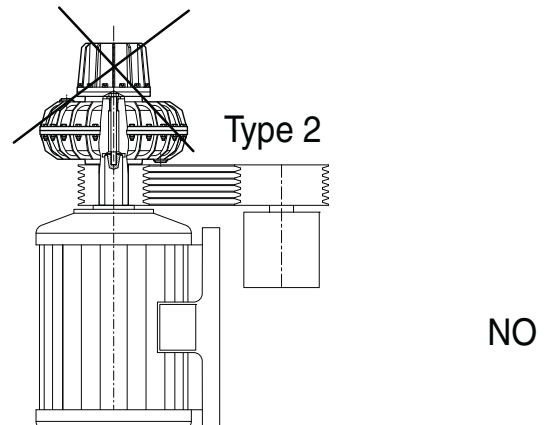
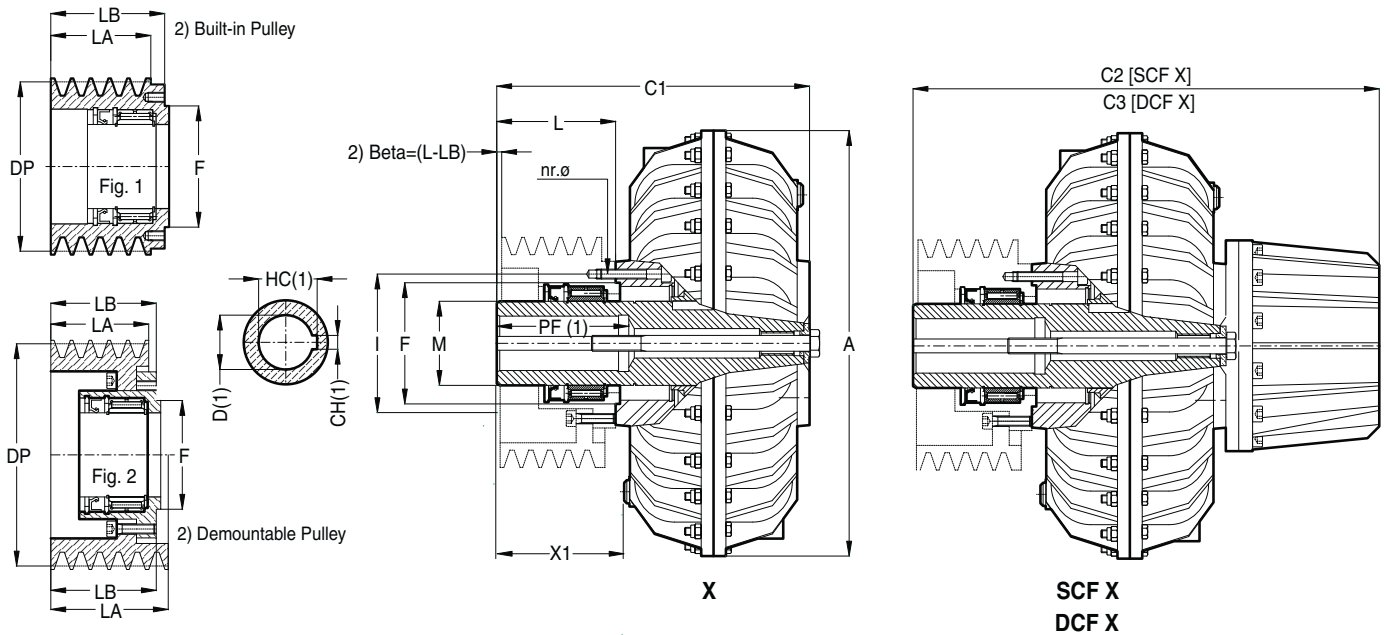

Fig. 4





NOTE: 1) FOR BORE AND KEYWAY DIMENSIONS SEE SHEET. 10-019D

2) FOR THE CHOICE OF THE ASSEMBLING COUPLING-PULLEY, SEE "WESTCAR PULLEYS" CATALOGUE

Size	X										SCF X			DCF X			
	Dimensions mm.										Weight Kg.*	Dimensions mm.		Weight Kg.*	Dimensions mm.		Weight Kg.*
	Type	D	A	C1	F	I	L	M	nr-ø	X1		Type	C2		Type	C3	
20	X 103	38-42	230	218	62	78	103	55	6-M6	120	7	-	-	-	-	-	-
30	X 68	28-38-42	290	218	75	100	68	60	8-M8	77	14	SCF X 68	273	16,4	DCF X 68	313	17
	X 80	48-55		230			80	70		89	14,5	SCF X 80	285	16,9	DCF X 80	325	17,5
	X 88	28-38-42		238			88	60		97	14,8	SCF X 88	293	17,2	DCF X 88	333	17,8
	X 112	28-38-42		262			112	60		121	15,5	SCF X 112	317	17,9	DCF X 112	357	18,5
	X 114	48		264			114	65		123	15,5	SCF X 114	319	17,9	DCF X 114	359	18,5
	X 135	42-48-55		285			135	70		144	16	SCF X 135	340	18,4	DCF X 135	380	19
30P	X 68	28-38-42	327	218	75	100	68	60	8-M8	72	22	SCF X 68	273	24,4	DCF X 68	313	25
	X 80	48-55		230			80	70		84	22,5	SCF X 80	285	24,9	DCF X 80	325	25,5
	X 88	28-38-42		238			88	60		92	22,8	SCF X 88	293	25,2	DCF X 88	333	25,8
	X 112	28-38-42		262			112	60		116	23,5	SCF X 112	317	25,9	DCF X 112	357	26,5
	X 114	48		264			114	65		118	23,5	SCF X 114	319	25,9	DCF X 114	359	26,5
	X 135	42-48-55		285			135	70		139	24	SCF X 135	340	26,4	DCF X 135	380	27
40P	X 64	42-48	338	247	125	80	64	8-M8	88	23	SCF X 64	305	26,7	DCF X 64	377	28,2	
	X 90	38-42-48-55-60		273			90		114	25	SCF X 90	331	28,7	DCF X 90	403	30,2	
	X 118	38-42-48-55-60		301			118		142	27	SCF X 118	359	30,7	DCF X 118	431	32,2	
	X 142	38-42-48-55-60		325			142		166	30	SCF X 142	383	33,7	DCF X 142	455	35,2	
	X N64	42-48		247			145		97	88	28	SCF X N64	305	31,7	DCF X N64	377	33,2
	X N90	38-42-48-55-60		273			145		123	114	30	SCF X N90	331	33,7	DCF X N90	403	35,2
	X N118	38-42-48-55-60		301			145		151	142	32	SCF X N118	359	35,7	DCF X N118	431	37,2
	X N142	38-42-48-55-60		325			145		175	166	35	SCF X N142	383	38,7	DCF X N142	455	40,2
50	X 90	42-48-55-60-65	430	244	110	140	90	8-M10	96	32,5	SCF X 90	324	38,3	DCF X 90	399	40,5	
	X 120			274			120		126	33,5	SCF X 120	354	39,3	DCF X 120	429	41,5	
	X 155			309			155		161	34,5	SCF X 155	389	40,3	DCF X 155	464	42,5	
	X 180			334			180		186	35,5	SCF X 180	414	41,3	DCF X 180	489	43,5	
55	X 90	42-48-55-60-65	430	286	110	140	90	8-M10	96	41	SCF X 90	366	46,8	DCF X 90	441	49	
	X 120	42-48-55-60-65		316			120		85	126	42	SCF X 120	396	47,8	DCF X 120	471	50
	X 155	42-48-55-60-65		351			155		85	161	43	SCF X 155	431	48,8	DCF X 155	506	51
	X 160	75		356			160		105	166	43	SCF X 160	436	48,8	DCF X 160	511	51
	X 200	42-48-55-60-65		396			200		85	206	44	SCF X 200	476	49,8	DCF X 200	551	52
	X 230	75		426			230		105	236	46	SCF X 230	506	51,8	DCF X 230	581	54

\* Weight with oil - Standard bores in heavy type

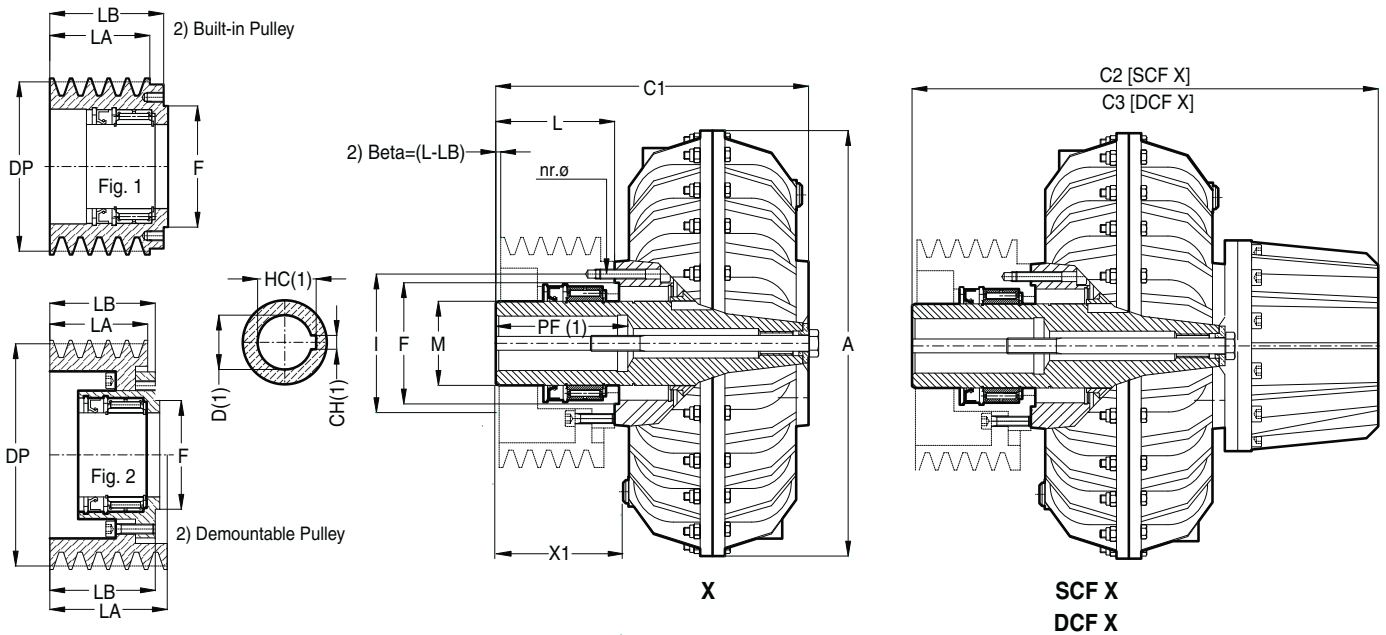

NOTE: 1) FOR BORE AND KEYWAY DIMENSIONS SEE SHEET. 10-019D

2) FOR THE CHOICE OF THE ASSEMBLING COUPLING-PULLEY, SEE "WESTCAR PULLEYS" CATALOGUE

Size	X										SCF X			DCF X			
	Dimensions mm.										Weight	Dimensions mm.		Weight	Dimensions mm.		Weight
	Type	D	A	C1	F	I	L	M	nr-Ø	X1	Kg.*	Type	C2	Kg.*	Type	C3	Kg.*
60	X 130	55-60-65-75-80	520	302	125	160	130	110	8-M10	136	50	SCF X 130	392	58,4	DCF X 130	472	62
	X 170			342			170			176	53	SCF X 170	432	61,4	DCF X 170	512	65
	X 178			350			178			184	53	SCF X 178	440	61,4	DCF X 178	520	65
	X 218			390			218			224	55	SCF X 218	480	63,4	DCF X 218	560	67
	X 230			402			230			236	56	SCF X 230	492	64,4	DCF X 230	572	68
65	X 130	60-65-75-80	520	350	125	160	130	110	8-M10	136	69	SCF X 130	440	77,4	DCF X 130	520	81
	X 170			390			170			176	72	SCF X 170	480	80,4	DCF X 170	560	83
	X 220			440			220			226	76	SCF X 220	530	84,4	DCF X 220	610	88
	X 255			475			255			261	79	SCF X 255	565	87,4	DCF X 255	645	91
70P	X 170	75-80-90-100	640	380	150	195	170	120	8-M12	170	111	SCF X 170	490	118	DCF X 170	605	125
	X 210			420			210			210	114	SCF X 210	530	121	DCF X 210	645	128
	X 230			440			230			230	117	SCF X 230	550	124	DCF X 230	665	131
	X 275			485			275			275	121	SCF X 275	595	128	DCF X 275	710	135
75P	X 160	80-90-100	640	420	150	195	160	120	8-M12	160	142	SCF X 160	530	143	DCF X 160	645	150
	X 210			470			210			210	147	SCF X 210	580	148	DCF X 210	695	155
	X 230			490			230			230	153	SCF X 230	600	154	DCF X 230	715	161
	X 275			535			275			275	158	SCF X 275	645	159	DCF X 275	760	166
80P	X 160A	Ø max. 100	810	386	190	230	160	140	8-M14	160	192	SCF X 160A	504	201	DCF X 160A	604	213
	X 210A	Ø max. 100		436			210	140	8-M14	210	202	SCF X 210A	554	211	DCF X 210A	654	223
	X 255A	Ø max. 100		481			255	140	8-M14	255	207	SCF X 255A	599	216	DCF X 255A	699	228
	X 255B	Ø max. 125		481			255	160	8-M16	255	215	SCF X 255B	599	224	DCF X 255B	699	236
85P	X 160A	Ø max. 100	810	460	190	230	160	140	8-M14	160	270	SCF X 160A	578	279	DCF X 160A	678	291
	X 230A	Ø max. 100		530			230	140	8-M14	230	280	SCF X 230A	648	289	DCF X 230A	748	301
	X 255A	Ø max. 100		555			255	140	8-M14	255	290	SCF X 255A	673	299	DCF X 255A	773	311
	X 255B	Ø max. 125		555			255	160	8-M16	255	298	SCF X 255B	673	307	DCF X 255B	773	319

\*Weight with oil - • PER D=100 - M=135 - Standard bores in heavy type

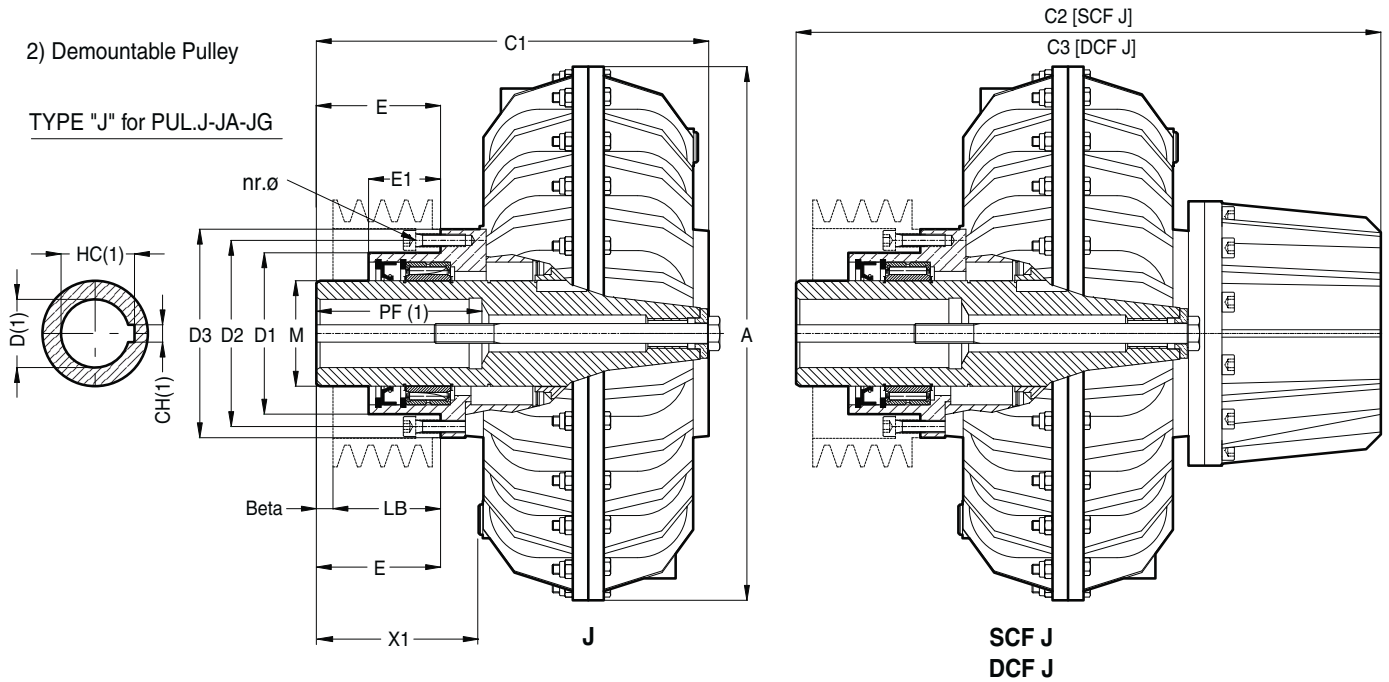

NOTE : 1) FOR BORE AND KEYWAY DIMENSIONS SEE SHEET. 10-019D

2) FOR THE CHOICE OF THE ASSEMBLING COUPLING-PULLEY, SEE "WESTCAR PULLEYS" CATALOGUE

Size	J												SCF J			DCF J				
	Dimensions mm.											Weight	Dimensions mm.		Weight	Dimensions mm.		Weight		
	Type	D	A	C1	D1 h7	D2	D3	E	E1	M	nr.-Ø	X1	Kg *	Type	C2	Kg *	Type	C3	Kg *	
20	J 70	19-24-28	229	185	60	75	92	70	12	45	6-M8	77	6,5	-	-	-	-	-	-	
	J 103	28-38		218	75	90	104	85	32	55		120	9	-	-	-	-	-	-	-
30	J 68	28-38-42	290	218	85	100	114	50		60	8-M8	77	15	SCF J 68	273	17,4	DCF J 68	313	18	
	J 80	48-55		230	96	110	124	62		70		89	16	SCF J 80	285	18,4	DCF J 80	325	19	
	J 88	28-38-42		238	85	100	114	70	45	60		97	16	SCF J 88	293	18,4	DCF J 88	333	19	
	J 112	28-38-42		262	85	100	114	94		60		121	19	SCF J 112	317	21,4	DCF J 112	357	22	
	J 135	42-48-55		285	96	110	124	117		70		144	20	SCF J 135	340	22,4	DCF J 135	380	23	
30P	J 68	28-38-42	327	218	85	100	114	50		60	8-M8	72	23	SCF J 68	273	25,4	DCF J 68	313	26	
	J 80	48-55		230	96	110	124	62		70		84	24	SCF J 80	285	26,4	DCF J 80	325	27	
	J 88	28-38-42		238	85	100	114	70	45	60		92	24	SCF J 88	293	26,4	DCF J 88	333	27	
	J 112	28-38-42		262	85	100	114	94		60		116	27	SCF J 112	317	29,4	DCF J 112	357	30	
	J 135	42-48-55		285	96	110	124	117		70		139	28	SCF J 135	340	30,4	DCF J 135	380	31	
40P	J 64	42-48	338	247				63			8-M8	88	24	SCF J 64	305	28	DCF J 64	377	29	
	J 90	38-42-48-55-60		273	112	130	145	89		60		80	114	26	SCF J 90	331	30	DCF J 90	403	31
	J 118	38-42-48-55-60		301				117				142	29	SCF J 118	359	33	DCF J 118	431	34	
	J 142	38-42-48-55-60		325				141				166	31	SCF J 142	383	35	DCF J 142	455	36	
50	J 90		430	244				70			8-M10	96	40	SCF J 90	324	46	DCF J 90	399	48	
	J 120	42-48-55-60-65		274	130	150	170	100		58		85	126	41	SCF J 120	354	47	DCF J 120	429	49
	J 155			309				135				161	42	SCF J 155	389	48	DCF J 155	464	50	
	J 180			334				160				186	45	SCF J 180	414	51	DCF J 180	489	53	
55	J 90		430	286				70			8-M10	96	48	SCF J 90	366	54	DCF J 90	441	56	
	J 120	42-48-55-60-65		316	130	150	170	100		58		85	126	50	SCF J 120	396	56	DCF J 120	471	58
	J 155			351				135				161	52	SCF J 155	431	58	DCF J 155	506	60	
	J 200			396				180				206	55	SCF J 200	476	61	DCF J 200	551	63	

\* Weight with oil – Standard bores in heavy type

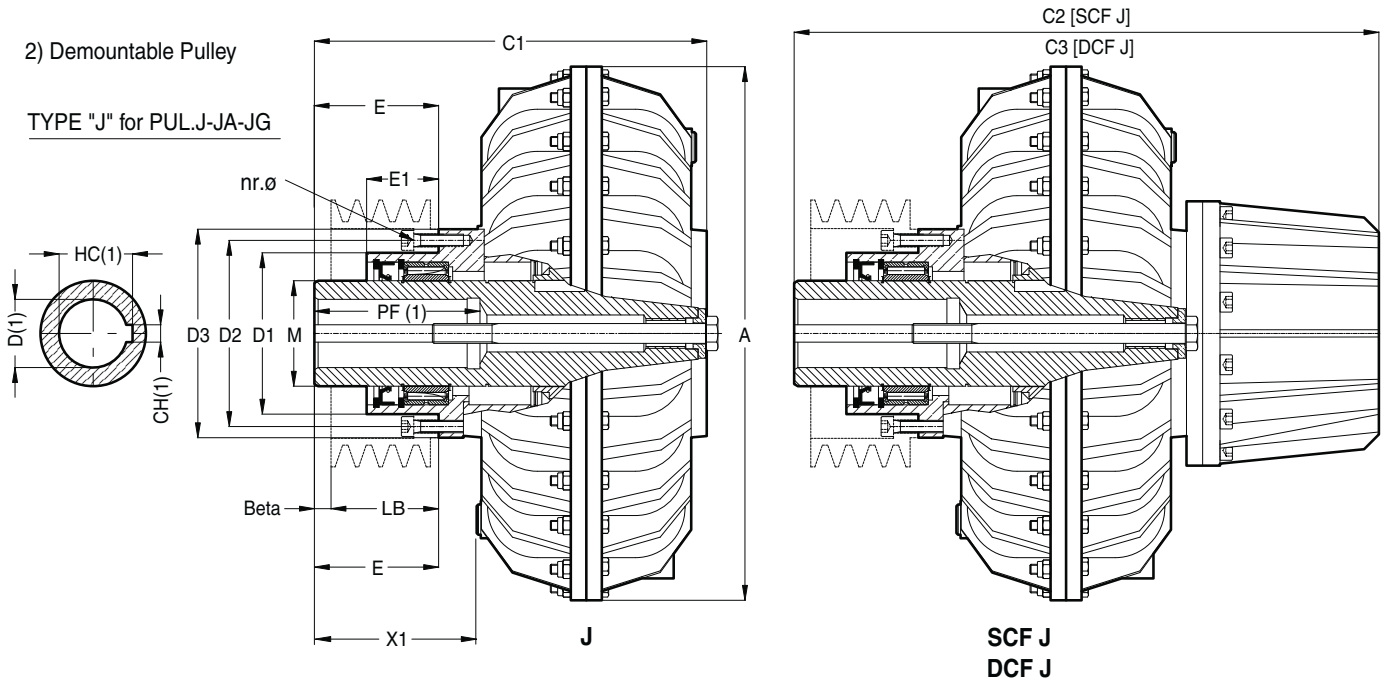

NOTE: 1) FOR BORE AND KEYWAY DIMENSIONS SEE SHEET. 10-019D  
2) FOR THE CHOICE OF THE ASSEMBLING COUPLING-PULLEY, SEE "WESTCAR PULLEYS" CATALOGUE

Size	J												SCF J			DCF J			
	Dimensions mm.												Weight	Dimensions mm.		Weight	Dimensions mm.		Weight
	Type	D	A	C1	D1 h7	D2	D3	E	E1	M	nr.-Ø	X1	Kg *	Type	C2	Kg *	Type	C3	Kg *
60	J 130	55-60-65-75-80	520	302	150	170	186	110	88	110	8-M10	136	65	SCF J 130	392	74	DCF J 130	472	77
	J 170			342				150				176	70	SCF J 170	432	79	DCF J 170	512	82
	J 178			350				170				184	71	SCF J 178	440	80	DCF J 178	520	83
	J 218			390				198				224	76	SCF J 218	480	85	DCF J 218	560	88
	J 230			402				210				236	80	SCF J 230	492	89	DCF J 230	572	92
65	J 130	55-60-65-75-80	520	350	150	170	186	110	88	110	8-M10	136	83	SCF J 130	440	92	DCF J 130	520	95
	J 170			390				150				176	88	SCF J 170	480	97	DCF J 170	560	100
	J 220			440				200				226	94	SCF J 220	530	103	DCF J 220	610	106
	J 255			475				235				261	100	SCF J 255	565	109	DCF J 255	645	112
70P	J 170	75-80-90-100	640	380	188	210	230	140	100	•120	8-M12	170	115	SCF J 170	490	128	DCF J 170	605	135
	J 210			420				180				210	118	SCF J 210	530	131	DCF J 210	645	138
	J 230			440				200				230	121	SCF J 230	550	134	DCF J 230	665	141
	J 275			485				245				275	125	SCF J 275	595	138	DCF J 275	710	145
75P	J 160	80-90-100	640	420	188	210	230	130	100	•120	8-M12	160	150	SCF J 160	530	163	DCF J 160	645	170
	J 210			470				180				210	153	SCF J 210	580	166	DCF J 210	695	173
	J 230			490				200				230	154	SCF J 230	600	167	DCF J 230	715	174
	J 275			535				245				275	160	SCF J 275	645	173	DCF J 275	760	180
80P	J 160A	Ø max. 100	810	386	214	240	270	130	130	140	8-M14	160	185	SCF J 160A	504	201	DCF J 160A	604	213
	J 210A	Ø max. 100		436	214	240	270	180	130	140	8-M14	210	195	SCF J 210A	554	211	DCF J 210A	654	223
	J 255A	Ø max. 100		481	214	240	270	225	130	140	8-M14	255	200	SCF J 255A	599	216	DCF J 255A	699	228
	J 255B	Ø max. 125		481	225	250	276	143	43	160	8-M16	255	208	SCF J 255B	599	224	DCF J 255B	699	236
85P	J 160A	Ø max. 100	810	460	214	240	270	130	130	140	8-M14	160	250	SCF J 160A	578	266	DCF J 160A	678	178
	J 230A	Ø max. 100		530	214	240	270	200	130	140	8-M14	230	260	SCF J 230A	648	276	DCF J 230A	748	288
	J 255A	Ø max. 100		555	214	240	270	225	130	140	8-M14	255	270	SCF J 255A	673	286	DCF J 255A	773	298
	J 255B	Ø max. 125		555	225	250	276	143	43	160	8-M16	255	278	SCF J 255B	673	294	DCF J 255B	773	306

\*Weight with oil - • PER D=100 - M=135 - Standard bores in heavy type



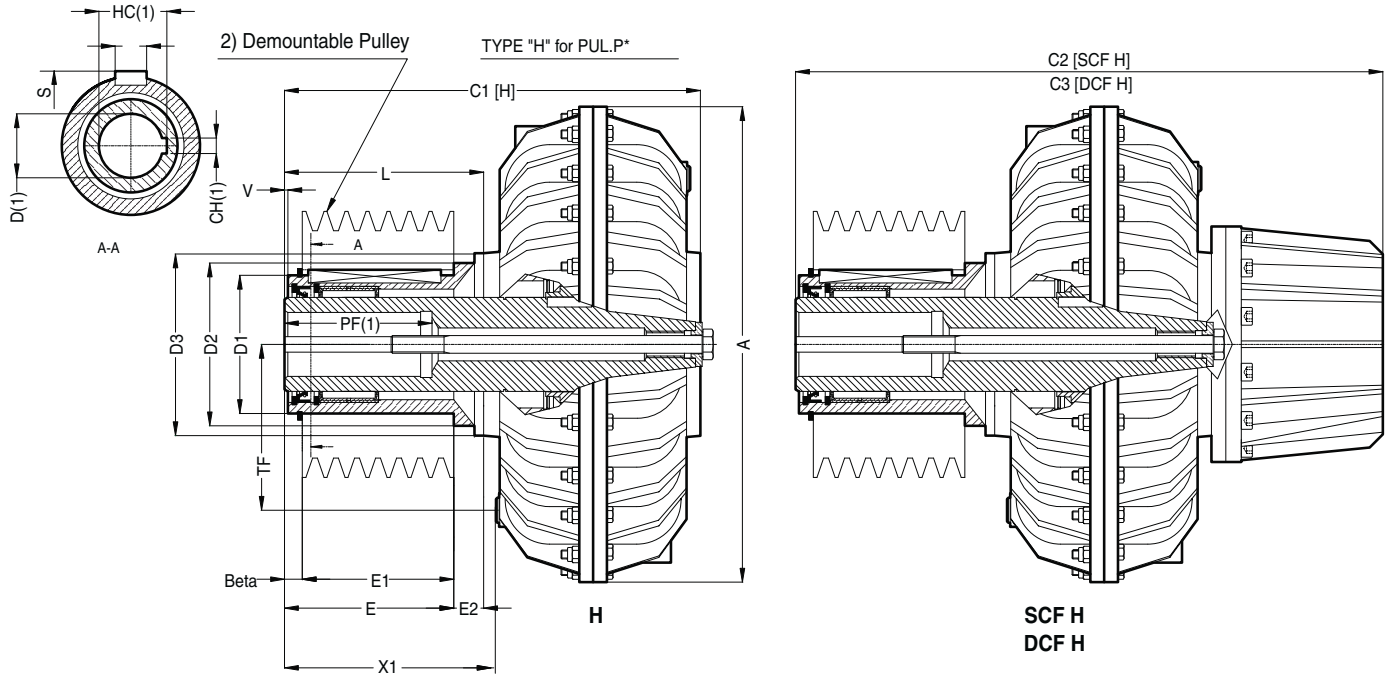

NOTE: ( 1) FOR BORE AND KEYWAY DIMENSIONS SEE SHEET. 10-019D

Size	H															SCF H			DCF H				
	Dimensions mm															Weight	Dimensions mm		Weight	Dimensions mm		Weight	
	Type	D	A	C1	D1 h7	D2	D3	E	E1	E2	(L)	R	S	V	X1	Kg	Type	C2	Kg	Type	C3	Kg.*	
20	H 85	28-38-42	229	218	85	90	90	86	70	30	(103)	12	88,3	6	120	9,3	-	-	-	-	-		
30	H 85	28-38-42	290	262	85	90	86	72	40	(112)	12	88,3	4	121	16,7	SCF H 85	317	19	DCF H 85	357	19,7		
	H 95	48		264	95	105		117	86	72	38	(114)	12	98,3	8	123	18	SCF H 95	319	20,4	DCF H 95	359	21
	H 110	42-48-55		285	110	117		116,5	105	30	(135)	16	114,3	4	144	20	SCF H 110	340	22,4	DCF H 110	380	23	
30P	H 85	28-38-42	327	262	85	90	86	72	40	(112)	12	88,3	4	116	24,7	SCF H 85	317	27	SCF H 85	357	27,7		
	H 95	48		264	95	105		117	86	72	38	(114)	12	98,3	8	118	26	SCF H 95	319	28,4	DCF H 95	359	29
	H 110	42-48-55		285	110	117		116,5	105	30	(135)	16	114,3	4	139	28	SCF H 110	340	30,4	DCF H 110	380	31	
40P	H 110	38-42-48-55-60	338	301	110	145	145	124	112	21	(118)	16	114,3	4	142	27,6	SCF H 110	359	31,5	DCF H 110	431	32,8	
	H 125	38-42-48-55-60		325	125	138	145	134	120	32	(142)	18	129,4	6	166	31,3	SCF H125	383	35	DCF H125	455	36,5	
50	H 125	42-48-55-60-65	430	334	125	165	170	153	140	39	(180)	18	129,4	3	186	41,8	SCF H 125	414	47,5	DCF H 125	489	49,8	
55	H 125	42-48-55-60-65	430	396	125	165	170	173	140	39	(200)	18	129,4	23	206	52	SCF H 125	476	57,8	DCF H 125	551	60	
	H 150	75		426	150	165	170	173	140	87	(230)	16	154,3		236	60	SCF H150	506	65,8	DCF H150	581	68	
60	H 150	48-55-60-65-75-80	520	402	150	179	188	203	190	33	(230)	16	154,3	3	236	70	SCF H 150	492	78,4	DCF H 150	572	82	
65	H 150	55-60-65-75-80	520	475	150	179	188	228	190	33	(255)	16	154,3	28	261	93	SCF H 150	565	101,4	DCF H 150	645	105	
70P	H 200	75-80-90-100	640	485	200	215	227	245	190	34	(275)	20	204,8	45	275	131	SCF H 200	595	144	DCF H 200	710	151	
75P	H 200	80-90-100	640	535	200	215	227	245	190	34	(275)	20	204,8	45	275	174	SCF H 200	645	187	DCF H 200	760	194	

\* Weight with oil - Standard bores in heavy type

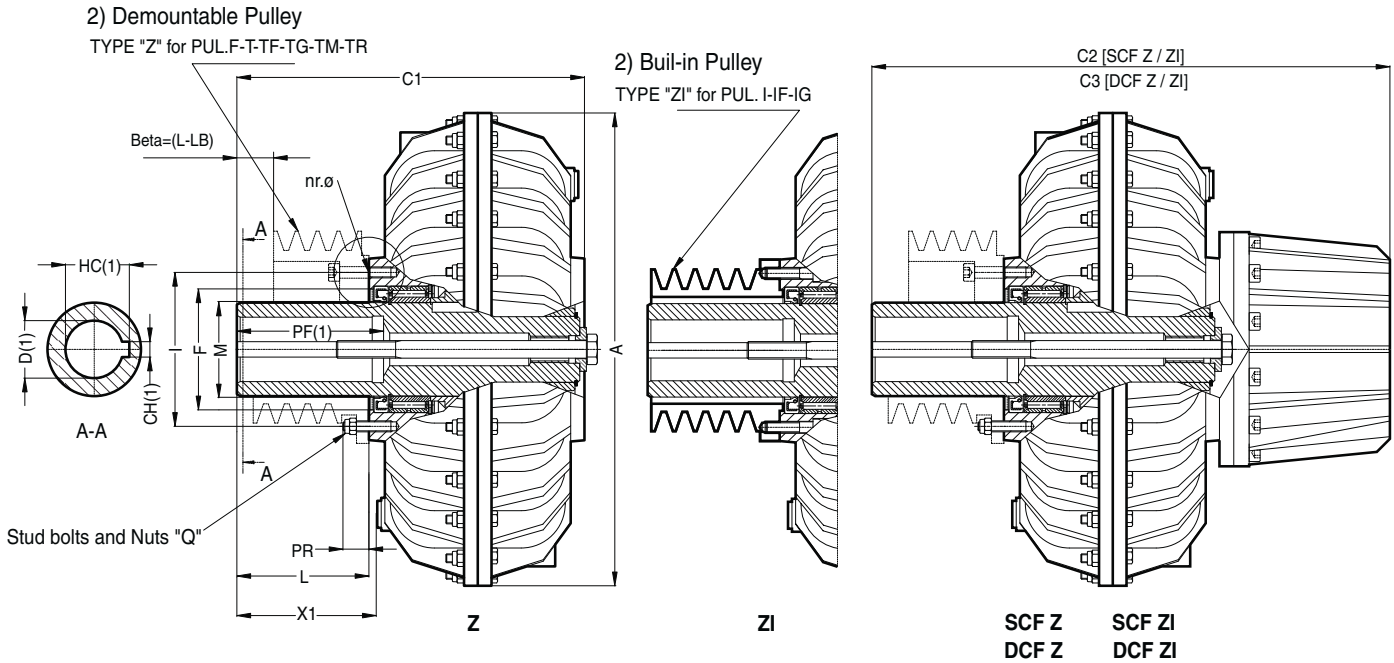

NOTE: 1) FOR BORE AND KEYWAY DIMENSIONS SEE SHEET. 10-019D

2) FOR THE CHOICE OF THE ASSEMBLING COUPLING-PULLEY, SEE "WESTCAR PULLEYS" CATALOGUE

Size	Z / ZI											SCF Z / ZI				DCF Z / ZI					
	Dimensions mm.											Weight Kg. *	Dimensions mm.			Weight Kg. *	Dimensions mm.			Weight Kg. *	
	Type	D	A	C1	F H7	I	L	M	PR	nr. ∅	X1		Type	C2	Type		C3				
10	Z 45	-	14-19-24	133	47	60	45	35	14	6-M6	47	4,2	-	-	-	-	-	-	-		
	Z 55	ZI 55	14-19-24	192	143	47	60	55	35	14	6-M6		57	-	-	-	-	-	-	-	
	Z 56	ZI 56	28	144	52	68	56	40			58										
20	Z 55	-	19-24-28	170			55	45			62	6,2	-	-	-	-	-	-	-		
	Z 70	ZI 70	19-24-28	230	185	62	78	70	45	18	6-M8		77	-	-	-	-	-	-	-	
	Z 69	ZI 69	38	184			69	53			76										
30	Z 68	-	28-38-42	218			68				77	13,5	SCF Z 68	SCF ZI 68	273	15,9	DCF Z 68	DCF ZI 68	313	16,5	
	Z 88	-		290	238	75	100	88	60	18	8-M8	97	13,8	SCF Z 88	SCF ZI 88	293	16,2	DCF Z 88	DCF ZI 88	325	16,8
	Z 112	ZI 112		262			112					121	14	SCF Z 112	SCF ZI 112	317	16,4	DCF Z 112	DCF ZI 112	357	17
30P	Z 68	ZI 68	28-38-42	218			68				72	21,5	SCF Z 68	SCF ZI 68	273	23,9	DCF Z 68	DCF ZI 68	313	24,5	
	Z 88	ZI 88		327	238	75	100	88	60	18	8-M8	92	21,8	SCF Z 88	SCF ZI 88	293	24,2	DCF Z 88	DCF ZI 88	325	24,8
	Z 112	ZI 112		262			112					116	22	SCF Z 112	SCF ZI 112	317	24,4	DCF Z 112	DCF ZI 112	357	25
40P	Z 64	-	38-42-48-55-60	247			64				88	22,5	SCF Z 64	SCF ZI 64	305	26,2	DCF Z 64	DCF ZI 64	377	27,7	
	Z 90	-		338	273	100	125	90	80	25	8-M10	114	23	SCF Z 90	SCF ZI 90	331	25,7	DCF Z 90	DCF ZI 90	403	28,2
	Z 118	ZI 118		301			118					142	23,5	SCF Z 118	SCF ZI 118	359	27,2	DCF Z 118	DCF ZI 118	431	28,7
50	Z N90	-	42-48-55-60-65	430	244	110	140	90	85	25	96	32,5	SCF Z N90	SCF ZI N90	324	38,3	DCF Z N90	DCF ZI N90	399	40,5	
	Z N120	ZI N120		274			120				126	33,5	SCF Z N120	SCF ZI N120	354	39,3	DCF Z N120	DCF ZI N120	429	41,5	
55	Z N90	-	42-48-55-60-65	430	286		90				96	41	SCF Z N90	SCF ZI N90	366	46,8	DCF Z N90	DCF ZI N90	441	49	
	Z N120	-		430	316	110	140	120	85	25	8-M10	126	42	SCF Z N120	SCF ZI N120	396	47,8	DCF Z N120	DCF ZI N120	471	50
	Z N155	ZI N155		351			155					161	43	SCF Z N155	SCF ZI N155	431	48,8	DCF Z N155	DCF ZI N155	506	51
60	Z N130	-	48-55-60-65-75-80	520	302	125	160	130	110	25	8-M10	136	50	SCF Z N130	-	392	58,4	DCF Z N130	-	472	62
65	Z N170	-	55-60-65-75-80	520	390	125	160	170	110	25	8-M10	176	72	SCF Z N170	-	480	80,4	DCF Z N170	-	560	84

\* Weight with oil - Standard bores in heavy type

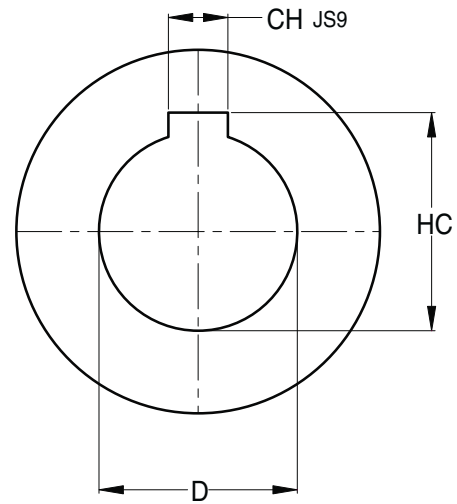
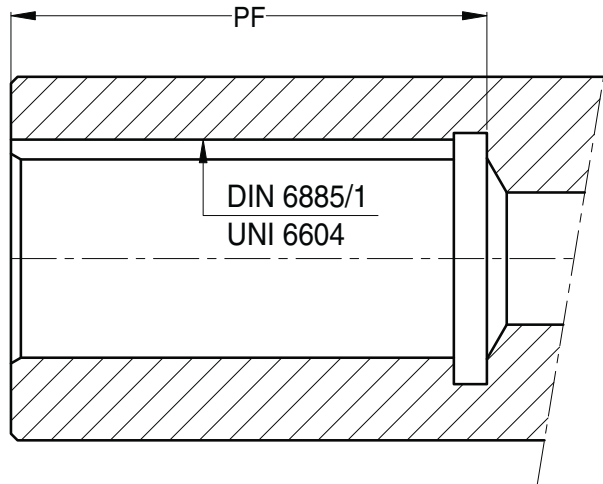

D	Toll.	PF	CH	HC	Toll.
10	H7	25	3	11,4	+0,1 0
<b>11 *</b>		<b>25</b>	<b>4</b>	<b>12,8</b>	
12		25	4	13,8	
13		32	5	15,3	
<b>14 *</b>		<b>32</b>	<b>5</b>	<b>16,3</b>	
15		32	5	17,3	
16		32	5	18,3	
17		42	5	19,3	
18		42	6	20,8	
<b>19 *</b>		<b>45</b>	<b>6</b>	<b>21,8</b>	
20		45	6	22,8	
21		45	6	23,8	
22		55	6	24,8	
23		55	8	26,3	
<b>24 *</b>		<b>55</b>	<b>8</b>	<b>27,3</b>	
25		55	8	28,3	
26		65	8	29,3	
27		65	8	30,3	
<b>28 *</b>		<b>65</b>	<b>8</b>	<b>31,3</b>	
30	G7	65	8	33,3	+0,2 0
32		65	10	35,3	
33		82	10	36,3	
34		82	10	37,3	
35		82	10	38,3	
<b>38 *</b>		<b>82</b>	<b>10</b>	<b>41,3</b>	

D	Toll.	PF	CH	HC	Toll.
40	G7	112	12	43,3	+0,2 0
<b>42 *</b>		<b>112</b>	<b>12</b>	<b>45,3</b>	
45		112	14	48,8	
<b>48 *</b>		<b>112</b>	<b>14</b>	<b>51,8</b>	
50		112	14	53,8	
<b>55 *</b>		<b>112</b>	<b>16</b>	<b>59,3</b>	
<b>60 *</b>		<b>142</b>	<b>18</b>	<b>64,4</b>	
<b>65 *</b>		<b>142</b>	<b>18</b>	<b>69,4</b>	
<b>70 *</b>		<b>142</b>	<b>20</b>	<b>74,9</b>	
<b>75 *</b>		<b>142</b>	<b>20</b>	<b>79,9</b>	
<b>80 *</b>		<b>172</b>	<b>22</b>	<b>85,4</b>	
<b>85 *</b>		<b>172</b>	<b>22</b>	<b>90,4</b>	
<b>90 *</b>		<b>172</b>	<b>25</b>	<b>95,4</b>	
95		172	25	100,4	
<b>100 *</b>		<b>212</b>	<b>28</b>	<b>106,4</b>	
105		212	28	111,4	
<b>110 *</b>		<b>212</b>	<b>28</b>	<b>116,4</b>	
115		212	32	122,4	
120		252	32	127,4	
<b>125 *</b>		<b>252</b>	<b>32</b>	<b>132,4</b>	
130	252	32	137,4		
<b>135 *</b>	<b>252</b>	<b>36</b>	<b>143,4</b>		
140	252	36	148,4		
160	252	40	169,4		
180	252	45	190,4		

\* STANDARD BORES FOR UNEL MEC ELECTRIC MOTORS

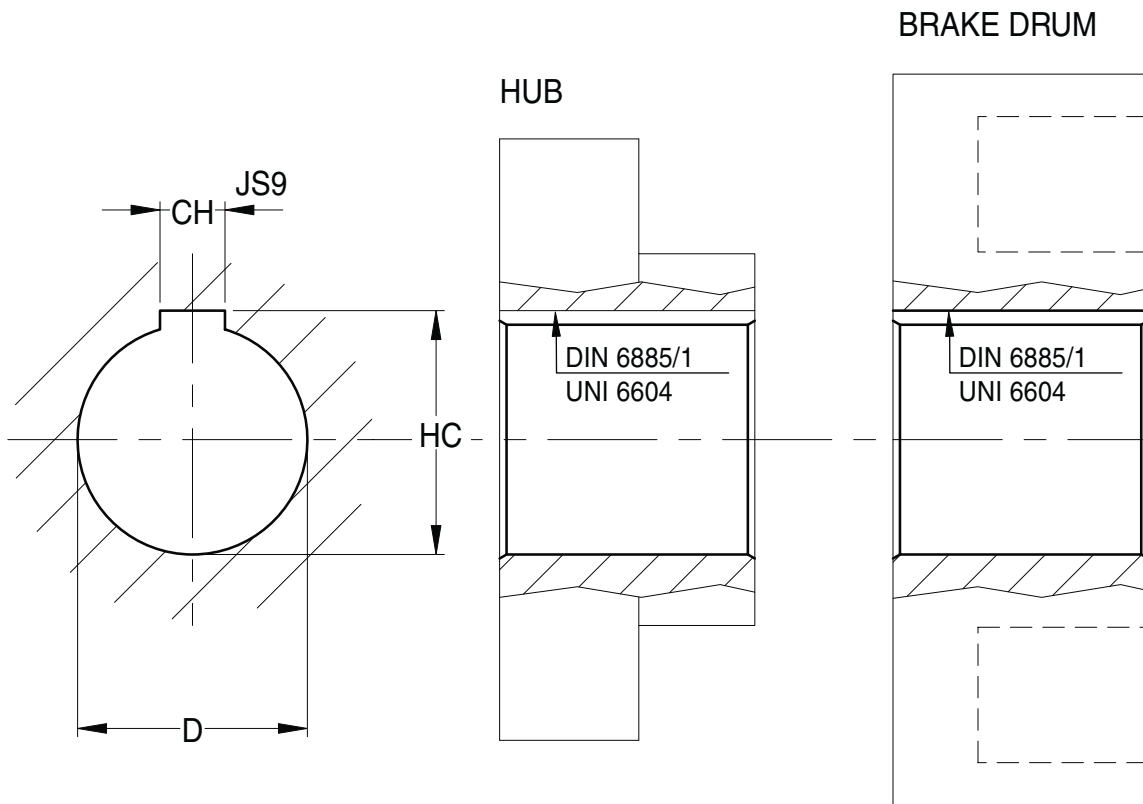

D	Toll.	CH	Toll.	HC	Toll.
10		3		11,4	
<b>11 *</b>		<b>4</b>		<b>12,8</b>	
12		4		13,8	
13		5		15,3	
<b>14 *</b>		<b>5</b>		<b>16,3</b>	+ 0,1
15		5		17,3	0
16		5		18,3	
17		5		19,3	
18		6		20,8	
<b>19 *</b>		<b>6</b>		<b>21,8</b>	
20	H7	6	JS9	22,8	
21		6		23,8	
22		6		24,8	
23		8		26,3	
<b>24 *</b>		<b>8</b>		<b>27,3</b>	
25		8		28,3	
26		8		29,3	
27		8		30,3	+0,2
<b>28 *</b>		<b>8</b>		<b>31,3</b>	0
30		8		33,3	
32		10		35,3	
33		10		36,3	
34	H7	10		37,3	
35		10		38,3	
<b>38 *</b>		<b>10</b>		<b>41,3</b>	

D	Toll.	CH	Toll.	HC	Toll.
40		12		43,3	
<b>42 *</b>		<b>12</b>		<b>45,3</b>	
45		14		48,8	
<b>48 *</b>		<b>14</b>		<b>51,8</b>	
50		14		53,8	
<b>55 *</b>		<b>16</b>		<b>59,3</b>	
<b>60 *</b>		<b>18</b>		<b>64,4</b>	
<b>65 *</b>		<b>18</b>		<b>69,4</b>	
<b>70 *</b>		<b>20</b>		<b>74,9</b>	
<b>75 *</b>		<b>20</b>		<b>79,9</b>	
<b>80 *</b>	H7	<b>22</b>	JS9	<b>85,4</b>	
<b>85 *</b>		<b>22</b>		<b>90,4</b>	
<b>90 *</b>		<b>25</b>		<b>95,4</b>	+0,2
95		25		100,4	0
<b>100 *</b>		<b>28</b>		<b>106,4</b>	
105		28		111,4	
<b>110 *</b>		<b>28</b>		<b>116,4</b>	
115		32		122,4	
120		32		127,4	
<b>125 *</b>		<b>32</b>		<b>132,4</b>	
130		32		137,4	
<b>135 *</b>		<b>36</b>		<b>143,4</b>	
140		36		148,4	
160		40		169,4	
180		45		190,4	

\* TYPICAL BORE SIZES

**OIL CHANGE:**

The oil in the coupling must be changed for the first time after 2000 working hours and subsequently after each 4000 working hours.

Proceed as follows to change the oil:

- 1) Rotate the coupling to bring the filling plug to its highest position.
  - 2) Unscrew and remove the filling plug.
  - 3) Determine the correct filling level by rotating the coupling until the filling hole corresponds to the current oil level.
  - 4) Completely drain the oil in the coupling by bringing the filling hole to its lowest point.
  - 5) Rotate the coupling again to bring the filling hole to correspond to the filling level determined at point 3.
  - 6) Pour in the new oil until the oil filling level is reached
- The quantity and type of oil recommended is listed in Table 1.

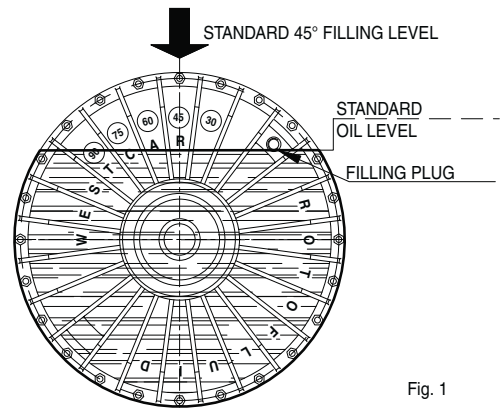

Fig. 1

**VARIATION OF THE OIL LEVEL (Figures 1 and 2)**

According to the type of use and the service required by the coupling, sometimes the oil filling level must be modified by increasing or decreasing the oil quantity.

The following results are achieved by decreasing the oil quantity:

- Slower and more gradual startings (Fig. 3).
- Less absorption of starting current.
- Better protection to the transmission elements in the event of overload.
- Higher slip value at running.

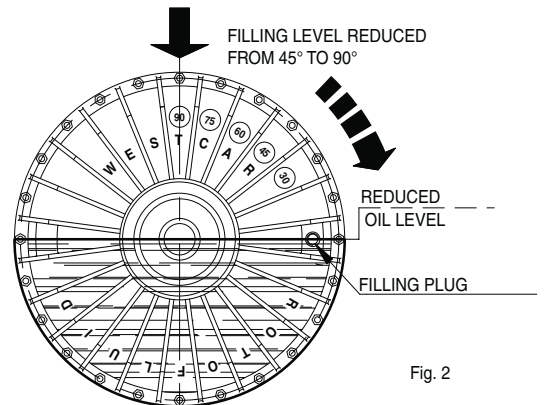

Fig. 2

**IMPORTANT:**

An excessive decrease in the oil quantity can cause the following problems:

- The impossibility of rapidly accelerating the machine due to insufficient torque.
- The overheating of the coupling, with consequent damage to the oil seals.

The following results are achieved by increasing the oil quantity:

- Faster startings (Fig. 3).
- Lower slip value at running.
- Higher absorption of starting current during acceleration phases.
- Greater strain on transmission elements.

**IMPORTANT:**

An excessive oil quantity can cause the following problems:

- The overloading of the electric motor.
- The overturning of the oil seal lip due to internal overpressure.
- The cracking of the coupling housing due to internal overpressure caused by the lack of internal space for sufficient oil expansion.

NOTE: the filling level at 45° must never be exceeded, and a level at 30° can be reached only in special cases and after previous WESTCAR consult.

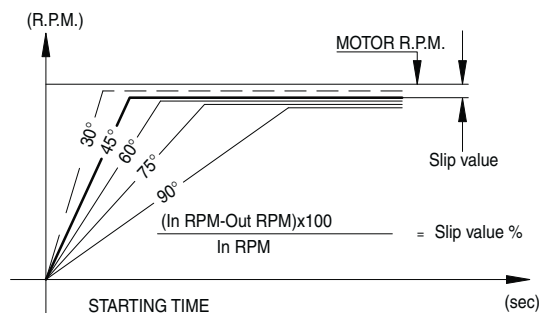

Fig. 3

**Tab. 1**

Types of oil recommended for standard working temperature from -20°C. to +180°C.

- BP ENERGOL HPL 22÷32
- CASTROL HYPIN AWS 22÷32
- ESSO SPINASSO 22÷32
- MOBIL VELOCITE OIL D
- OLEOTECNICA MOVO H 22÷32
- SHELL TELLUS OIL 22÷32

Types of oil can work continually (longer 5 days) working temperature from -15°C. to +180°C.

- BP ENERGOL HLP Z 46
- CASTROL HYPIN AWS 46
- ESSO NUTO H 46
- MOBIL DTE 25
- OLEOTECNICA MOVO H 46
- SHELL TELLUS 46

The coupling can be also supplied with fire-proof oil or for low temperature one (-40°C.). For more information, consult WESTCAR.

SIZE	OIL QUANTITIES CORRESPONDING TO DIFFERENT FILLING LEVELS									
	30°		45°		60°		75°		90°	
	Kg	Lt.	Kg	Lt.	Kg	Lt.	Kg	Lt.	Kg	Lt.
10	0,53	0,61	0,48	0,55	0,41	0,47	0,35	0,40	0,28	0,32
20	1,15	1,32	1,05	1,20	0,90	1,03	0,76	0,86	0,62	0,71
30	2,28	2,61	2,09	2,39	1,78	2,04	1,46	1,67	1,18	1,34
30P	3,88	4,43	3,55	4,05	3,02	3,46	2,48	2,83	1,98	2,27
40P	3,89	4,45	3,56	4,07	3,05	3,48	2,51	2,87	2,03	2,32
50	4,24	4,85	3,84	4,39	3,31	3,78	2,81	3,21	2,33	2,67
55	6,98	7,98	6,29	7,19	5,43	6,21	4,65	5,31	3,88	4,44
60	8,29	9,47	7,53	8,61	6,41	7,32	5,32	6,08	4,33	4,95
65	13,04	14,91	11,80	13,48	10,01	11,44	8,38	9,58	6,86	7,84
70P	16,83	19,23	15,42	17,62	13,18	15,07	10,8	12,34	8,68	9,92
75P	28,18	32,21	25,70	29,37	21,86	24,98	18,06	20,64	14,63	16,72
80P	34,03	38,89	31,09	35,53	26,63	30,43	22,03	25,18	17,92	20,48
85P	58,26	66,59	53,06	60,64	45,30	51,77	37,66	43,04	30,73	35,12
90P	86,83	99,23	80,43	91,92	69,76	79,73	56,31	64,35	44,68	51,06
95P	146,23	167,12	134,16	153,33	115,05	131,48	94,22	107,68	75,88	86,72
1200	199	226	176	200	156	177	132	150	110	125
1200/2	398	452	352	400	312	354	264	300	220	250

**OIL CHANGE:**

The oil in the coupling must be changed for the first time after 2000 working hours and subsequently after each 4000 working hours.

To change the oil, proceed as follows:

- 1) Rotate the coupling to bring the filling plug to its highest position.
- 2) Unscrew and remove the filling plug.
- 3) Determine the correct filling level by rotating the coupling until the filling hole corresponds to the current oil level.
- 4) Completely drain the oil in the coupling by bringing the filling hole to its lowest point.
- 5) Rotate the coupling again to bring the filling hole to correspond to the filling level determined at point 3.
- 6) Pour in the new oil until the oil filling level is reached.

The quantity and type of oil recommended is listed in Table 1.

**VARIATION OF THE OIL LEVEL (Figures 1 and 2)**

According to the type of use and the service required by the coupling, sometimes the oil filling level must be modified by increasing or decreasing the oil quantity.

The following results are achieved by decreasing the oil quantity:

- Slower and more gradual startings (Fig. 3).
- Less absorption of starting current.
- Better protection to the transmission elements in the event of overload.
- Higher slip value at running.

**IMPORTANT:**

An excessive decrease in the oil quantity can cause the following problems:

- The impossibility of rapidly accelerating the machine due to insufficient torque.
- The overheating of the coupling, with consequent damage to the oil seals.

The following results are achieved by increasing the oil quantity:

- Faster startings (Fig. 3).
- Lower slip value at running.
- Higher absorption of starting current during acceleration phases.
- Greater strain on transmission elements.

**IMPORTANT:**

An excessive oil quantity can cause the following problems:

- The overloading of the electric motor.
- The overturning of the oil seal lip due to internal overpressure.
- The cracking of the coupling housing due to internal overpressure caused by the lack of internal space for sufficient oil expansion.

NOTE: the filling level at 45° must never be exceeded, and a level at 30° can be reached only in special cases and after previous WESTCAR Consult.

Types of oil recommended for standard working temperature from -20°C. to +180°C.

- BP ENERCOL HPL 22÷32
- CASTROL HYPIN AWS 22÷32
- ESSO SPINASSO 22÷32
- MOBIL VELOCITE OIL D
- OLEOTECNICA MOVO H 22÷32
- SHELL TELLUS OIL 22÷32

Types of oil recommended for continuous work (over 5 days) temperature -15°C. to +180°C.

- BP ENERCOL HLP Z 46
- CASTROL HYPIN AWS 46
- ESSO NUTO H 46
- MOBIL DTE 25
- OLEOTECNICA MOVO H 46
- SHELL TELLUS 46

The coupling can be also supplied with fire-proof oil or for lowtemperature one (-40°C.). For more information, consult WESTCAR.

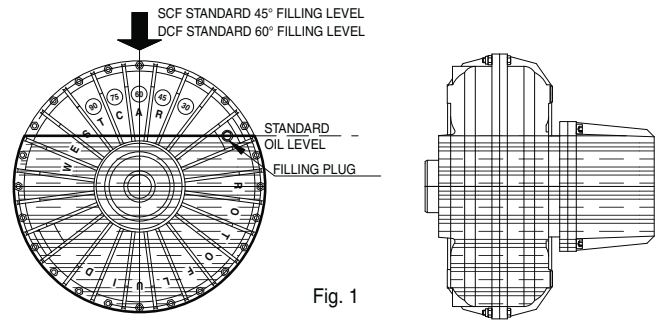

Fig. 1

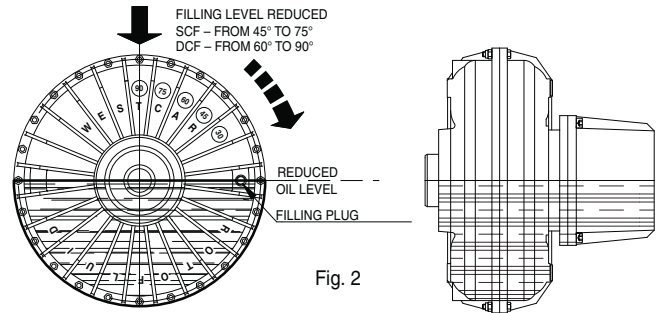

Fig. 2

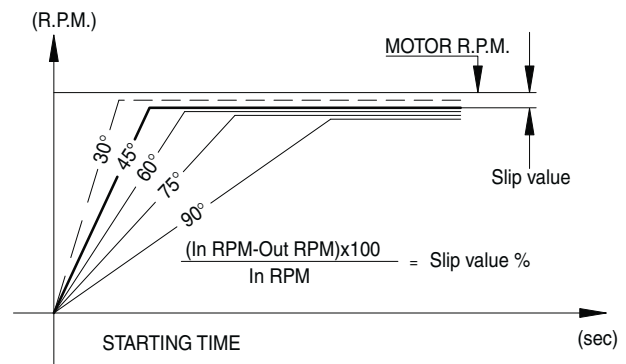

Fig. 3

Tab. 1

SIZE	OIL QUANTITIES CORRESPONDING TO DIFFERENT FILLING LEVELS							
	( Kg.= Litri x 0,875 )							
	45° (lt.)		60° (lt.)		75° (lt.)		90° (lt.)	
	SCF	DCF	SCF	DCF	SCF	DCF	SCF	DCF
20	-	-	-	-	-	-	-	-
30	2,65	2,94	2,30	2,58	1,86	2,07	1,47	1,61
30P	4,32	4,62	3,72	4,02	3,04	3,26	2,39	2,53
40P	4,44	5,34	3,84	4,70	3,14	3,78	2,45	2,93
50	5,27	6,36	4,62	5,67	3,83	4,59	3,07	3,56
55	8,06	9,12	7,04	8,05	5,93	6,67	4,84	5,33
60	10,01	11,63	8,71	10,35	7,16	8,41	5,58	6,29
65	14,86	16,42	12,80	14,34	10,65	11,85	8,47	9,20
70P	20,09	23,83	17,51	21,20	14,34	17,32	11,07	12,82
75P	32,96	36,68	27,39	31,02	22,61	25,55	17,87	19,63
80P	42,50	48,45	37,38	43,29	30,58	35,27	23,76	26,57
85P	67,55	73,49	59,54	64,49	48,40	53,08	38,41	41,22
90P	104,80	118,72	91,70	104,61	73,72	83,45	57,25	63,94
95P	178,18	192,94	154,89	168,50	125,43	135,76	98,63	105,81



In case of overheating, the fusible plug allows the oil out and thereby disconnects' the power transmitted to the output shaft.  
Fusible plugs are available for four different melting temperatures: 90°C, 120°C, 145°C and 180°C.  
The standard Couplings are supplied with fusible plug at 145° C.

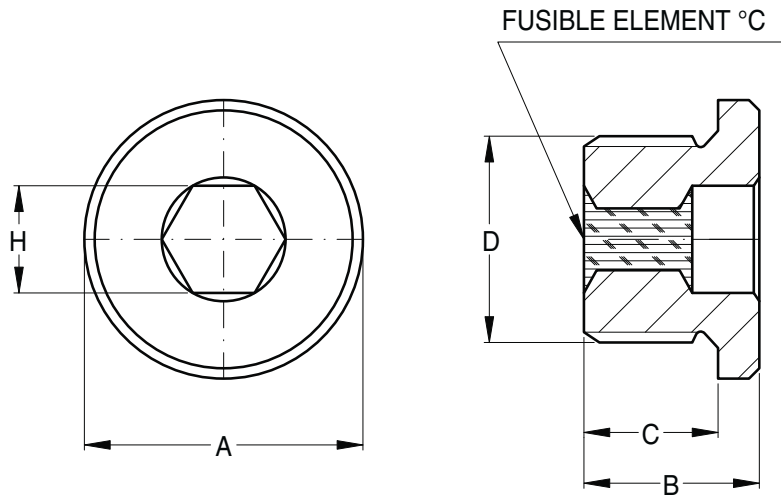

ROTOFLUID SIZE	PLUG DIMENSIONS					FUSIBLE ELEMENT TEMPERATURE AND COLOUR				WEIGHT Kg
	A	B	C	D	H	BLEU	WHITE	RED	GREEN	
10 20 30 30P 40P	18	15	11	¼ GAS	6	90°C	120°C	145°C	180°C	0,016
50 55 60 65 70P 75P 80P 85P	26	19	15	½ GAS	10	90°C	120°C	145°C	180°C	0,048
90P 95P	32	20	16	¾ GAS	12	90°C	120°C	145°C	180°C	0,075

When ordering specify: dimension "D", fusible plug melting temperature and colour.  
EX: Fusible plug \_ GAS 145° red.

**FUSIBLE PLUG STANDARD POSITION**

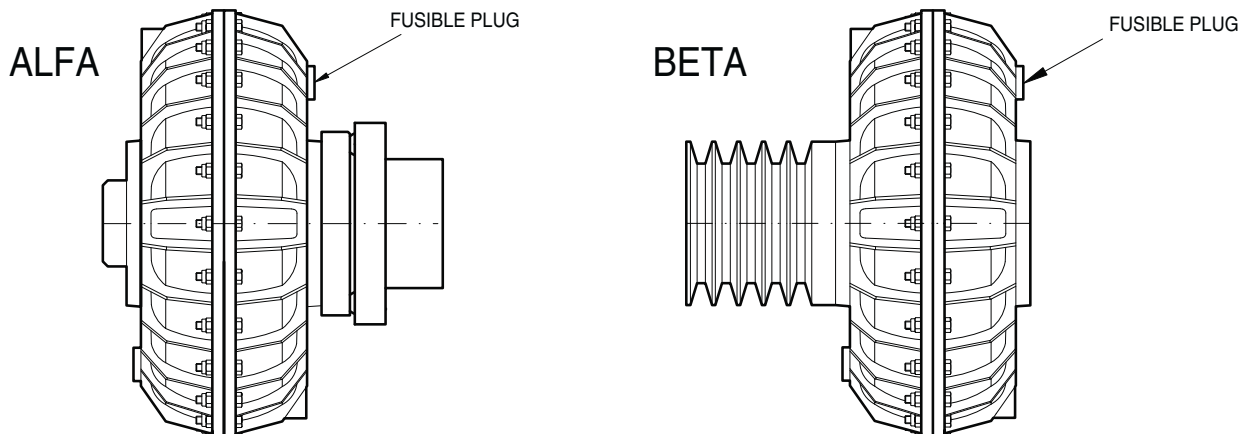

In case of coupling overheating with a thermal trip plug, a pin is released and trips a limit switch which activates an alarm or shuts' off the electric motor. This method avoids the oil leakage from the coupling.

Fusible trip plugs are available for four different temperatures: 90°C, 120°C, 145°C and 180°C.

In case of stall conditions, motor running and machine locked, the coupling housing must be driving to guarantee the signal survey.

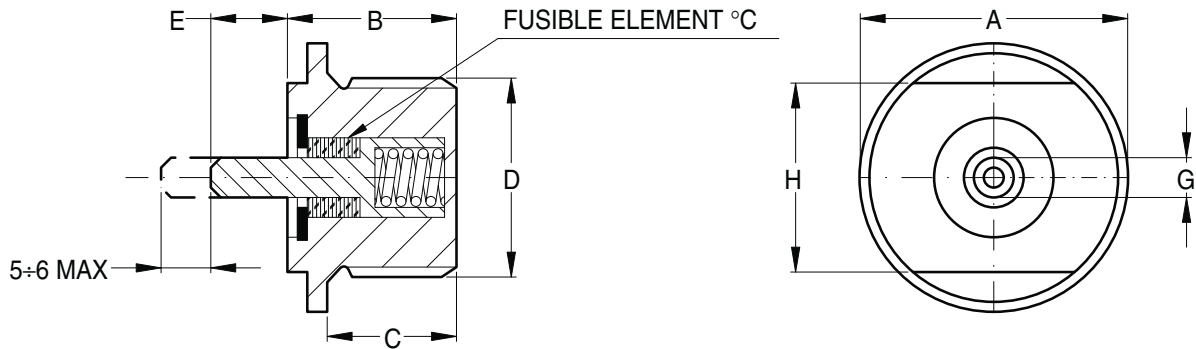

ROTOFLUID SIZE	PLUG DIMENSIONS							FUSIBLE ELEMENT TEMPERATURE AND COLOUR				Weight Kg
	A	B	C	D	E	G	H	BLEU	WHITE	RED	GREEN	
10 20 30 30P 40P	18	19	16	¼ GAS	8	4	14	90°C	120°C	145°C	180°C	0,016
50 55 60 65 70P 75P 80P 85P	26	19	15	½ GAS	8	4	19	90°C	120°C	145°C	180°C	0,048
90P 95P	32	20	16	¾ GAS	8	4	22	90°C	120°C	145°C	180°C	0,075

When ordering specify: dimension "D", safety plug melting temperature and colour.

EX: Fusible trip plug ¼ GAS 145° red.

**THERMAL TRIP PLUG STANDARD POSITION**

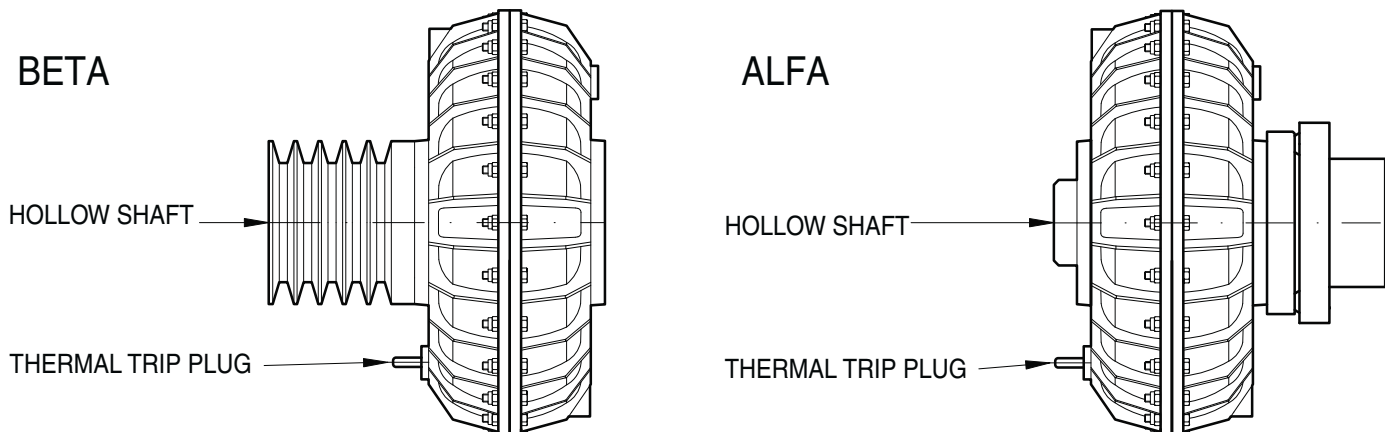

The thermal trip plug is normally mounted by the hollow shaft side but in case of need can be located in the opposite side too.

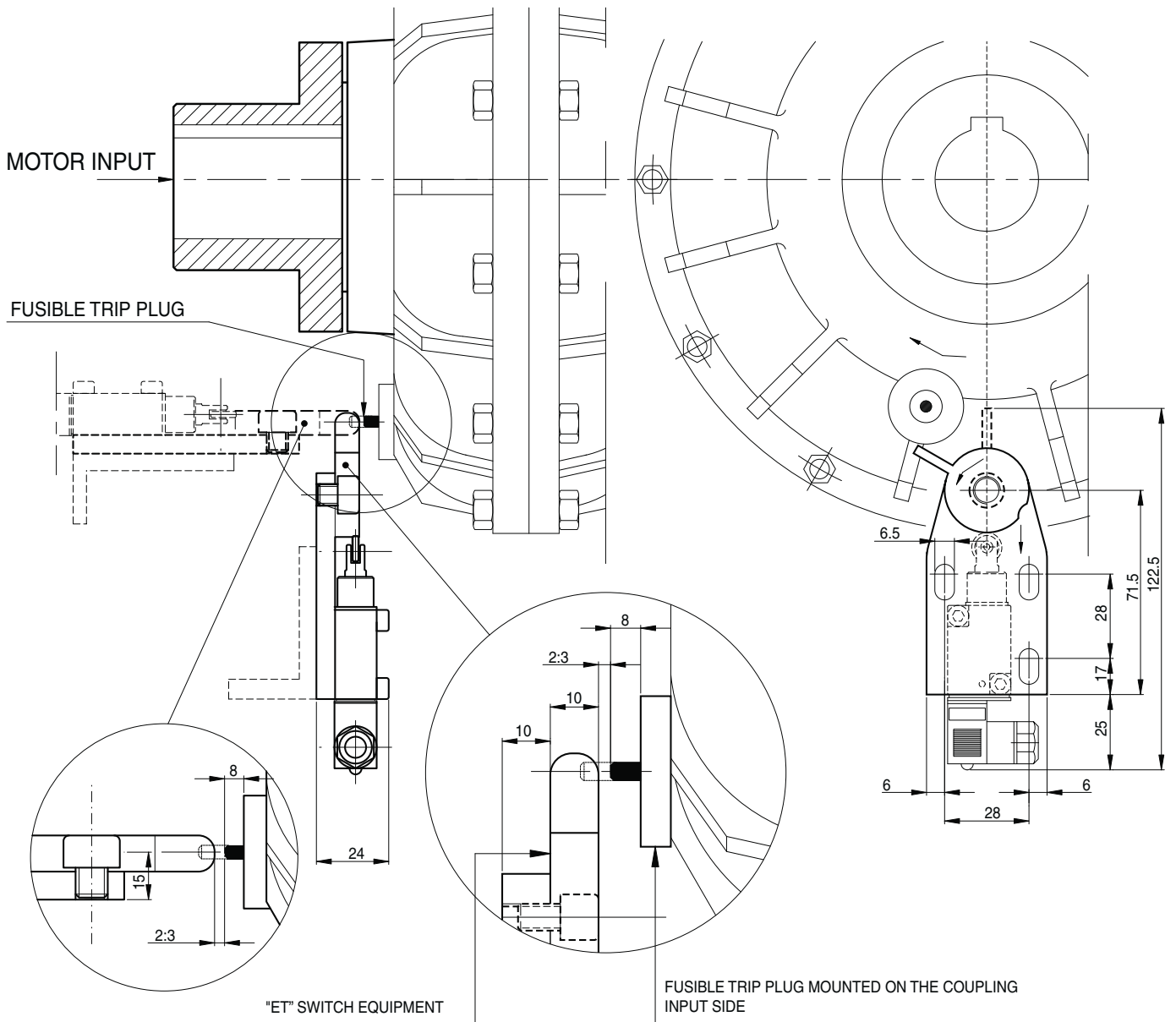

**"ET" CONNECTED TO A LIGHT OR SOUND SIGNAL**

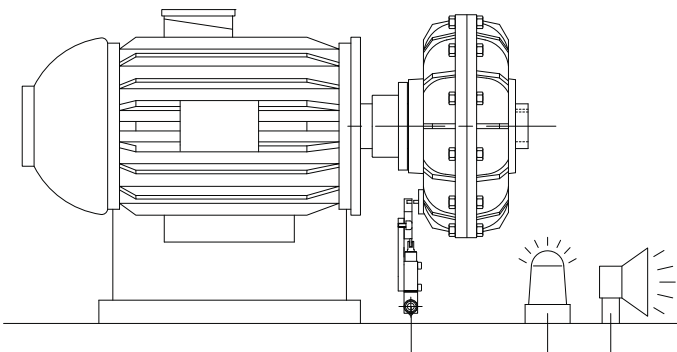

**"ET" CONNECTED TO SWITCH OFF THE DRIVE**

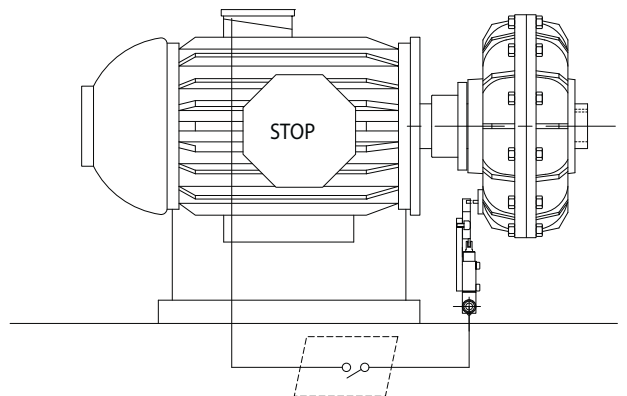

The "ET" safety device consists of a microswitch and a cam mounted on a base and operates in combination with a thermal trip plug fitted on the fluid coupling housing. In case of coupling overheating due to overloads and machine jams or reduced oil filling, the oil temperature can exceed the melting temperature set for the thermal trip plug. The pin then extends and makes contact with the cam of the microswitch sounding an alarm or shutting down the drive.

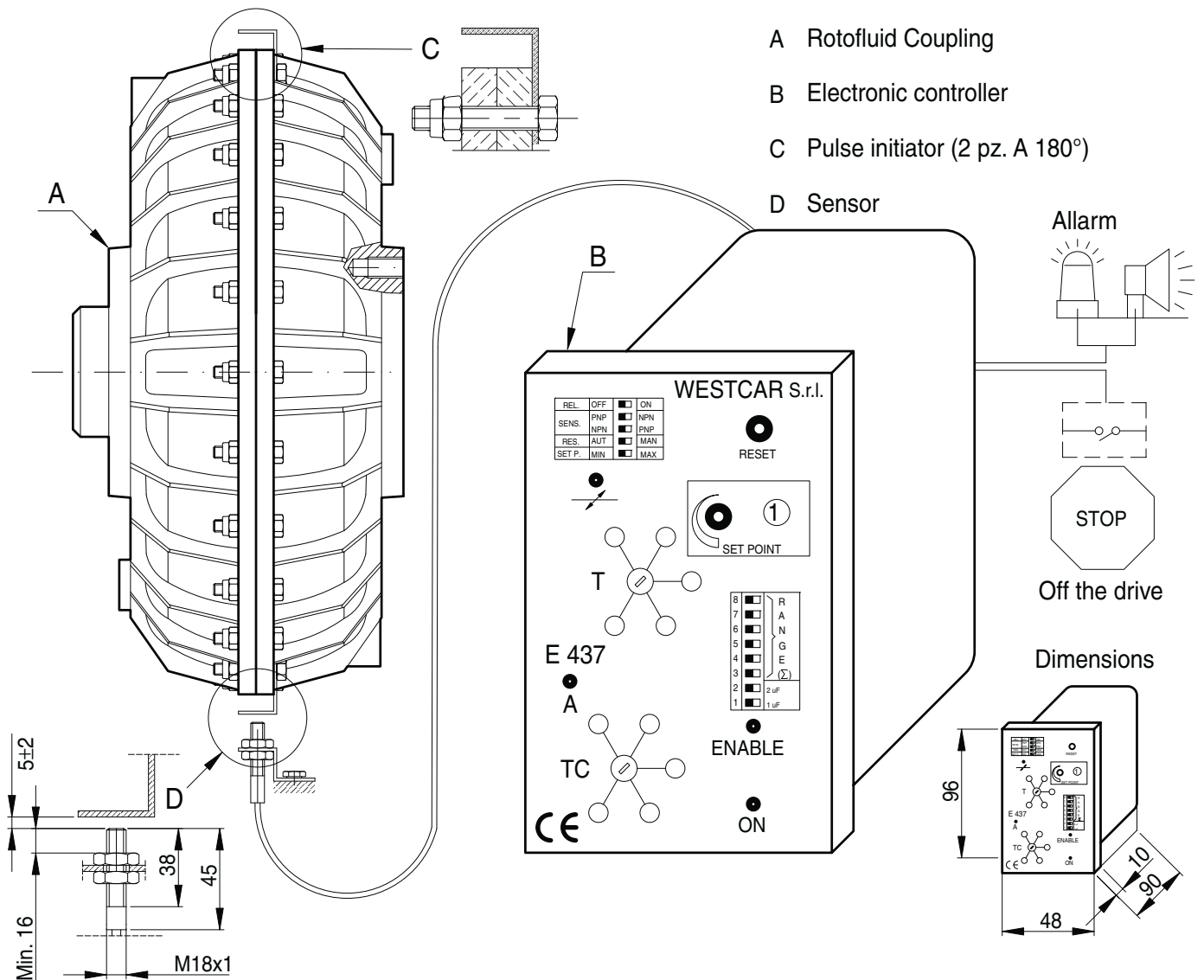

### "SCD" DEVICE

The "SCD" Device can be fitted to guarantee the safety of coupling and machine and the product quality.

The "SCD" device is an electronic controller which receives a train of pulses by a sensor. The pulses are converted into a voltage proportional to the pulses frequency. This voltage is compared with a variable reference voltage (SET POINT). The internal relay changes over when the input speed is faster or lower than the fixed (SET POINT). It is employed to control the shaft revolution speed. In case of speed decrease, the device gives a signal to the operator.

### OPERATION

As the transmitted torque is increased, this gives rise to an increased slip of the fluid coupling. Possible overload can be detected by measuring the resulting speed reduction in the driven half coupling by means of overload "SCD". This with change-over contact at the output may either emit an alarm signal or switch off the main motor. A delaying action (max 120 sec.) prevent the unnecessary triggering of the relay, when the motor is started. It only occurs once when the operating voltage is applied. False alarms are prevented arising from very short torque fluctuations, by the introduction of a preset time lag (max. 30 sec.)

### SUPPLY

50±60 Hz - Tolerance: -10%÷+6% - 24Vac STANDARD (115Vac or 230 Vac on request)- How to order: SCD 24 Vac

**TAPPED HOLE DIMENSIONS FOR STANDARD ELECTRIC MOTOR SHAFTS**

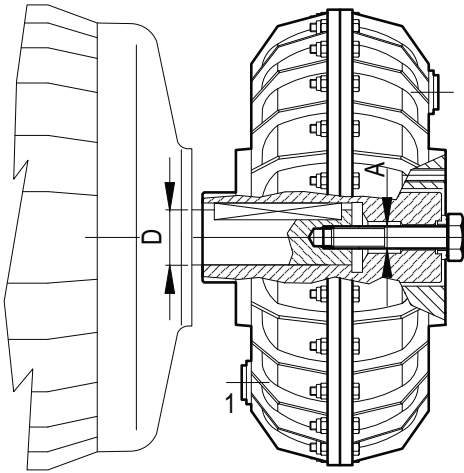

Dimensions "A"	MOTOR SHAFT DIAMETERS "D"									
	Ø 14	Ø 19	Ø 24	Ø 28	Ø 38	Ø 42 Ø 48	Ø 55 Ø 60 Ø 65 Ø 70 Ø 75 Ø 80	Ø 90 Ø 100 Ø 110 Ø 125 Ø 135	Ø 140 Ø 160	
M 5	●									
M 6		●								
M 8			●							
M 10				●						
M 12					●					
M 16						●				
M 20							●			
M 24								●		
M 36									●	

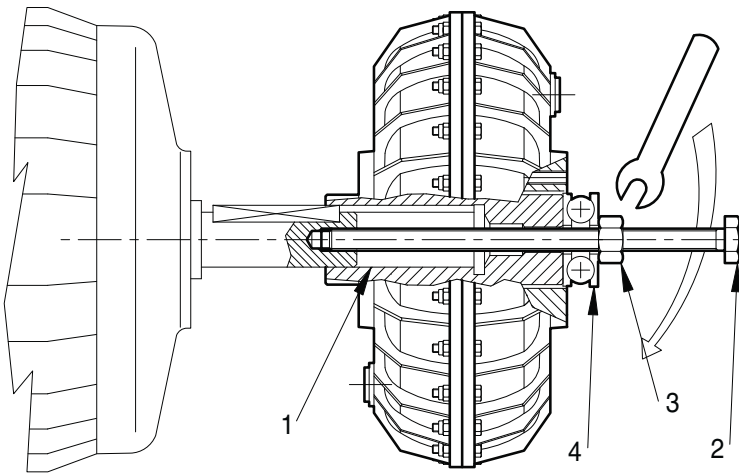

Fig. 1

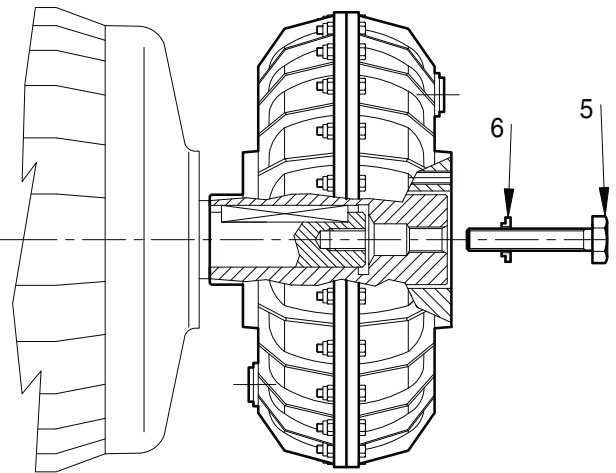

Fig. 2

For the mounting of the ROTOFUID coupling to the motor it is required to operate on the shaft (1) of the coupling to avoid axial stress on the bearings. It is recommended to fix on the motor shaft a screw stay (2) on which a nut (3) is tightened possibly resting to a thrust bearing (4) (see Fig.1).

It is indispensable to lubricate the motor shaft before mounting the coupling.

Check that the coupling shaft rest on the motor shaft shoulder and lock by means of screw (5), spacer (6) (see Fig.2)

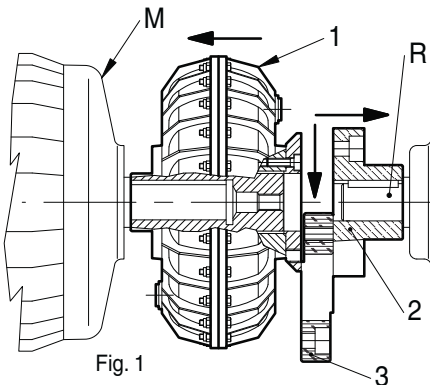

Fig. 1

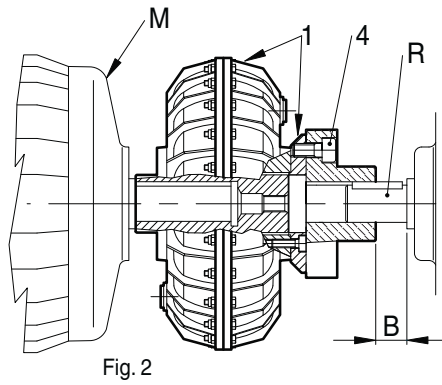

Fig. 2

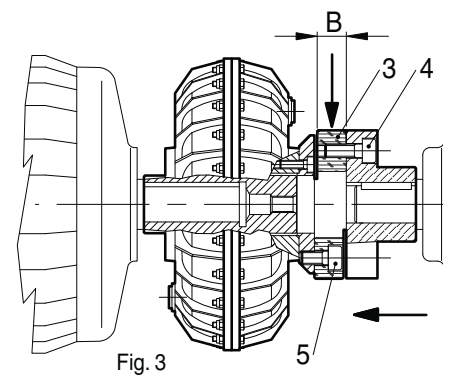
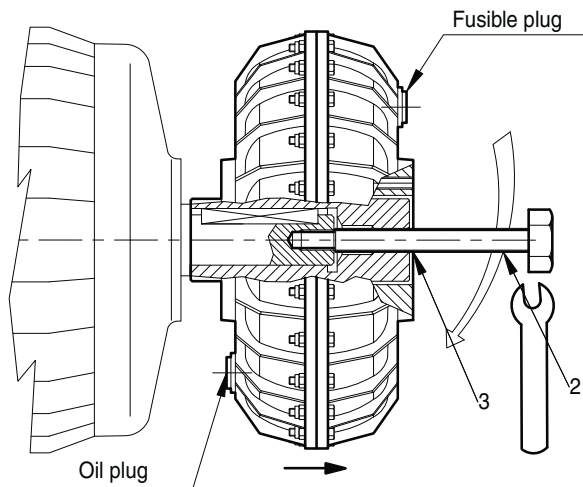

Fig. 3

- 1) Demount the ROTOFLEXI rubber element (3) as shown at Fig.1
- 2) Fit the ROTOFUID hydraulic coupling (1) on the motor shaft (M), fit the ROTOFLEXI hub (2) on the driven shaft (R). Assure that the driven shaft is coaxial with the hydraulic coupling (1). The concentricity is assured when it is possible to fix the hub (2) to the hydraulic coupling flange (1) by means of the screw (4), as shown at Fig.2. It is now possible to fix definitely the motor and the driven machine checking that between the hub (2) and the driven shaft shoulder there must be a gap (B) equal to the thickness of the rubber element (3).
- 3) Remove the screws (4), move the hub (2), place the rubber element (3), lock the screws (4) and (5) as shown at Fig.3.

**SCREW PULLER "VE" TYPE**



- To pull off the ROTOFUID coupling proceed as follows:
- Remove the screw plug or the tightening screw from the shaft end.
- Tight the screw puller in the shaft threaded hole checking that the motor shaft is locked.

ROTOFLUID COUPLING		
SYSTEM	SIZE	TYPE
"VE"		K
VE M14	20	K1
VE M16	20	K3
VE M20	20	-
VE M24	30	All versions
	30P	
	40P	
	50	
VE M30	55	Up to Ø 65 For Ø75 Ø 80
	60	All versions
VE M36	65	
	70P	
	75P	
	80P	
	85P	
	90P	
	95P	

**PULLING OFF SYSTEM "SE" TYPE**

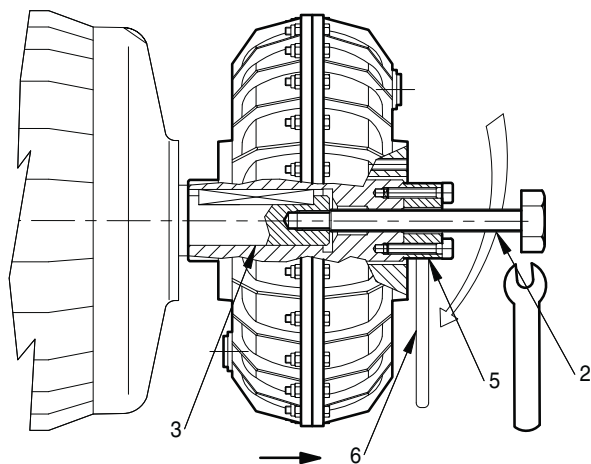

- To pull off the ROTOFUID coupling proceed as follows:
- Remove the screw plug or the tightening screw from the shaft end.
- Lock the bush (5) to the shaft end (3) with 2 securing screws.
- Tight the screw puller (2) in the shaft threaded hole keeping locked the rod (6) to avoid the motor shaft rotation.

ROTOFLUID COUPLING						
SYSTEM "SE"	SIZR	TYPE				
		K	Z	J	H	X
SE M20	20	-	-	J 103	H 85	X 103
SE M24/35	30	All versions				
	30P					
	40P					
	50					
SE M24/40	55	Up to Ø 65				
	55	For Ø75 Ø 80				
SE M30	60	All versions				
	65					
SE M36	70P					
	75P					
	80P					
	85P					
	90P					
	95P					

**PULLING OFF SYSTEM "SE" TYPE**

The figure 1 shows ROTOFUID® coupled in line with ROTOFLEX®. This kind of assembly permits the great advantage to replace the rubber elements without moving the transmission components from their position (Fig.2)

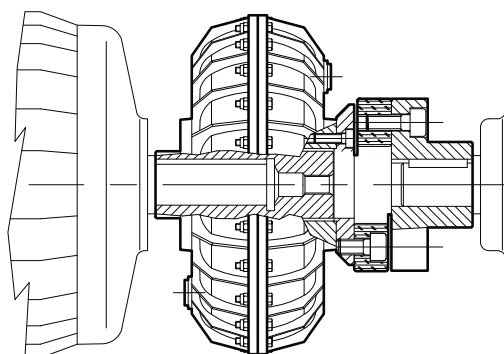

**Fig. 1**

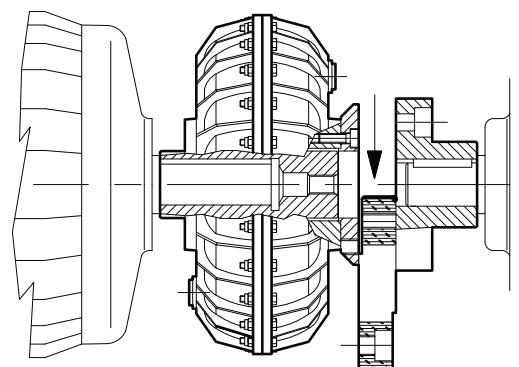

**Fig. 2**



**ROUND SINGLE IMPELLER COUPLINGS**

**COUPLING ALFA**

- 10 K1
- 20 K1
- 30 K1
- 30P K1
- 40P K1

Fig. 1

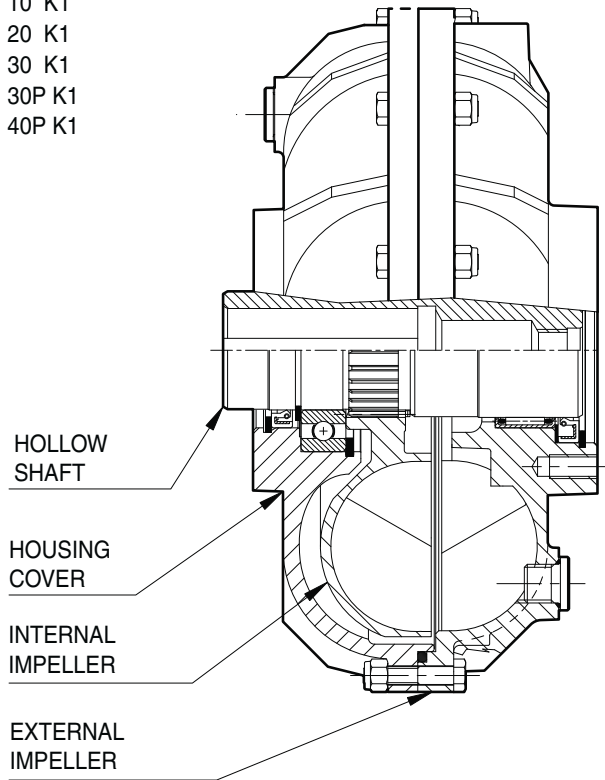

**COUPLING ALFA**

- 10 K3
  - 20 K3
  - 30 K3
  - 30P K3
  - 40P K2
- COUPLING BETA**
- 10 Z
  - 20 Z
  - 30 Z-X-J-H
  - 30P Z-X-J-H
  - 40P Z-X-J-H

Fig. 2

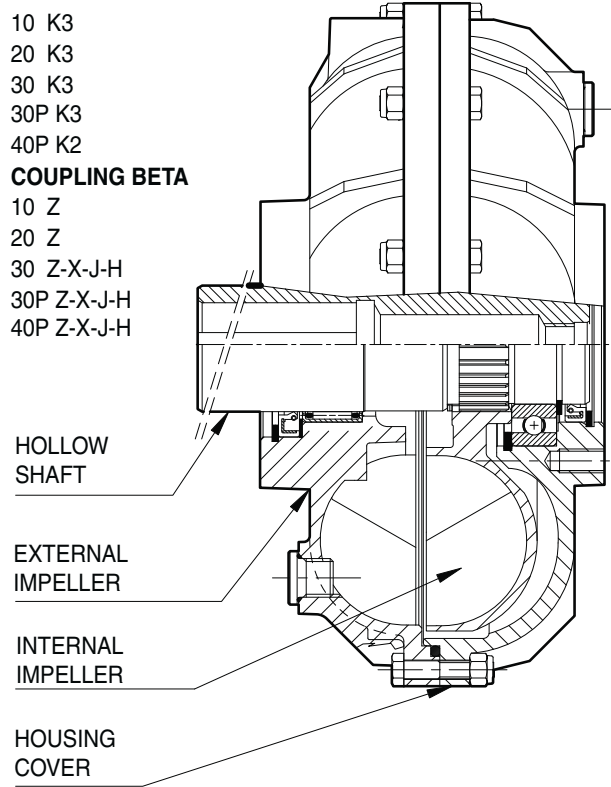

**SINGLE IMPELLER COUPLINGS**

Fig. 3

**COUPLING ALFA**

- 50 K2
- 60 K2
- 70P K2
- 80P K2
- 90P K2

**COUPLING BETA**

- 50 Z-X-J-H
- 60 Z-X-J-H
- 70P Z-X-J-H
- 80P Z-X-J-H

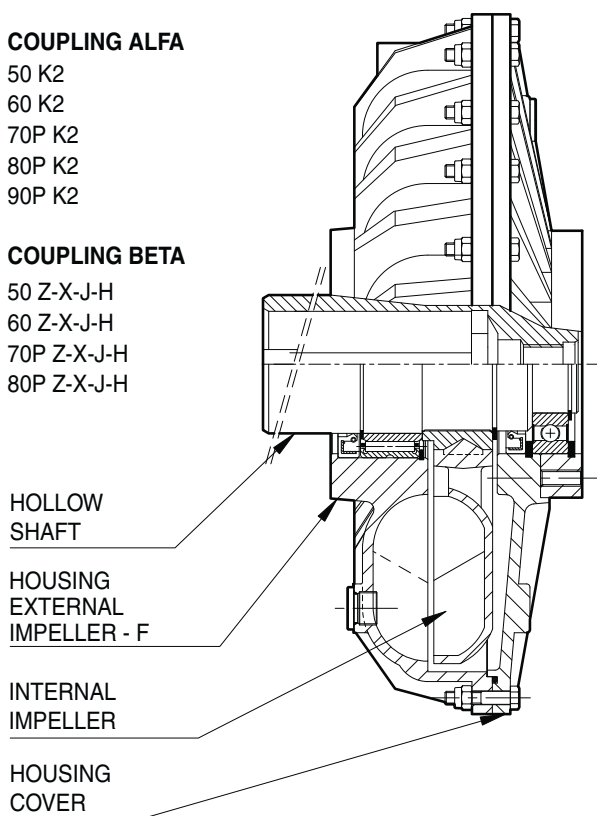

**TWIN IMPELLER COUPLINGS**

Fig. 4

**COUPLING ALFA**

- 55 K2
- 65 K2
- 75P K2
- 85P K2
- 95P K2

**COUPLING BETA**

- 55 Z-X-J-H
- 65 Z-X-J-H
- 75P Z-X-J-H
- 85P Z-X-J-H

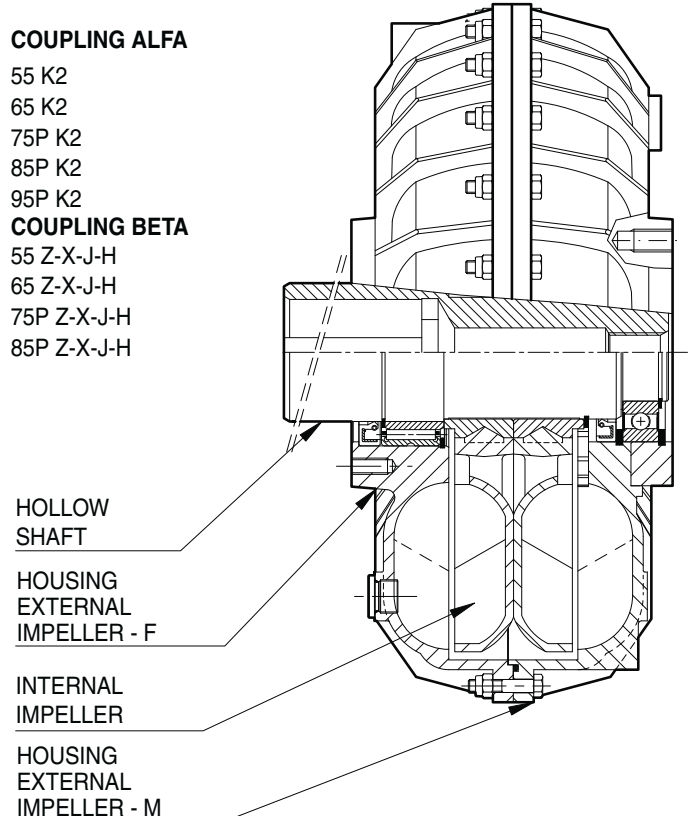



ROTOFLUID  
COUPLING

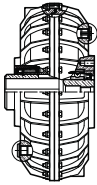

ROTOFLUID SCF  
COUPLIG

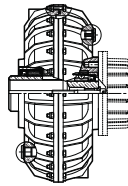

ROTOFLUID DCF  
COUPLING

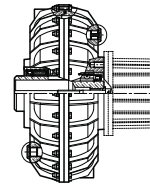

**SPARE PARTS FOR ALFA AND BETA COUPLINGS**

**1 OILSEALS KIT**

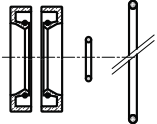

**2 BEARINGS KIT**

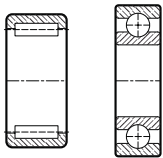

**3 SEEGER RINGS KIT**

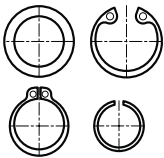

**4 NUTS KIT**

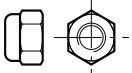

**5 OIL PLUG AND SCREWS KIT**

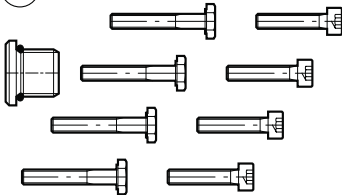

**6 FUSIBLE PLUG (1)**



(1) QUOTE TEMPERATURE  
90 °C - 120 °C - 145 °C - 180 °C

**7 THERMAL TRIP PLUG (1)**



(1) QUOTE TEMPERATURE  
90 °C - 120 °C - 145 °C - 180 °C

**ALFA COUPLING AND FLEXIBLE COUPLING**

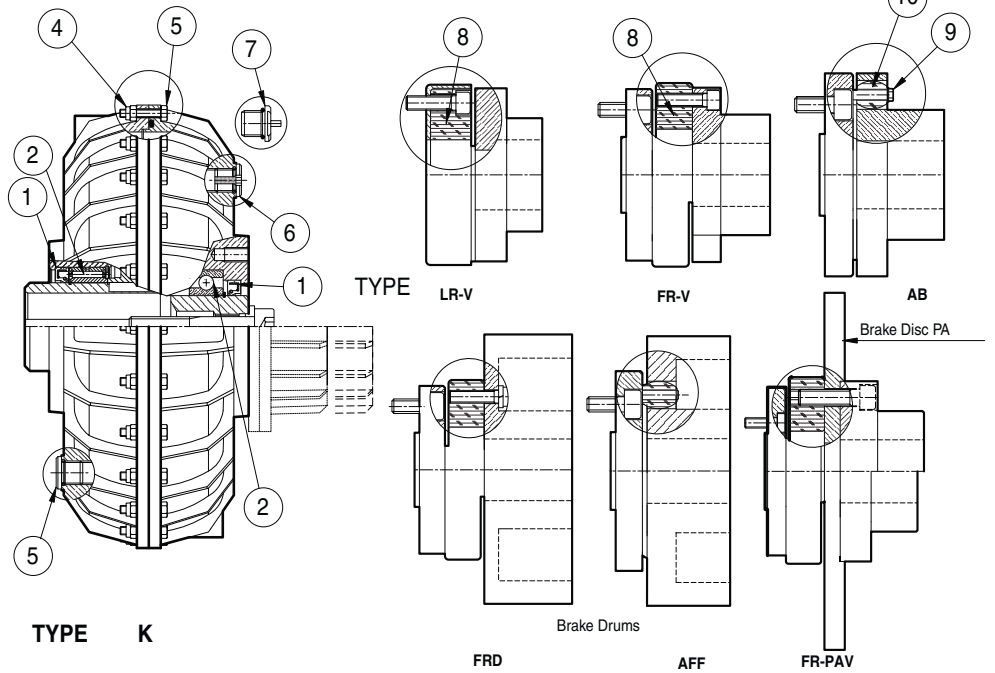

**BETA COUPLING**

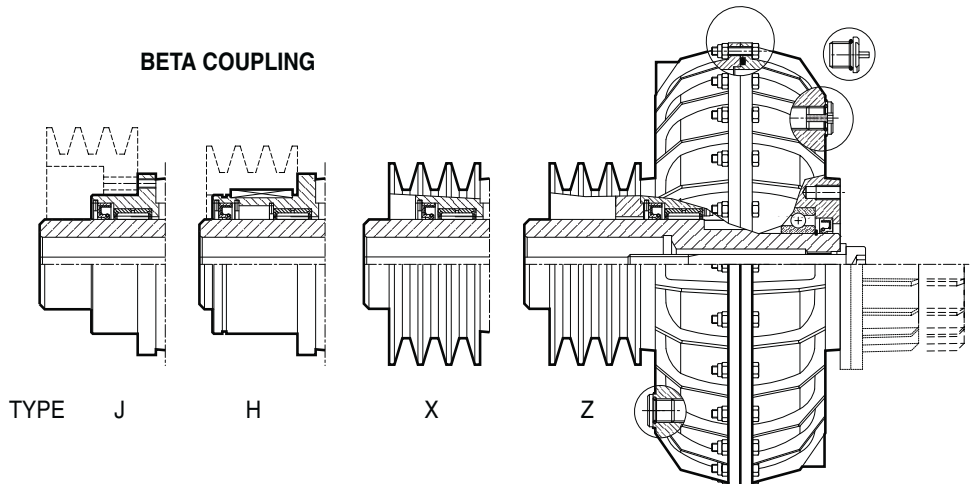

**SPARE PARTS FOR FLEXIBLE COUPLING**

**8 FLEXIBLE COUPLING WITH SCREW**



FOR ROTOFLEXI  
COUPLINGS

LRV  
FRV  
FRD  
FR-PAV

**9 PINS WITH RUBBER**

FOR ROTOPIN COUPLINGS  
AB  
AFF

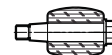

**10 RUBBER BUFFER**

FOR ROTOPIN COUPLINGS  
AB  
AFF



For transmission oil characteristic see installation and maintenance manual.  
To order spare parts indicate coupling type and identification code or see pag.3 of instruction manual.

THE OPTIONAL FUNCTIONS  
WILL MODIFY THE BASIC  
CODE OF THE  
STANDARD COUPLING

ROTOFLUID COUPLING

OPTIONAL FUNCTIONS

SIZE	VERSION	HOLE
		BORE D

HORIZONTAL SHAFT  
MOUNTING

VERTICAL SHAFT MOUNTING  
MOTOR SHAFT UP WARDS

VERTICAL SHAFT MOUNTING  
MOTOR SHAFT DOWN WARDS

OIL FILLING PLUG PARALLEL  
TO THE COUPLING SHAFT

OIL FILLING PLUG RADIAL  
TO THE COUPLING SHAFT

**NBR** OIL SEALS FOR MAX. 120°C  
(WITHOUT STRENGTHENING RINGS)

**VITON** OIL SEALS FOR  
MAX 200°C

STRENGTHENING AND PROTECTING  
RINGS FOR OIL SEALS

OIL FOR TEMPERATURES FROM  
-20°C TO +180°C.  
NONFLAMMABLE OIL (I)  
OIL FOR TEMPERATURES FROM  
-40°C TO +160°C (B)

BEARINGS LUBRICATION WITH  
TRANSMISSION OIL

FORCED BEARINGS LUBRICATION  
WITH GREASE/OIL

COUPLING ARRANGED FOR  
DISASSEMBLING WITH EXTRACTION  
SCREW

COUPLING ARRANGED FOR  
DISASSEMBLING WITH  
"S.E." SYSTEM (E)

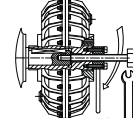
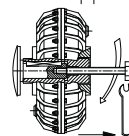
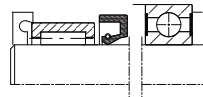
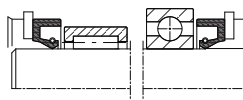
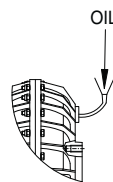
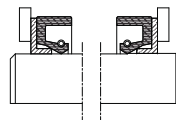
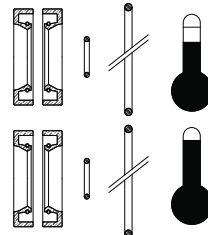
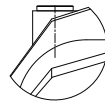
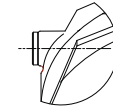
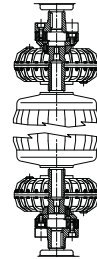
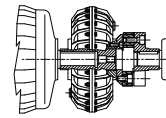

Standard

C1

C2

Standard

R

C1 Standard

V

ZZ

Standard

I

B

Standard

G

Standard

E



**FIELDS OF APPLICATION**

**Building-Construction-Surface Mining-Bricks**

- Tower cranes
- Bridge cranes
- Belt conveyors
- Armored chain conveyors
- Screw conveyors
- Slat conveyors
- Bucket wheel excavators
- Bucket elevators
- Concrete mixers
- Rotating screens
- Rolling mills
- Brick moulders
- Power trowels
- Stone crushers
- Centrifuge for concrete piles
- Hammer and barrel mills

**Textile**

- Drum tumblers
- Centrifuges
- Industrial washing machines
- Driers
- Carding machines
- Spinning machines
- Combing machines
- Raising machines

**Chemical – Foodstuff**

- Centrifuges
- Centrifugal separators
- Decanters
- Rotating filters
- Mixers
- Stirrers
- Soap cutters
- Bottling plants
- Disc driers
- Waste slaughterhouses braker

**Mechanical Engineering**

- Twisting machines for rope and wire
- Rod iron straighteners
- Presses
- Profiling machines
- Drawbenches
- Cutters

**Automotive Industry**

- Balancing machines
- Tow conveyors
- Overhead chain conveyors
- Gates open/closing drive
- Chain conveyors
- Car parking elevators

**Paper Processing**

- Winders
- Pulpers
- Cardboard making machinery
- Mixers

**Timber Processing**

- Drum barkers
- Hardboard presses
- Shredders
- Plywood presses

**Plastic and Rubber**

- Crushers
- Screw extruders
- Calenders
- Rolling presses
- Mixers
- Muddlers

**Cement Mill**

- Rotating kilns
- Belt conveyors
- Bucket elevators
- Fan blowers

**Marble**

- Gantry cranes
- Multi-blade frames
- Diamond wire saw

**Ceramics**

- Continuous and intermittent ball mills
- Mixers
- Presses

**The Ecology**

- Blenders
- Sludge purification plant

**Others**

- Winches
- Windlasses
- Centrifugal and alternative compressors
- Suction and centrifugal fans
- Centrifugal pumps
- Fire pumps
- Elevators
- Cable cars
- Amusements park rides
- Haulage wagons in steelworks and mines
- Stack-up coating plants
- Sprayers
- Refineries
- Ski lift
- Sand mixers



# APPLICATIONS



Elevator winch



Rotating dryer

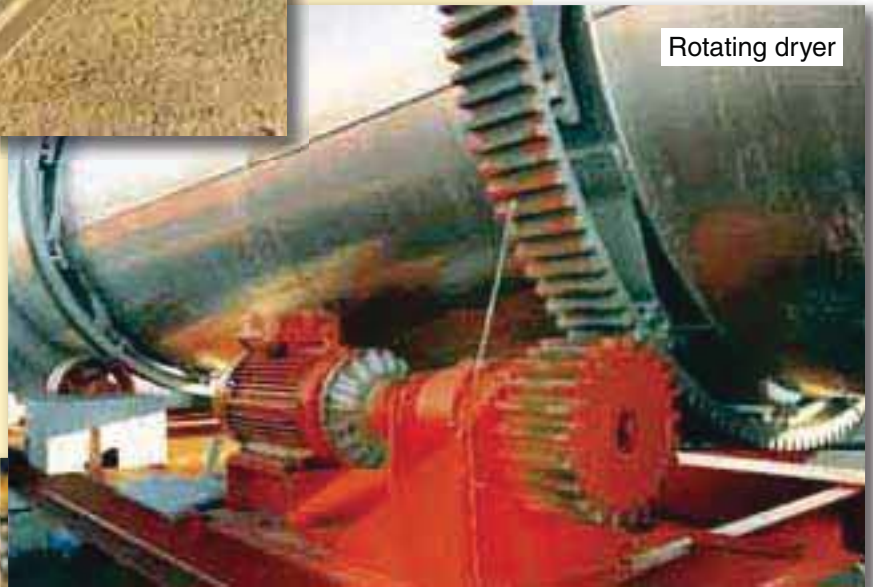

Shredder



Belt conveyor

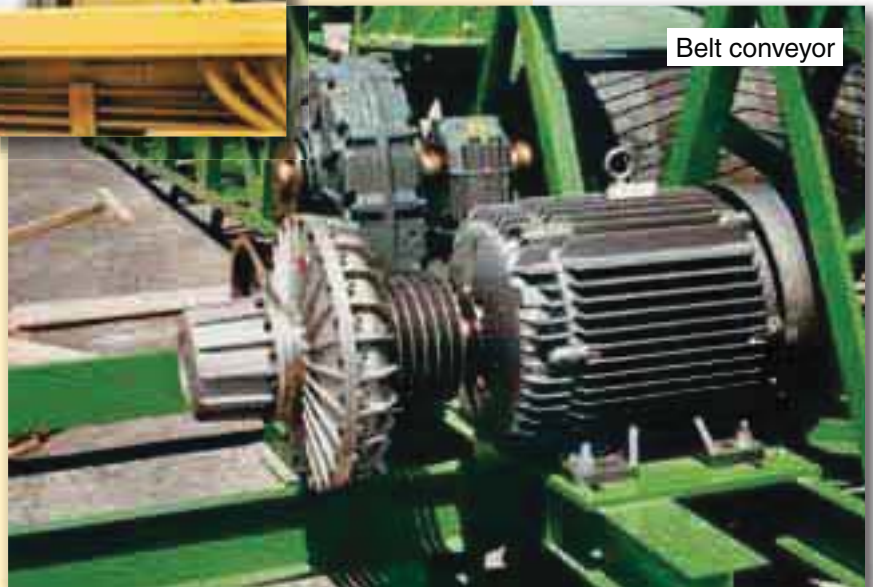



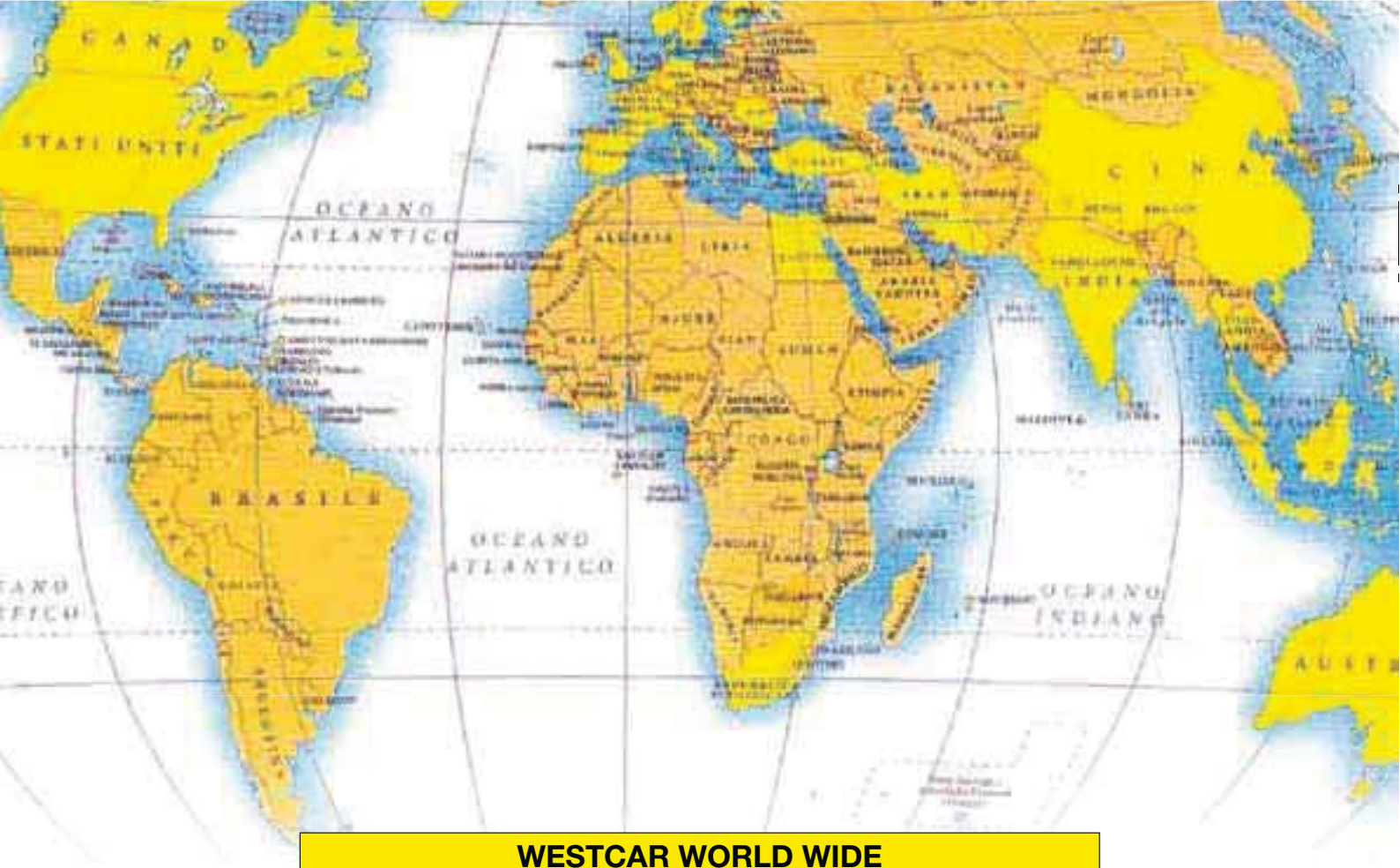

**WESTCAR WORLD WIDE**

- |   |  |                                       |
|---|--|---------------------------------------|
| <input type="checkbox"/> Australia        | <input type="checkbox"/> Great Britain | <input type="checkbox"/> Romania      |
| <input type="checkbox"/> Austria          | <input type="checkbox"/> Holland       | <input type="checkbox"/> Singapore    |
| <input type="checkbox"/> Belgium          | <input type="checkbox"/> Hungary       | <input type="checkbox"/> Slovenja     |
| <input type="checkbox"/> Canada           | <input type="checkbox"/> India         | <input type="checkbox"/> South Africa |
| <input type="checkbox"/> Ceka Republik    | <input type="checkbox"/> Indonesia     | <input type="checkbox"/> Spain        |
| <input type="checkbox"/> China - Shanghai | <input type="checkbox"/> Iran          | <input type="checkbox"/> Sweden       |
| <input type="checkbox"/> Cyprus           | <input type="checkbox"/> Israel        | <input type="checkbox"/> Switzerland  |
| <input type="checkbox"/> Denmark          | <input type="checkbox"/> Korea         | <input type="checkbox"/> Taiwan       |
| <input type="checkbox"/> Egypt            | <input type="checkbox"/> Malaysia      | <input type="checkbox"/> Thailand     |
| <input type="checkbox"/> Finland          | <input type="checkbox"/> New Zealand   | <input type="checkbox"/> Turkey       |
| <input type="checkbox"/> France           | <input type="checkbox"/> Norway        | <input type="checkbox"/> U.S.A.       |
| <input type="checkbox"/> Germany          | <input type="checkbox"/> Portugal      |                                       |

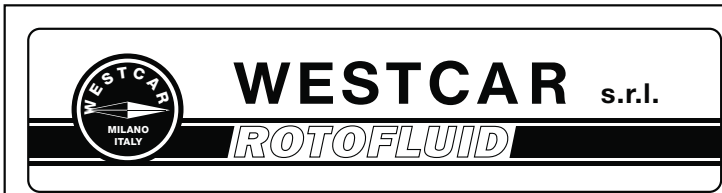

Distributor

**WESTCAR s.r.l.** Via Monte Rosa, 14 - 20149 MILANO (Italy)  
 Tel. +39 02.76.11.03.19 r.a. - Fax +39 02.76.11.00.41  
 E-mail: info@westcar.it - www.westcar.it