

Hydraulically piloted check valves type HRP

with/without hydraulic pre-relief
manifold mounting

Operating pressure p_{max} = 700 bar

Flow Q_{max} = 400 lpm

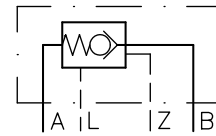

1. General information

These valves enable free flow in the one direction but prevent it in reverse direction when the hydraulic release is not actuated either via an external control line or internally via a directly mounted directional seated valve type G..(W..) 3-0 B 0,4 acc. to D 7300 or type WH 1 H(M) acc. to D 7470 A/1. The check valves feature a ball seated design, are made completely made of steel and are suited for mounting onto customer furnished manifolds.

Versions

- Valves without hydraulic pre-relief,
open the full flow cross section area rather quickly when released. They are suited for all standard operation conditions. A throttling section in the control port dampens the switching movement of the releasing piston, which effectively suppresses pressure surges in most cases. When pressure surges show up during initial operation they can be eliminated by installation of an additional orifice which will reduce the opening speed even more (see sect. 3.3).
- Valves with hydraulic pre-relief,
are more suitable for high pressure and larger consumer volumes. A small ball type check valve located in the spherically ground main valve spool, opens up a small annular gap just prior to the main passage is opened, thereby acting like a throttle enabling a bumpless decompression. The effectiveness of this pre-relief i.e. the smoothness of the decompression depends directly on the open-up speed of the control piston. There is a slight leakage between control port Z and leakage port L, because of the missing control piston sealing at type HRP7V. An additional orifice (see sect. 3.3) installed in the control line may be found advantageous in some cases.

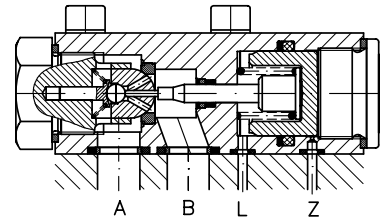
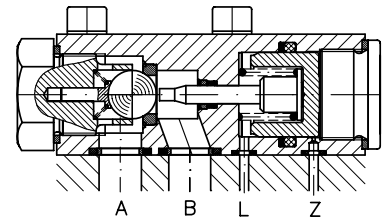

Application

- Blockage of zero-leakage cylinders when used together with leakage prone directional spool valves
- Return flow relief for directional valves during retraction of double acting cylinders
- 2/2-way directional seated valve with hydraulic actuation

2. Available versions, main data

Order examples:

HRP 2 - B 0,4

Optional orifice in the control port Z (see sect. 3.2)

HRP 7V - X

Table 3: Additional control port X, G 1/4 DIN ISO 228/1 (BSPP) (HRP 7V.. only!)

HRP 4V - WG 3-0 B 0,4 - WG 230

Type HRP 7V: without port X
 HRP 7V - X: with blanking plate and tapped plug
 HRP 7V - GZ 3-1 B 0,6 - G 24: port X not plugged

Table 2: Optional 3/2-way directional seated valve, directly mounted

For mounting at	HRP shows free flow, while the	3/2-way directional seated valve acc. to D 7300 acc. to D 7470 A/1 1)		Nom. voltage U_N
		Standard, with plug (For other versions, see the corresponding pamphlets)		
HRP 4(V) HRP 5(V)	solenoid valve is energized	G 3-0 B 0,4 - G 24	WH 1H B 0,4 - G 24	24V DC
		WG 3-0 B 0,4 - WG 230	WH 1H B 0,4 - WG 230	230V AC 50/60 Hz
HRP 7V	solenoid valve is energized	G 3-1 B 0,6 - G 24	---	24V DC
		WG 3-1 B 0,6 - WG 230	---	230V AC 50/60 Hz
HRP 4(V) HRP 5(V)	solenoid valve is de-energized	GZ 3-0 B 0,4 - G 24	WH 1M B 0,4 - G 24	24V DC
		WGZ 3-0 B 0,4 - WG 230	WH 1M B 0,4 - WG 230	230V AC 50/60 Hz
HRP 7V	solenoid valve is de-energized	GZ 3-1 B 0,6 - G 24	---	24V DC
		WGZ 3-1 B 0,6 - WG 230	---	230V AC 50/60 Hz
HRP 7V - X	---	Blanking plate; Port X blocked with a tapped plug		

Table 1: Basic type, size

	Provision for optional mounting of a directional seated valve (table 2)					
Standard version	HRP 1	HRP 2	HRP 3	HRP 4	HRP 5	---
With pre-relief	---	---	HRP 3V	HRP 4V	HRP 5V	HRP 7V(-X)
Nom. size approx.	For dimensional drawings, see sect. 4 ++					
Flow Q_{max} approx. (lpm)	20	35	50	80	140	400
Pressure p_{max} (bar) at port	A, B, Z	700	700	500	500 3)	500
	L	depressurized to the tank				
Control oil volume (cm ³)	0.2	0.4	0.5	1.3	2.5	13.8
Mass (weight) approx. (kg)	0.3	0.4	0.7	1.2 2)	1.9 2)	7.9 2)

1) Type WN 1H B 0,4.. or WN 1M B 0,4.. may be used also for operating pressure below 320 bar

2) With directional seated valve:
 G 3-0 B 0,4-.. = 0.4 kg
 WG 3-0 B 0,4-.. = 0.4 kg
 G 3-1 B 0,6-.. = 0.7 kg
 WG 3-1 B 0,6-.. = 0.7 kg
 WH 1H B 0,4-.. = 0.6 kg
 WH 1M B 0,4-.. = 0.6 kg

3) $p_{max} = 450$ bar with directly mounted valve type WH 1

Table 4: Flow pattern symbols

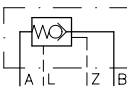
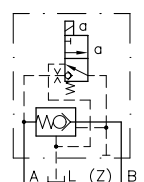
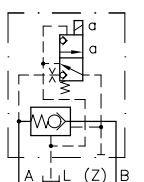
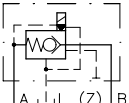
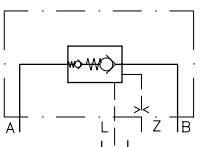
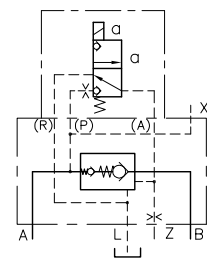
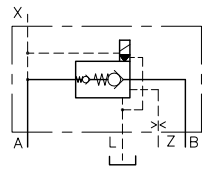
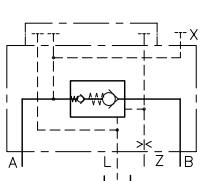
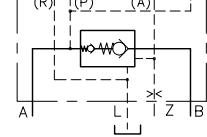
Basic type	Version with directly mounted 3/2-way directional seated valve		
HRP 1, HRP 2 HRP 3(V) HRP 4(V) HRP 5(V) 	HRP 4(5) (V) - G(WG) 3-0 B 0,4 -.. 	HRP .. - WH 1H B 0,4 -.. 	Simplified illustration (for circuit diagrams) 
HRP 7V 	HRP 7V - G(WG) 3-1 B 0,6 -.. 	Simplified illustration (for circuit diagrams) 	
HRP 7V - X 	- GZ 3-1 - WGZ 3-1 		

3. Additional parameters

3.1 General and hydraulic

Design Spring loaded ball seated valve, zero leakage
 Pipe connection Via customer furnished manifold
 Ports A, B = Consumer (main passage)
 Z = Control port
 L = Leakage port (piston cavity relief)
 Hydraulic fluid Hydraulic oil acc. to DIN 51524 table 1 to 3; ISO VG 10 to 68 acc. to DIN 51519
 Viscosity range: min. approx. 4; max. approx. 1500 mm²/sec
 Optimal operation range: approx. 10 ... 500 mm²/sec
 Also suitable are biologically degradable pressure fluids type HEPG (Polyalkylenglykol) and HEES (synth. ester) at operation temperatures up to approx. +70°C.
 Temperature Ambient: approx. -40 ... +80°C
 Fluid: -25 ... +80°C, pay attention to the viscosity range!
 Start temperature down to -40°C are allowable (Pay attention to the viscosity range during start!), as long as the operation temperature during subsequent running is at least 20K higher. Biological degradable pressure fluids: Pay attention to manufacturer's information. With regard to the compatibility with sealing materials do not exceed +70°C.
Attention: Observe the corresponding notes in pamphlets D 7300 or D 7470 A/1, when a directional seated valve is mounted and the operating temperature exceeds 35°C!

Δp-Q-curves

Control pressure
 p_{contr} (bar) at port Z
 and $p_B = 0$ bar
 (pressure at port B)

For release

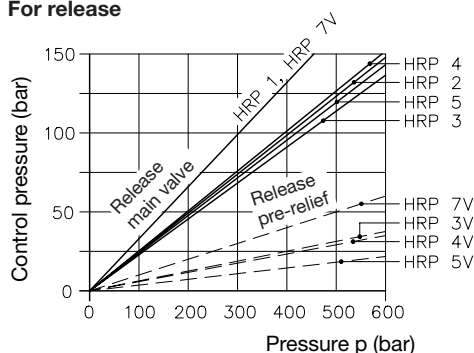

For maintaining the valve open

$$p_{contr} = a \Delta p + b p_B + c$$

standing for
 Δp = Back pressure (bar)
 A → B acc. to the
 Δp -Q-curve (below)
 p_B = Pressure (bar) at port B

	HRP 1	HRP 2	HRP 3(V)	HRP 4(V)	HRP 5(V)	HRP 7V
a	0.235	0.22	0.21	0.235	0.22	0.32
b	0.03	0.03	0.11	0.07	0.05	0.04
c	4.8	3.7	3.7	3.0	3.7	3.2

Hydraulically released

— B → A
 - - - A → B

Oil viscosity during
 the measurement
 60 mm²/s

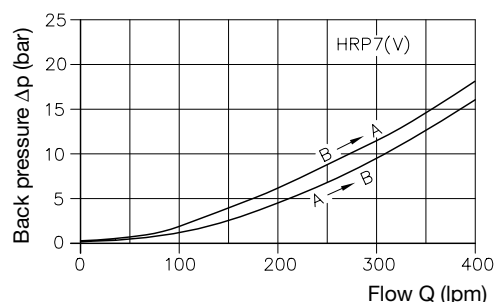
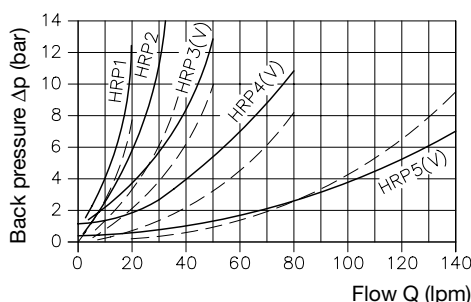

3.2 Orifice inserts at control port Z

Orifice inserts are used to prevent decompression surges (see also sect. 1). It should be kept in mind that a too pronounced damping might cause a prolonged closing time. The optimum orifice diameter can be only found by tests.

Order example: HRP 2 - B 0,4

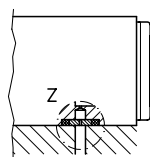

Orifice insert
 The manifold is not available at HAWE!

HRP 1 ... 5

Order No. of orifice insert	∅ (mm)	Coding
B 5585 038/1	0.4	B 0,4
B 5585 037/1	0.6	B 0,6
B 5585 034/1	0.8	B 0,8

HRP 7

Type of orifice insert	∅ (mm)	Coding
EB 1-0,4	0.4	B 0,4
EB 1-0,6	0.6	B 0,6
EB 1-0,8	0.8	B 0,8

4. Unit dimensions

All dimensions in mm, subject to change without notice!

4.1 Basic version

Type HRP 1, HRP 2
HRP 3(V), HRP 4(V), HRP 5(V)

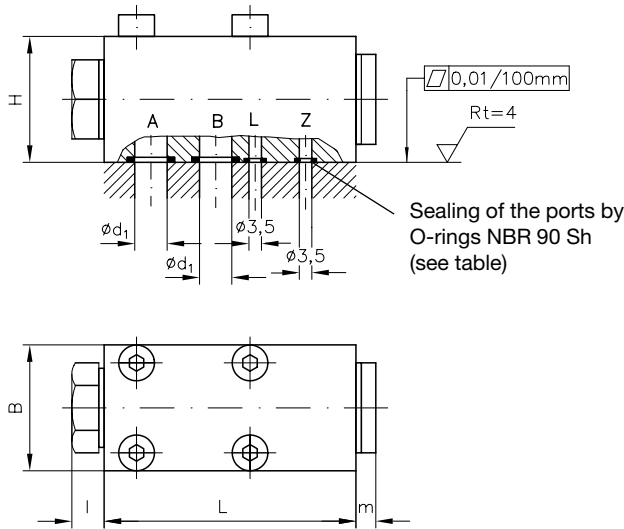

Hole pattern of the manifold (top view)

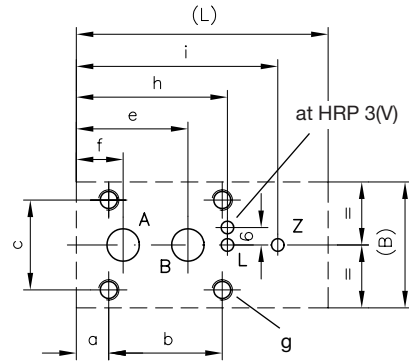

Type	L	B	H	a	b	c	f	e	h	i	l	m	d ₁	g	Max. torque (Nm)	Sealing by O-rings A and B	L and Z
HRP 1	62	25	20	5.5	26	18	10	21	36	50	9	3.5	5	M4, 5 deep	2.6	6.07x1.78	4.47x1.78
HRP 2	65	30	25	7	24	22	12.5	26	38.5	52	9	4	6.5	M5, 5 deep	5	7.65x1.78	
HRP 3(V)	70	35	35	9	26	25	13	31	42	56	9	4	9	M6, 10 deep	9	9.2x2.62	
HRP 4(V)	88	50	35	7	48	38	17	37	53	71	10.5	5	11	M8, 10 deep	22	12.37x2.62	
HRP 5(V)	102	60	40	10	48	42	21	44	62	85	13.5	5	14	M8, 10 deep	22	15.55x2.62	

Type HRP 7V
HRP 7V-X

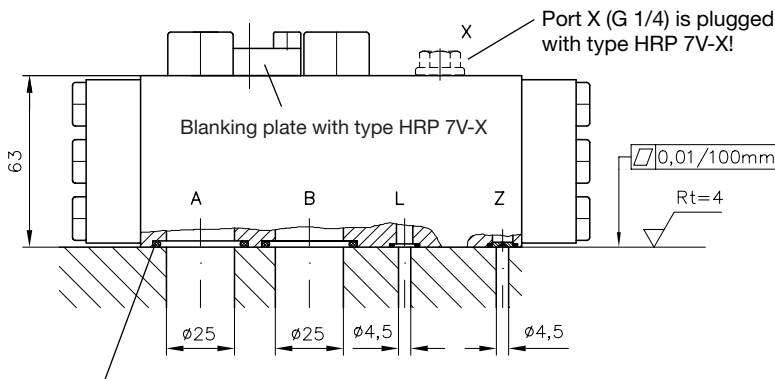

Sealing of the ports by O-rings:
A and B = O-ring 29.2x3 NBR 90 Sh
L and Z = O-ring 8x1.5 NBR 90 Sh

Hole pattern of the manifold (top view)

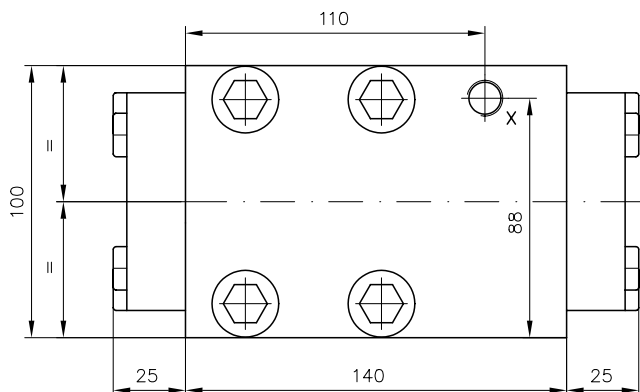
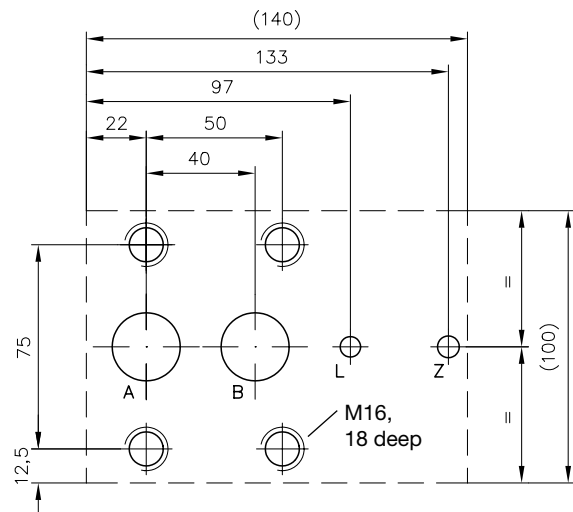

4.2 Version with 3/2-way directional seated valve

Type HRP 4(V) - G(WG)...-0 B 0,4 - G(WG) ...
 HRP 5(V) - G(WG)...-0 B 0,4 - G(WG) ...

For missing dimensions of the directional seated valve (size 0), see D 7300 !

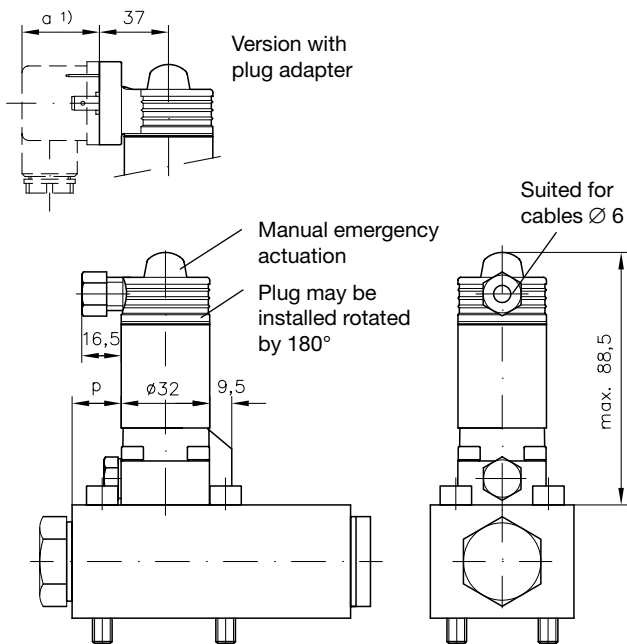

Type	p
HRP 4(V)-G(WG)..	14.5
HRP 5(V)-G(WG)..	17

Type HRP 4(V) - WH 1H(M) - G(WG)...
 HRP 5(V) - WH 1H(M) - G(WG)...

For missing dimensions of the directional seated valve type WH 1 see D 7470 A/1!

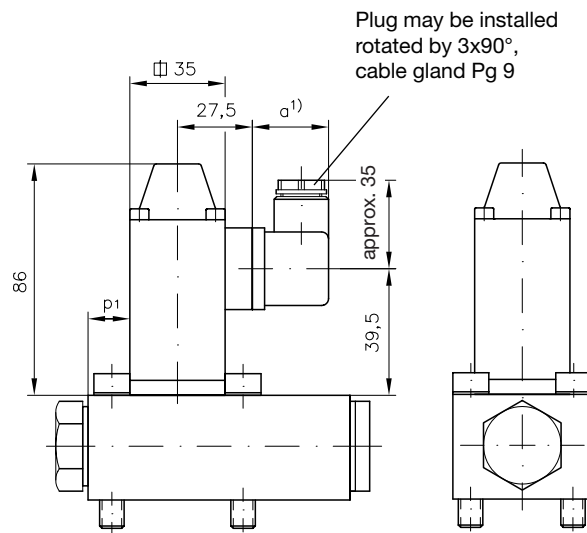

Type	p1
HRP 4(V)-WH 1..	13.5
HRP 5(V)-WH 1..	17

Type HRP 7V - G(Z) 3-1 B 0,6 - G ...
 HRP 7V - WG(Z) 3-1 B 0,6 - WG ...

For missing dimensions of the directional seated valve (size 1), see D 7300 !

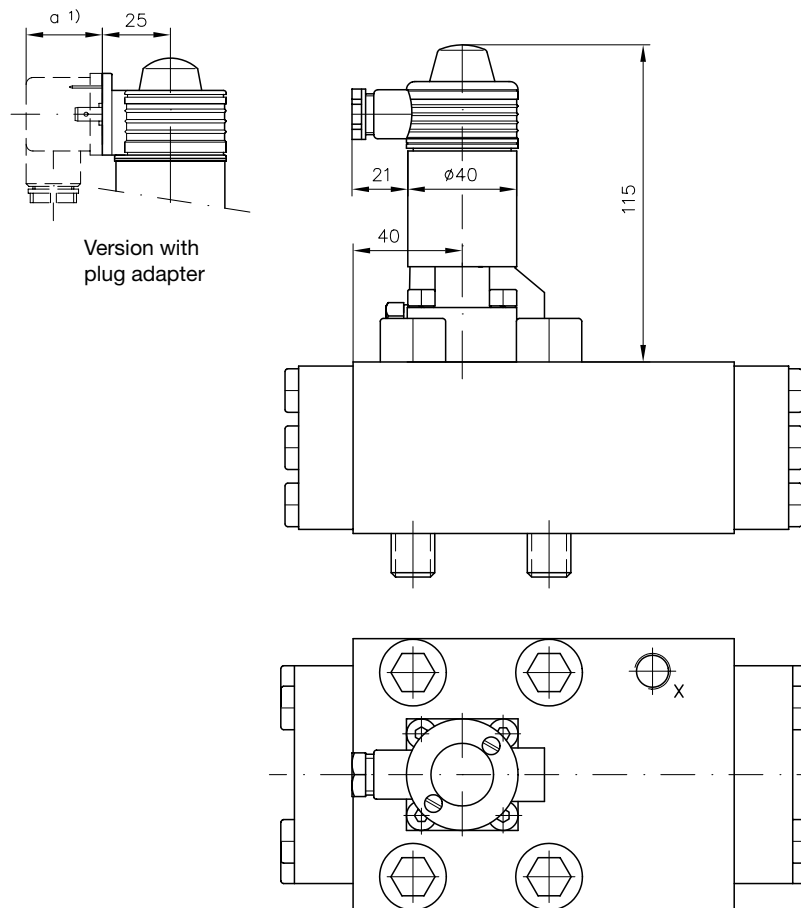

1) This dimension depends on the manufacturer and may be max. 40 mm (conf. DIN 43650)

Coding	a
G..	29
WG..	34
L..	40