

Design Features include:

- The high torque ratings and large bore capacities result in savings of up to 35% compared to the competition
- Long Term Grease (LTG) lubrication and a four-point seal provide maximum lubrication retention, extend the coupling life and contribute to reduced maintenance needs.
- 3 year heavy duty warranty when used with LTG
- Lifelign's triple-crowned teeth are crowned on the root, tip and face to articulate freely, minimizing wear caused by misalignment. The triple-crowned teeth protects equipment from damaging loads by eliminating tip-loading while reducing backlash and radial clearances.

Applications:

- Pumps
- Paper machines
- Conveyors
- Pulpers
- Crushers

Industry Compliant:

- ATEX II 2GD c T5

Special design options:

- Brakes adapters
- Axial slide couplings
- Floating shaft assemblies
- Electrically insulated

Rexnord Falk Lifelign Gear Coupling

Customer-focused solutions. Reliable Performance. Trusted Brands.

You want a trusted name when it comes to providing engineered power transmission products that improve productivity and efficiency. Rexnord® provides superior products for your industrial applications world wide. We work closely with you to reduce maintenance costs, eliminate redundant inventories and prevent equipment downtime.

Falk Lifelign Gear Couplings

Large bore capacity gear coupling with superior torque ratings. Available in both single and double engagement designs.

Falk is a Rexnord brand.

Reduced head capscrews and non-turning locknut allow one-wrench tightening

Triple-crowned AGMA 20° tooth design with crowning at the root, tip and face of each tooth

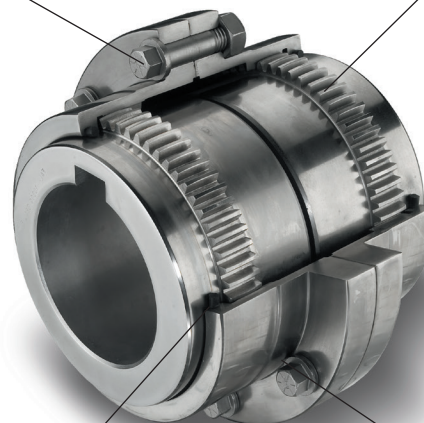

Viton® seals provide long life in high temperature applications and four-point seal improves lubrication retention during misalignment conditions

Lubrication plug locations are ideal for effective application of grease



ATEX II 2GD c T5



Torque Demands Driven Machine	Typical Application for Electric Motor or Turbine Driven Equipment	Typical Service Factor
	Constant torque such as centrifugal pumps, blowers and compressors	1.0
	Continuous duty with some torque variations including plastic extruders and forced draft fans	1.5
	Light shock loads from metal extruders, cooling towers and log haulers	2.0
	Moderate shock loading as expected from a car dumper, stone crusher, vibrating screen	2.5
	Heavy shock load with some negative torques from reciprocating pumps, compressors, reversing turnout tables	3.0
	Frequent torque reversals such as reciprocating compressors with frequent torque reversals which do not necessarily include reverse rotations	Consult Rexnord Engineering

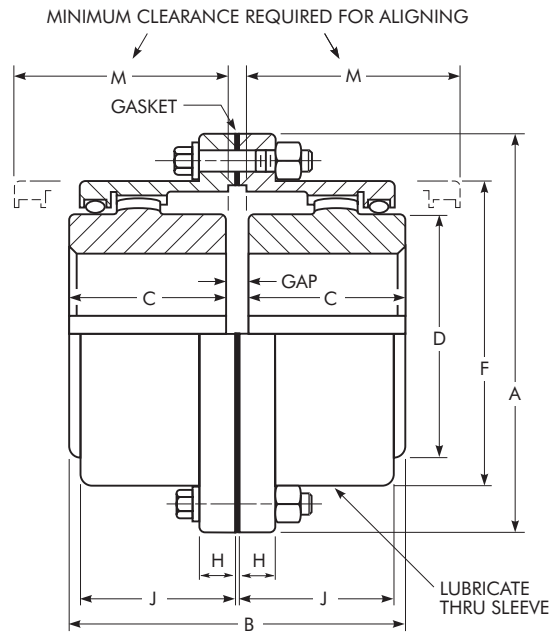

Coupling Size	Torque Rating Nm	Max Allowed Speed rpm	Min Bore mm	Max Bore mm	Gap mm	A mm	B Std Hub mm	B Long Hub mm	C Std Hub mm	C Long Hub mm	D mm	F mm	H mm	J mm	M mm	Lube Weight kg	Coupling Weight* with no bore kg
1010G	1 140	8 000	13	50	3	115	88	206,2	42	101,6	68	83	14	39	51	0,04	4,5
1015G	2 350	6 500	20	65	3	152	101	231,6	49	114,3	86	105	19	48	61	0,07	9,0
1020G	4 270	5 600	26	78	3	177	127	263,0	62	130,0	105	126	19	59	77	0,11	15,9
1025G	7 470	5 000	32	98	5	212	158	303,8	77	149,4	130	154	21	72	92	0,21	29,5
1030G	12 100	4 400	39	111	5	239	187	335,2	91	165,1	152	180	21	84	107	0,36	43,1
1035G	18 500	3 900	51	134	6	279	218	374,4	106	184,2	177	211	28	98	130	0,54	68,0
1040G	30 600	3 600	64	160	6	317	247	412,4	120	203,2	209	245	28	111	145	0,90	97,5
1045G	42 000	3 200	77	183	8	346	277	496,6	134	244,3	235	274	28	123	166	1,00	136
1050G	56 600	2 900	89	200	8	388	314	598,2	153	295,1	254	305	38	141	183	1,70	191
1055G	74 000	2 650	102	220	8	425	344	604,8	168	298,4	279	334	38	158	204	2,20	249
1060G	90 400	2 450	115	244	8	457	384	617,6	188	304,8	304	366	25	169	229	3,10	306
1070G	135 000	2 150	127	289	10	527	451	629,8	220	309,9	355	424	28	196	267	4,20	485