

Acceleration Sensor with constant current power

AS - 062

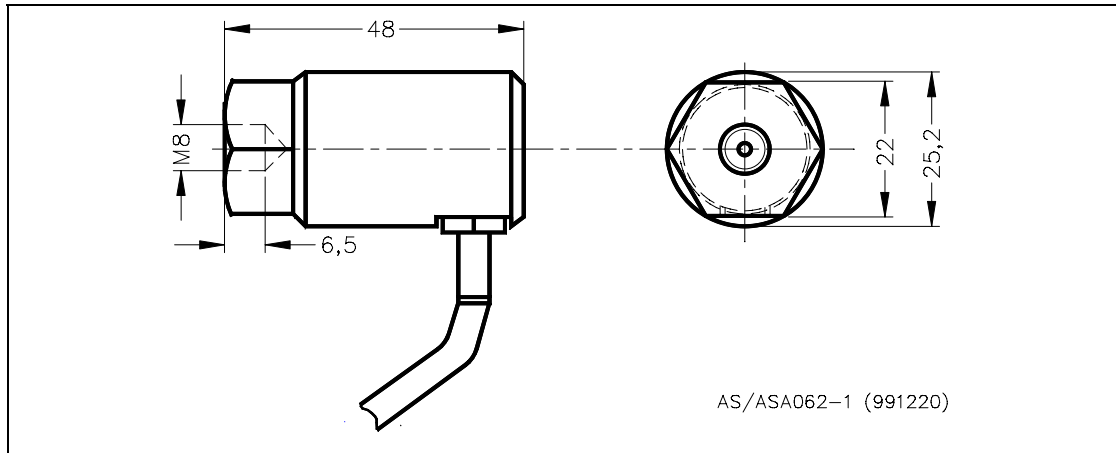

Fig. 1 Dimensions

1 Application

The AS-062 is mainly used for measurement of vibration acceleration at rotating machines such as turbines, pumps, compressors, etc.

2 Measurement principle

The acceleration sensor operates according to the piezo-electric compression principle. A piezo-ceramic disc and an internal sensor mass form a spring-mass system in the sensor.

If this system is subjected to vibrations the mass produces an alternating force on the ceramic disc. As a result of the piezo effect this produces an electrical charge that is proportional to vibration acceleration.

An integrated amplifier converts this charge signal into a usable voltage signal.

2.1 Polarity

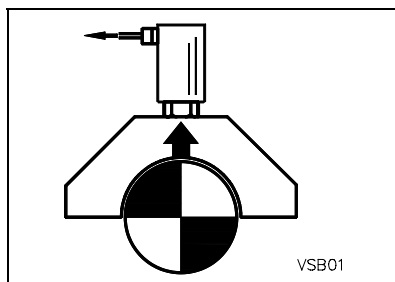

A movement of the bearing housing in the direction shown below produces a positive signal.

3 Technical Data

| | | |
|---|--------------------------|-------|
| Transmission factor (referred to the measured value at 80 Hz and 25 °C) | 100 mV/g | ± 5 % |
| | 10,2 mV/m/s ² | ± 5 % |

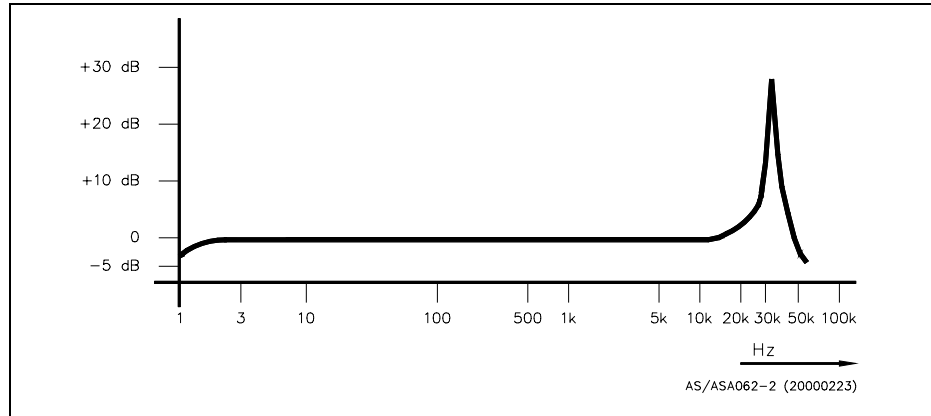

Fig. 2 Typical frequency response curve of the transmission factor

| | |
|--|---|
| Overload capacity | continuous 500 g shock 5000 g (any direction) |
| Operating temperature range | -50 °C ... + 125 °C |
| Storage temperature range | -50 °C ... + 125 °C |
| Measuring range | ± 80 g ($U_{\max} = + 24 \text{ V} \dots + 30 \text{ V}$) ± 40 g ($U_{\max} = + 20 \text{ V}$) ± 20 g ($U_{\max} = + 18 \text{ V}$) |
| Transverse sensitivity (80 Hz) | ≤ 8 ... 10 % |
| Operating frequency range | 4 Hz ... 10 kHz ± 5 % 1,5 Hz ... 13 kHz (± 3 dB) |
| Resonance frequency | > 20 kHz |
| Constant-current supply I_B | 4 mA (2 mA ... max. 10 mA) polarised |
| Power U_{\max} | + 24 V (+ 18 V...+ 30 V) DC polarised |
| Dynamic internal resistance of output | ≤ 300 Ω (Operating frequency range) approx. 2 kΩ (Resonance frequency) (Level control 1 V_{eff} $I_B = 4 \text{ mA}$) |
| Passive potential (-50 °C ... + 100 °C) | + 12,5 V ± 1,5 V |
| Sensitivity response to temperature | ≤ 5 % of meas. value (ref. at 25 °C) |
| Distortion sensitivity | < 0,002 g/(μm/m) |
| Magnetic field sensitivity | < 80 Hz: 0,001 g/mT < 1 kHz: 0,014 g/mT |

| | |
|--|---|
| Insulation resistance (Housing to power 0 V) | ≥ 20 MΩ |
| Interference voltage suppression between housing and 0 V (frequency-dependent) | < 0,5 kHz ≥ 100 dB < 1 kHz ≥ 95 dB 10 kHz ≥ 75 dB |
| Protection class acc. to DIN 40 050 | IP 67 |
| Mass | approx. 130 g (without cable) |
| Housing material | Stainless steel 1.4301 |

EMC

| | |
|-------------------------|--------------------------------|
| Interference resistance | acc. to DIN EN 50082-2 / 96-02 |
| Interference emission | acc. to DIN EN 55011 / 98-12 |

Connecting cable

| | |
|------------------------------|---|
| Length (typical) | 5 m, 10 m, 20 m (optional protecting tubing for 5 m, 10 m) |
| Construction | 2-conductor stranded + shield |
| Outer material insulation | ETFE |
| Outer insulation colour | black |
| Outside diameter | 3,3 mm (± 0,15 mm) |
| No. of conductors | 2 |
| Conductor cross-section area | 0,14 mm ² (7 x 0,16 mm) |
| Conductor insulation | ETFE |

Conductor layout

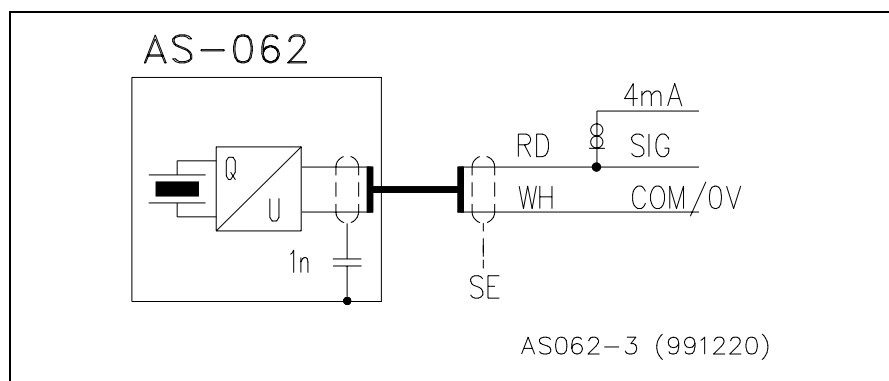

Fig. 3 wiring diagram

4 Mounting

4.1 Coupling

General rule.

The weight of the acceleration sensor should always be lower at least by a factor ten than the weight of the object onto which it is mounted.

The acceleration sensor is an additional parasitic mass which loads the object on which it is mounted and this changes the vibration behaviour if it is too large.

4.2 Mounting the acceleration sensor

The acceleration sensor requires a friction-locked, contact resonance-free, rigid mounting to the object, particularly for measurements at high frequencies.

- ◆ The sensor is to be attached using the supplied threaded stud, either:
- ◆ Threaded stud M8 x 14 or
- ◆ Threaded stud M8 / 1/4" 28 UNF.

The sensor may be mounted in any direction.

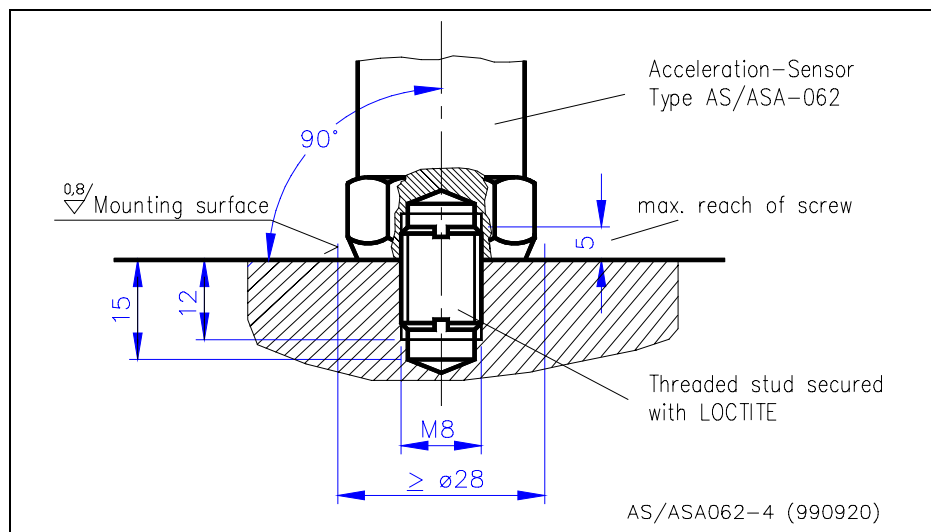
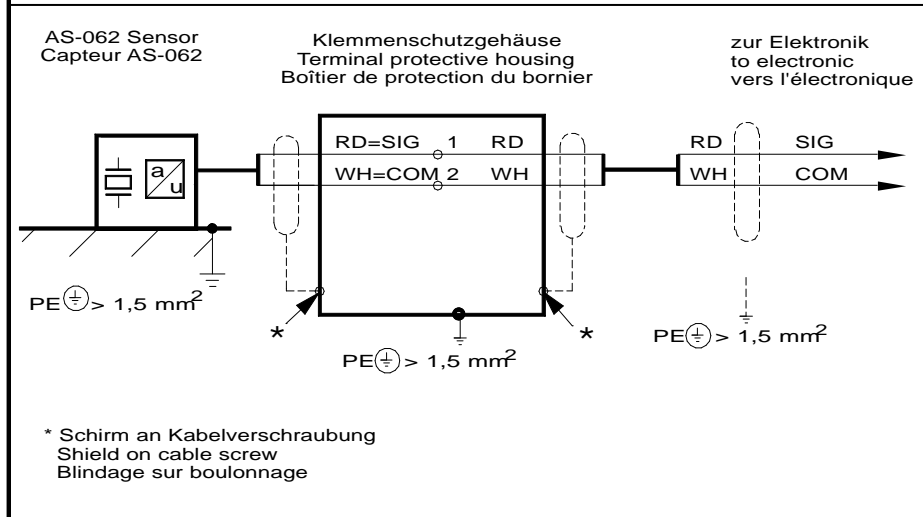
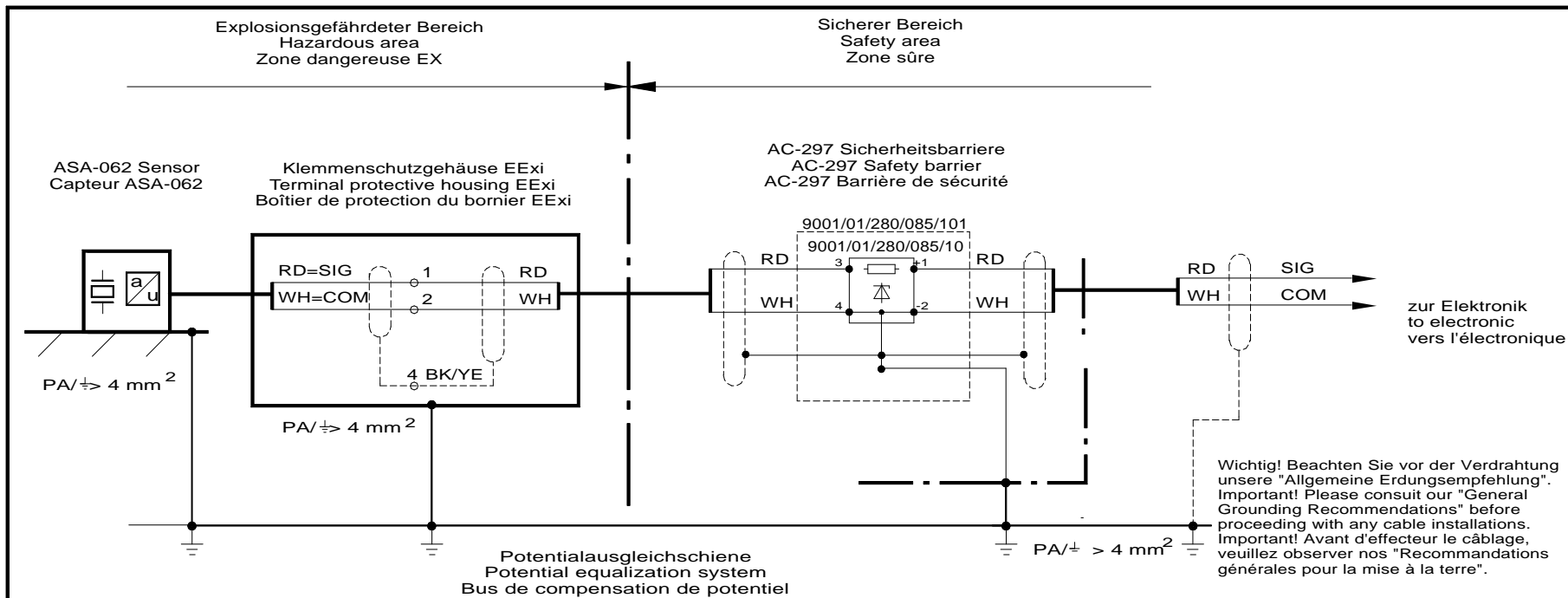

Fig. 4 Mounting

- ◆ The mounting surface in the area of the sensor must be flat and machined
- ◆ Provide a size M8, resp. 1/4" threaded hole 12 mm deep in the surface of the machine
- ◆ Apply a thin film of silicone grease on the mounting surface to prevent contact resonance
- ◆ Screw the M8, resp. 1/4", stud into the mounting surface in accordance with Fig. 4 and secure it with adhesive, e.g. LOCTITE 243 medium strength, or LOCTITE 270 high strength
- ◆ Maintain a max. length of the threaded stud ≤ 5 mm for acceleration sensors
- ◆ Screw the sensor onto the threaded stud, observing the corresponding maximum torque for the threaded stud
- ◆ Recommended maximum torque for the supplied threaded stud is 3,5 Nm



Adernfarbe / Core colour / Couleur des brins
 RD = rot / red / rouge
 WH = weiß / white / blanc
 BK = schwarz / black / noir
 BN = braun / brown / brun
 BU = blau / blue / bleu
 YE = gelb / yellow / jaune
 YE/BK = gelb/schwarz / yellow/black / jaune/noir
 GN/YE = grün/gelb / green/yellow / vert/jaune

| | Datum | Name |
|----------|----------|----------|
| Bearb. | 04.09.02 | Schumann |
| Gepr. | 04.09.02 | Hölzel |
| Änderung | 07.02.03 | Giegeler |

Beschleunigungs-Sensoren Typ AS-062 / ASA-062
 Acceleration sensors type AS-062 / ASA-062
 Accéléromètres type AS-062 / ASA-062

 Brüel & Kjær Vibro
 Leydheckerstr. 10, 64293 Darmstadt

Zeichng. Nr.
C006 909