

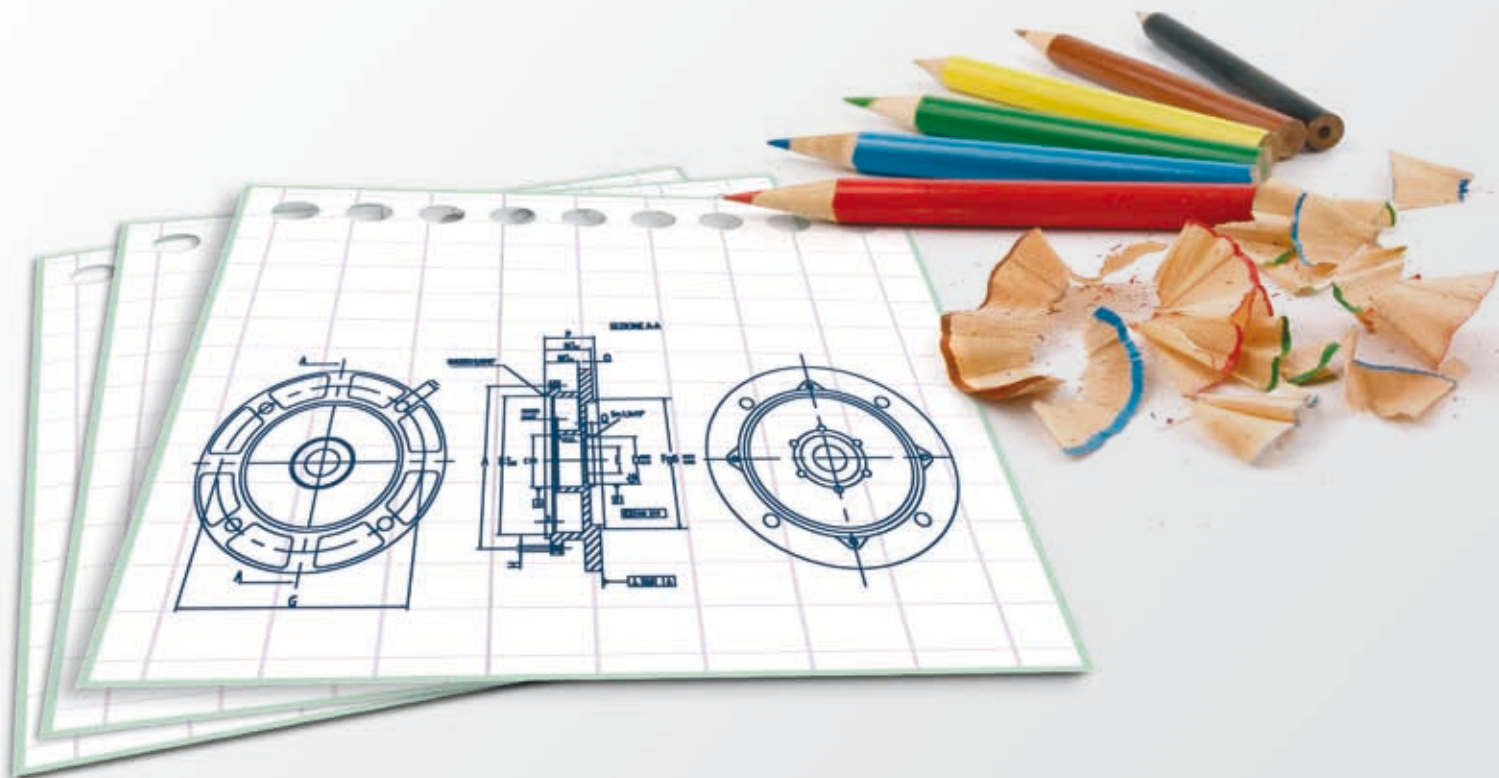

**NERIMOTORI**  
*moving together.*



**Quality, for us, is a common feature also to the Basic range.**



## THREE-PHASE INDUCTION MOTORS

Simple as a child's drawing, perfect as all our creations: the motors of the Basic Line are economic, reliable and guaranteed. Our second line motors are also first quality products.

Three phase motors for many different industrial applications: food, ceramics, car wash, fans and crains, textile, packing and wood working machines.



Zone 2/22  
G/D upon request

Upon request

**NERI MOTORI s.r.l.**

Via A. Fleming, 6/8  
40017 San Giovanni in Persiceto - Bologna - ITALY  
Tel. +39 051 6870911 - Fax +39 051 825858  
[www.nerimotori.com](http://www.nerimotori.com)  
e-mail: [info@nerimotori.com](mailto:info@nerimotori.com)



**NERIMOTORI**  
*moving together.*

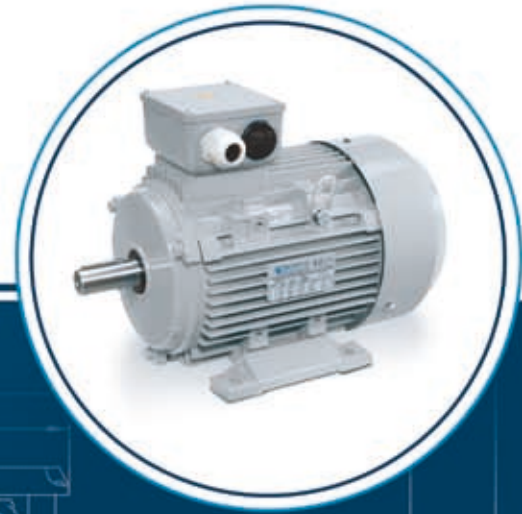

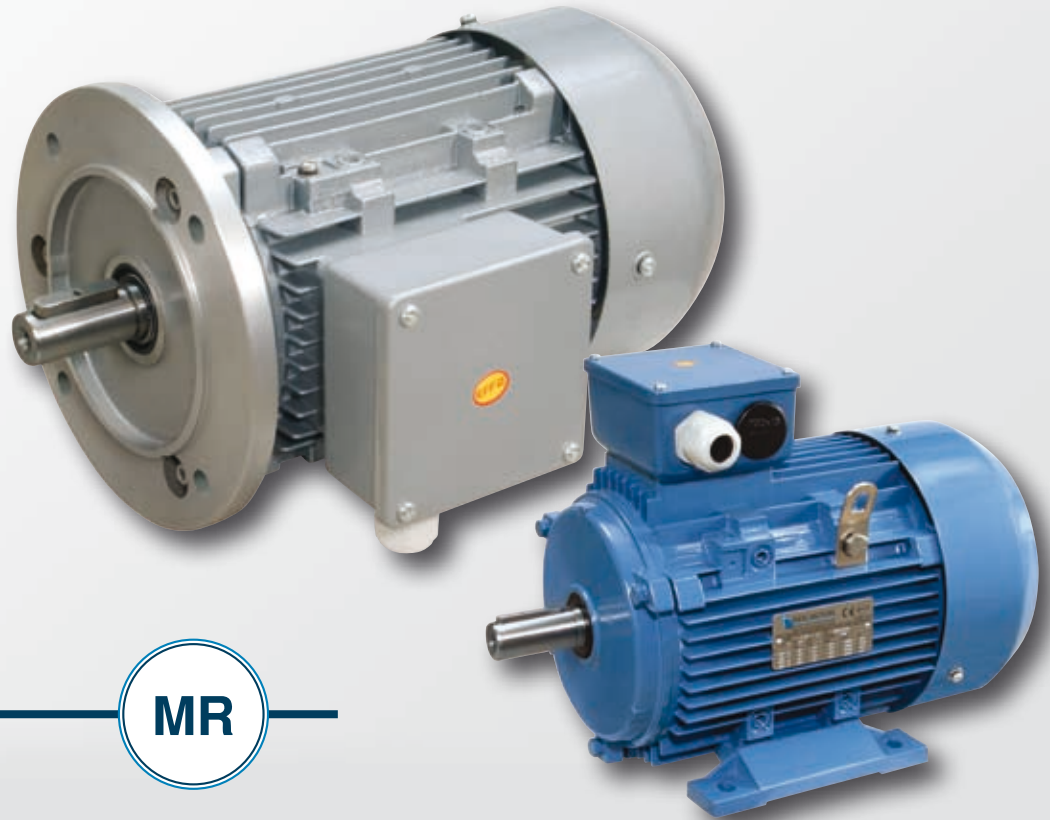

**MR**

Magnetic core **1**

Dynamic balanced rotor **2**

Bearings guarantee - ZZ - C3 / Locked over size 112  
With greaser from size 160 **3**

For vertical mounting. Upon request special bearings from 160 size **4**

Large voltage range:  
230/400/50 Hz - 280/480/60 Hz (up to 132 size) **5**  
400/690/50 Hz - 480/830/60 Hz (from 160 size)  
Other version upon request

Versions: B3 - B5 - B14 **6**

2 oil seal (standard) **7**



Upon request

Three-phase induction motors MR type

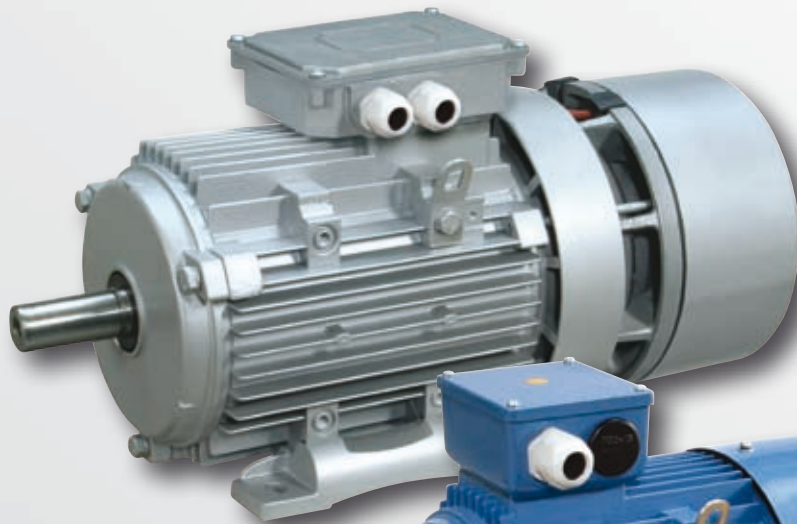

MH

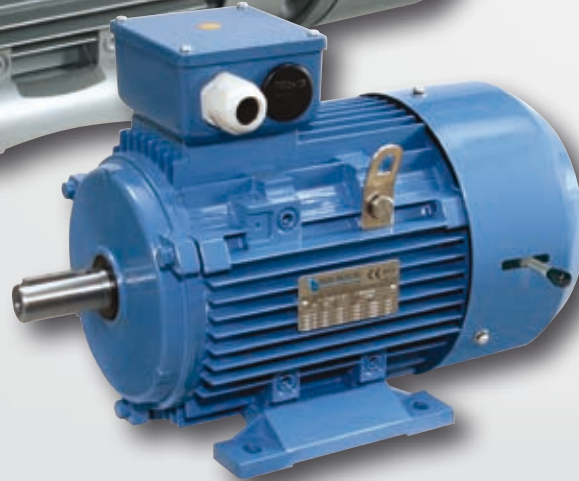

MK

- 8** IP 55. Other protections available upon request
- 9** S1/Class F. Other insulations available upon request
- 10** Inverter duty (standard)
- 11** Above size 90 flange and shield with steel ring
- 12** 3 PTC standard from size 160, upon request on other size
- 13** IEC 34-1 (standard)  
CEI/IEC 72-1 (standard)
- 14** Removable feet from size 56 to 132 included
- 15** Alluminium body from size 56 ÷ 132  
Cast iron body from size 160 ÷ 355

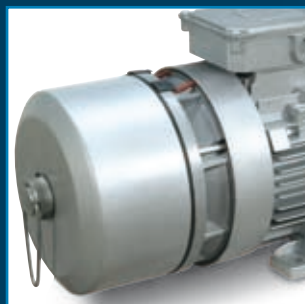

Three-phase induction self brake motors MK and MH types

## The Certification of the company quality system conforms to ISO 9001 Standards (2000)

In line with company quality policy, NERI MOTORI is Certified conforming to ISO 9001 Standards (2000). The effort made in achieving this goal has resulted in constant improvements in product and Customer service. The management's willingness to keep the Company at worldwide competitive levels has triggered a worthy process of improvement, in all the Company's activities, with constant CUSTOMER SATISFACTION monitoring. This has been achieved thanks to investments made in the training of personnel, in the design and in the investments of machines and state-of-the-art technologies for tests at the initial stages, during production and during the final stage.



## Marking

EUROPEAN STANDARD

Per the provisions of the Machine Directive 89/392/EEC, the electric motor is a component that may not cause hazards to people, animals or property.

The following directives are applied to this end:

- 1) Low Voltage 2006/95/CE, according to which the electric motor is "low-voltage electrical material";
- 2) Electromagnetic Compatibility 89/336/EEC.

In compliance with these directives, type tests were carried out on Neri standard production; in particular, European Standard EN-60204-1 was applied for safety purposes.

The European Standard EN-55014 (1994) was applied for EMC, carrying out:

- a) Guided peak tests in the 150 KHz - 30 MHz frequency range,
- b) Radiated tests in the 30 MHz-1 GHz frequency range.

All of the production passed the tests or was modified to do so.

The corresponding documentation is available from our headquarters and may be supplied upon request.

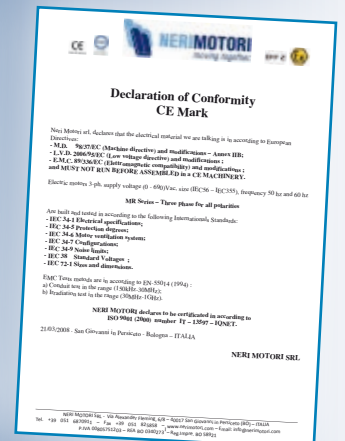
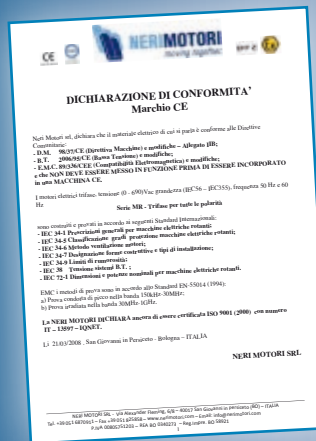

## ATEX Motors - 94/9/CE

Neri Motori designs, produces, and self-certifies ATEX Motors for zone 2 zone 22.

Programmed third party body certification.

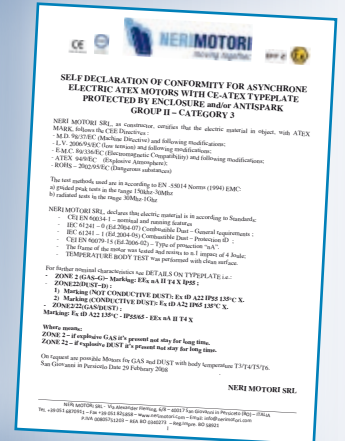
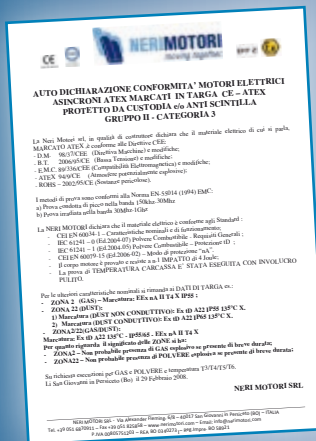

## Standard production reference standards

Standards	IEC (World)	CENELEC (Europe)	CEI (Italy)	UNEL (Italy)	DIN (Germany)	VDE (Germany)	BS (U.K.)	NFC (France)
Electrical specifications	IEC 34-1	HD 53.1.S2	CEI EN 60034-1			VDE 0530T1	BS 2613 5000	NFC 51-100 51-120
Protection class	IEC 34-5	EN 60034-5	CEI EN 60034-5	UNEL 05515	DIN 40050	VDE 0530	BS 4999-20	NFC 51-115
Motor ventilation system	IEC 34-6	EN 60034-6			DIN IEC 34-6		BS 4999-21	
Configurations	IEC 34-7	HD 53.7	CEI EN 60034-7	UNEL 05513	DIN 42950			NFC 51-117
Noise limits	IEC 34-9		CEI EN 60034-9					
Standardized voltages	IEC 38		CEI 8-6					NFC 6
Sizes and dimensions	IEC 72-1		CEI IEC 72-1	UNEL 13113 13117 13118	DIN 42673 42677 42946		BS 3979	NFC 51-105 51-120
Machinery safety electric equipment of the machines			CEI EN 60204-1					

## The Certification of the company quality system conforms

<b>ISO 9001 (2000)</b>	Model for quality assurance in design, project, construction, trading, assistance of electric motors
<b>UNI EN 30012</b>	Metrological confirmation system for measuring equipment



<b>89/392 CE*</b>	Machines directives - MD
<b>73/23 CE</b>	Low voltage directive - LVD
<b>89/336 CEE</b>	Electromagnetic compatibility directive - EMC
<b>ROHS - 2002/95/CE</b>	Dangerous Substances Directive

\* upon request

### USAGE

- Unless otherwise specified, this manual uses I.S. International System units of measure (meter, kilogram, second, ampere).
- Lengths are in mm. in all size tables.
- The terminal covers in the overall dimensions drawings are the double ones (IP65)

## Technical specifications

The electric motors covered by this catalogue are constructed and tested in accordance with the IEC Norms which implement the most important EEC European Directives in the electrical engineering sector.

All the induction motors we produce have die-cast squirrel cage motor and wound stator, are enclosed and have external cooling to IEC 34-6 (IC 411).

**The power supply voltages** of the standard motors in the catalogue comply with IEC 38 (1983) and CEI-8-6 (March 1990): 230V/400V/50Hz for the three-phase models with permissible variation of  $\pm 10\%$  of the rated voltage.

All electrical and mechanical specifications, as well as the testing methods, comply with IEC 34-1 and CEI EN 60034-1.

**The output powers** and machine sizes comply with CEI IEC 72-1, while construction forms B3, B5 and B14 are to IEC 34-7.

All geometrical dimensions are standardized in accordance with the UNEL tables 13113-71, 13117-71, 13118-71/CEI IEC 72-1.

**The degrees of protection** of the casings comply with CEI EN 60034-5. Our standard motors have IP 55 protection and are insulated overall in class F to IEC 34-1 and CEI EN 60034-1.

As standard, **the drive shafts** and tangs have dimensions and tolerances to CEI IEC 72-1.

Standard shafts are constructed in C43/C40 steel.

We use preloaded **bearing** rings of the best makes, which our company considers reliable.

**Motors** are manufactured for standard S1 service, other executions on request.

## Mechanical specifications

### Wound Stators

High-quality magnetic sheet metals are used for most of the production, to ensure constant high performance.

The copper used is impregnated with a double layer of insulating enamel to ensure high resistance to electrical, thermal and mechanical stress.

The standard insulation class of the motor is F, may be supplied upon agreement with the manufacturer.

The ambient temperature considered is 40 °C.

Tropicalization processes are available through impregnation with paints having high hygroscopic qualities, for use in areas with high ambient humidity >60% R.H.

### Rotors (tropicalized)

These are die-cast aluminium squirrel-cage rotors.

### Keys

These are made of C40 steel with dimensions standardized per CEI IEC 72-1. The thread diameters of standard shafts, in compliance with standard DIN 332. Body according CEI-IEC 72-1.

### Frame (per CEI-IEC 72-1)

Die-cast aluminium with high mechanical capacity, good thermal conductivity, and very lightweight.

Frames are available in a version with standard tie-rods, with studs upon request.

### Motor terminal board

For the B3 frame with feet, the terminal board is placed on top in standard production, or may be placed on the right or left side upon request.

### Flanges and shields (per CEI-IEC 72-1)

Standard dimensions per CEI-IEC 72-1.

From size 56 to 132 are in aluminium, while from size 160 to 355 cast iron.

### Cooling (per IEC 34-6 and EN 60034-6)

Obtained by means of a two-way rotary fan with radial blades keyed onto the motor shaft IC 411.

Made of plastic, it has a high operating temperature of 100°C.

For applications with electronic controls such as inverters, assisted power cooling is available via an auxiliary cooling-type motor IC416, also in kit form.

### Fan cover

Realized in painted sheet.

### Noise level (CEI EN 60034-9)

Sound pressure and power levels were measured on single- and three-phase motors, one meter away from the machine, and weighted according to curve A (ISO R 1680). At 50 Hz for relative values at 60 Hz, this increases by an average of 4 dbA.

### Mechanical tolerances (per CEI-IEC 72-1)

Table shows the mechanical tolerances where the motor is keyed with the load.

Description	Dimension	Tolerance
Shaft diameter	D	$\leq \varnothing 28 \text{ mm}$ j6
		$\varnothing 32 \text{ mm} \div \varnothing 48 \text{ mm}$ k6
		$\varnothing 55 \text{ mm} \div \varnothing 110 \text{ mm}$ m6
CEI IEC 72-1 Standardized keys	F	h9
		G
	G	2 mm $\div$ 6 mm h9
7 mm $\div$ 16 mm h11		
CEI IEC 72-1 Standardized flanges	N	$\leq \varnothing 450 \text{ mm}$ j6
Axis height per CEI IEC 72-1	H	+0 $\div$ -0.5 mm
Shaft stop	E	+0 $\div$ -0.2 mm



# Technical and mechanical specifications

## Available configurations (to specify when ordering)

The table shows the available motor configurations and installation positions per IEC 34-7. Versions B3, B5, B14.

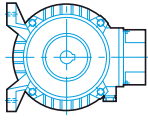
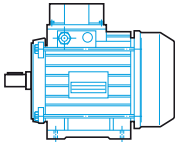
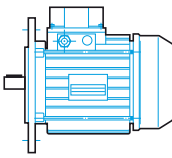
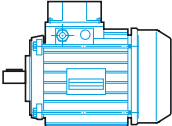
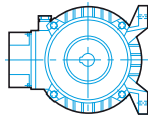
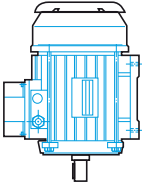
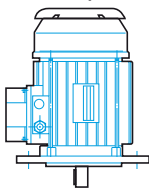
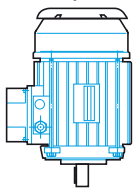
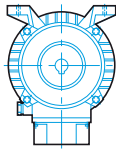
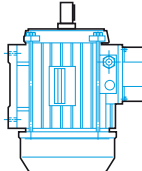
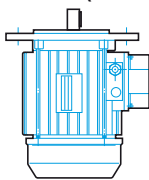
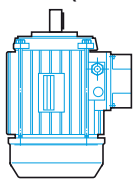
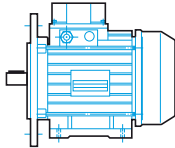
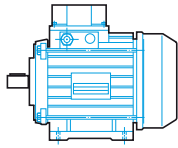
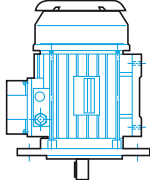
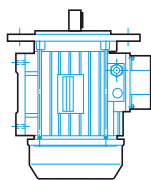
Motors with feet B3		Flange-mounted B5	Flange-mounted motors B14
<p>IM 1051 (IM B6)</p> 	<p>IM 1001 (IM B3)</p> 	<p>IM 3001 (IM B5)</p> 	<p>IM 3601 (IM B14)</p> 
<p>IM 1061 (IM B7)</p> 	<p>IM 1011 (IM V5)</p> 	<p>IM 3011 (IM V1)</p> 	<p>IM 3611 (IM V18)</p> 
<p>IM 1071 (IM B8)</p> 	<p>IM 1031 (IM V6)</p> 	<p>IM 3031 (IM V3)</p> 	<p>IM 3631 (IM V19)</p> 
<p>IM 2001 (IM B35)</p>  <p>B3/B5</p>	<p>IM 2101 (IM B34)</p>  <p>B3/B14</p>	<p>IM 2011 (IM V15)</p>  <p>V1/V5</p>	<p>IM 2031 (IM V36)</p>  <p>V3/V6</p>

## IP ratings and housings

IP55 standard protection rating of the motors.

Special executions are possible for harsh environments with greater or specific protection except for other indications on motor rating plate.

## Bearings

Bearings are pre-lubricated to IEC 160 with grease with a temperature range from -10°C till +110°C.  
 Can be applied bearings with special grease for high temperatures (-30°C to +140°C) / synthetic grease.  
 All are pre-loaded with corrugated tempered steel rings to eliminate residual clearance from the bearing.

Bearings					
Size	Poles	Cast iron		Alluminium	
		Shaft side	Fan side	Shaft side	Fan side
56	2 - 8	-	-	6201 2RS-C3	6201 2RS-C3
63	2 - 8	6201 ZZ-C3	6201 ZZ-C3	6201 2RS-C3	6201 2RS-C3
71	2 - 8	6202 ZZ-C3	6202 ZZ-C3	6202 2RS-C3	6202 2RS-C3
80	2 - 8	6204 ZZ-C3	6204 ZZ-C3	6204 2RS-C3	6204 2RS-C3
90	2 - 8	6205 ZZ-C3	6205 ZZ-C3	6205 2RS-C3	6205 2RS-C3
100	2 - 8	6206 ZZ-C3	6206 ZZ-C3	6206 2RS-C3	6206 2RS-C3
112	2 - 8	6306 ZZ-C3	6306 ZZ-C3	6206 2RS-C3	6206 2RS-C3
132	2 - 8	6308 ZZ-C3	6308 ZZ-C3	6208 2RS-C3	6208 2RS-C3
160	2 - 8	6309 ZZ-C3	6309 ZZ-C3	6309 2RS-C3	6309 2RS-C3
180	2 - 8	6311 - C3	6311 - C3	-	-
200	2 - 8	6312 - C3	6312 - C3	-	-
225	2 - 8	6313 - C3	6313 - C3	-	-
250	2 - 8	6314 - C3	6314 - C3	-	-
with greaser 280	2	6314 - C3	6314 - C3	-	-
	4 - 8	6317 - C3	6317 - C3	-	-
315	2	6317 - C3	6317 - C3	-	-
	4 - 10	NU 319 E	6319 - C3	-	-
355	2	6319 - C3	6319 - C3	-	-
	4 - 10	NU 322 E	6322 - C3	-	-

Bearing series NU upon request from size 160 to 280

Oil seal					
Size	Poles	Cast iron		Alluminium	
		Shaft side	Fan side	Shaft side	Fan side
56	2 - 8	-	-	12 x 25 x 7	12 x 25 x 7
63	2 - 8	12 x 25 x 7	12 x 25 x 7	12 x 25 x 7	12 x 25 x 7
71	2 - 8	15 x 30 x 7	15 x 30 x 7	15 x 30 x 7	15 x 30 x 7
80	2 - 8	20 x 35 x 7	20 x 35 x 7	20 x 35 x 7	20 x 35 x 7
90	2 - 8	25 x 40 x 7	25 x 40 x 7	25 x 40 x 7	25 x 40 x 7
100	2 - 8	30 x 47 x 7	30 x 47 x 7	30 x 47 x 7	30 x 47 x 7
112	2 - 8	30 x 47 x 7	30 x 47 x 7	30 x 47 x 7	30 x 47 x 7
132	2 - 8	40 x 62 x 7	40 x 62 x 7	40 x 62 x 7	40 x 62 x 7
160	2 - 8	45 x 62 x 12	45 x 62 x 12	45 x 62 x 12	45 x 62 x 12
180	2 - 8	55 x 75 x 12	55 x 75 x 12	-	-
200	2 - 8	60 x 80 x 12	60 x 80 x 12	-	-
225	2 - 8	65 x 90 x 12	65 x 90 x 12	-	-
250	2 - 8	70 x 90 x 12	70 x 90 x 12	-	-
280	2	80 x 110 x 12	80 x 110 x 12	-	-
	4 - 8	85 x 100 x 10	85 x 100 x 10	-	-
315	2	95 x 120 x 12	95 x 120 x 12	-	-
	4 - 10	95 x 120 x 12	95 x 120 x 12	-	-
355	2	95 x 120 x 12	95 x 120 x 12	-	-
	4 - 10	95 x 120 x 12	95 x 120 x 12	-	-

## Electrical specifications

### Stator winding insulation (per EN 60034-1 and IEC 34-1)

Top quality insulating materials are used in the windings. The ambient temperature considered is 40°C. The motor has an overall standard temperature insulation rating of class F. In standard configurations, the copper wire is insulated by a double layer of insulating enamel. Insulation in slot, between copper and iron, is achieved with a film that wraps completely the coil side.

In all the motors the phases are insulated between each other with an extra film, which protects from possible tension peaks that could happen during working under inverter.

Once the winding is finished, it is further impregnated with insulating paint and hardened by kiln firing to compact the entire unit, providing high resistance to electrical, mechanical and chemical stress.

Below is a graph showing the operating temperatures possible for stator windings based on the insulation rating shown on the machine plate.

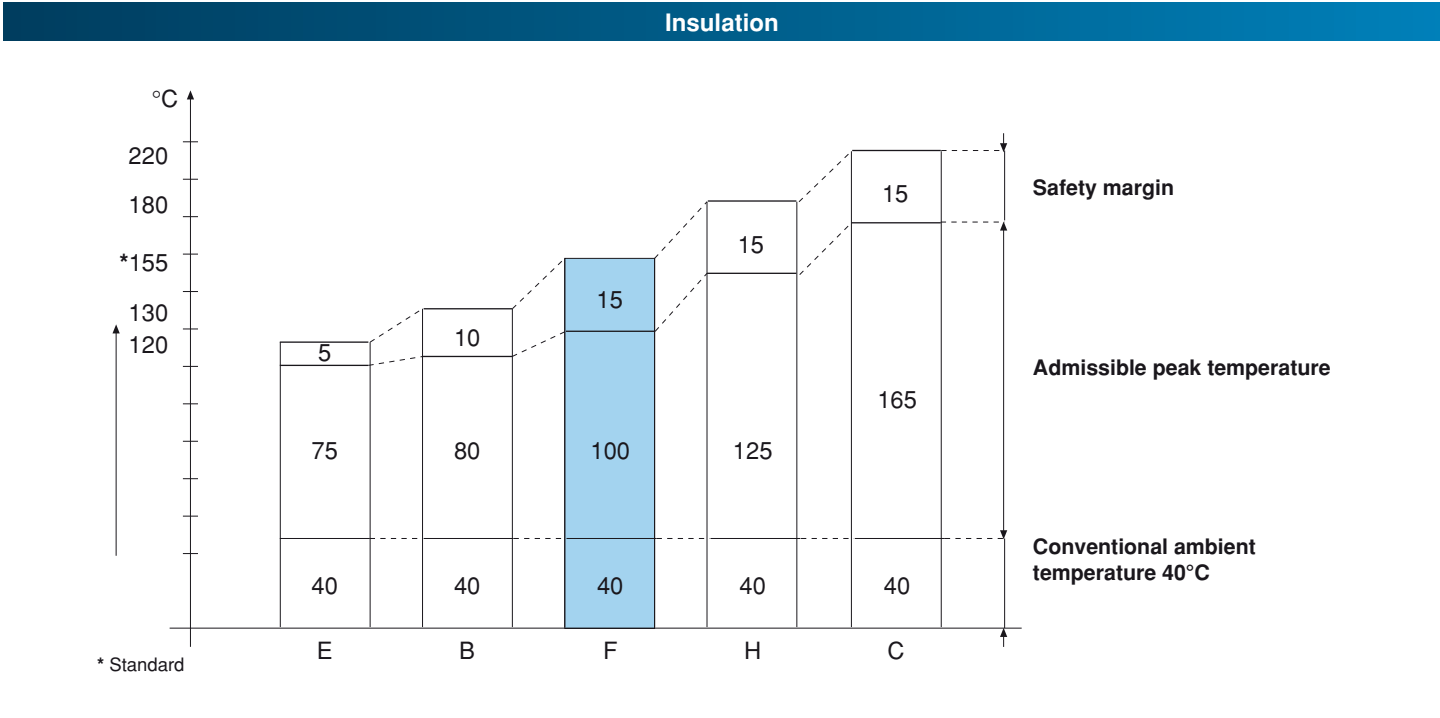

### Voltages and frequencies (per CEI EN 60034-1)

Neri three-phase and single phase motors can run at a voltage different from the rated one, with a margin of ± 10% short term (performance variations are possible and more significant for the single phase).

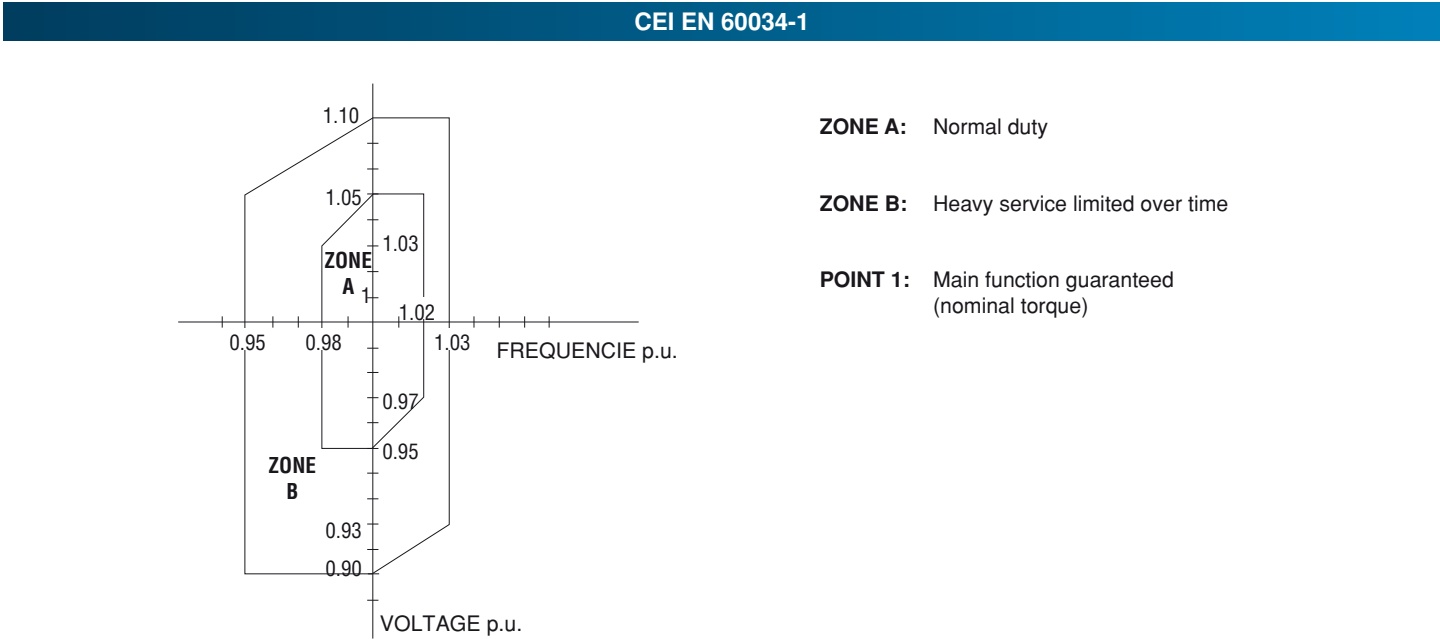

The table below shows the voltages at which a motor manufactured at the rated voltage may correctly run (approximately). Consult NERI MOTORI for any voltages not listed.

Rated voltages [V] [Hz]		Usable voltages [V] [Hz] (Zone A - Tab. 11)
230/400/50	277/480/60	240/415/50 - 220/380/50 - 265/460/60 - 255/440/60
190/330/50	220/380/60	200/346/60 - 208/360/60 - 230/400/60
208/360/50	254/440/60	200/346/50 - 240/415/60
400/690/50	480/830/60	380/660/50 - 415/717/50

### Frequencies at 60 Hz

All electrical data in this catalogue refer to three-phase wound motors at 50 Hz.

These may be connected to 60 Hz, taking into account the multiplier coefficients in the table below:

Rated voltage at 50 Hz	Volt at 60 Hz	Rated power W	rpm	In	Ia / In	Ca / Cn	Cmax / Cn
220	220	1,00	1,2	1,20	0,80	0,80	0,80
220	230	1,05	1,2	1,15	0,85	0,85	0,85
220	240	1,06	1,2	1,10	0,87	0,87	0,87
* 230	230	1,00	1,2	1,20	0,80	0,80	0,80
230	240	1,10	1,2	1,15	0,90	0,90	0,90
230	260	1,20	1,2	1,00	1,00	1,00	1,00
* 400	400	1,00	1,2	1,20	0,80	0,80	0,80
400	440	1,06	1,2	1,10	0,87	0,87	0,87
400	460	1,20	1,2	1,00	1,00	1,00	1,00
400	480	1,25	1,2	1,00	1,10	1,10	1,10
440	440	1,00	1,2	1,20	0,80	0,80	0,80
500	500	1,00	1,2	1,20	0,80	0,80	0,80
500	550	1,06	1,2	1,10	0,87	0,87	0,87

Where you can notice\* that a motor wound at 50 Hz can work at 60 Hz with the same rated voltage, power (W), with a 1,2 increase of rpm and rated current in, also a 0,8 reduction of starting current Ia / In, of the starting torque Ca / Cn and of the maximum torque Cmax / Cn.

### Legend

**rpm** = R.p.m.

**I<sub>s</sub> / I<sub>n</sub>** =  $\frac{\text{Starting current}}{\text{Rated current}}$

**C<sub>s</sub> / C<sub>n</sub>** =  $\frac{\text{Starting torque}}{\text{Rated torque}}$

**C<sub>max</sub> / C<sub>n</sub>** =  $\frac{\text{Maximum torque}}{\text{Rated torque}}$

**I<sub>n</sub>** = Rated current

# THREE-PHASE INDUCTION MOTORS MR TYPE

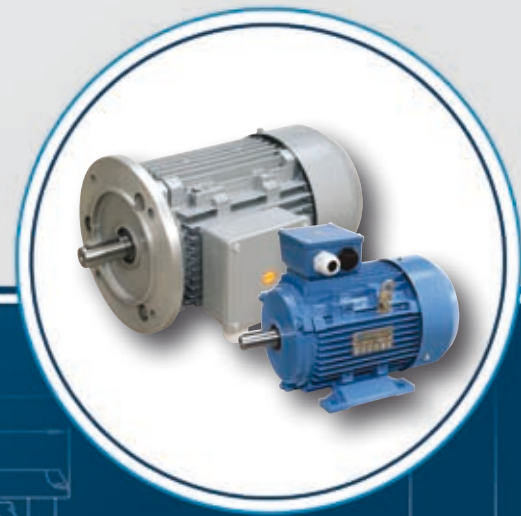
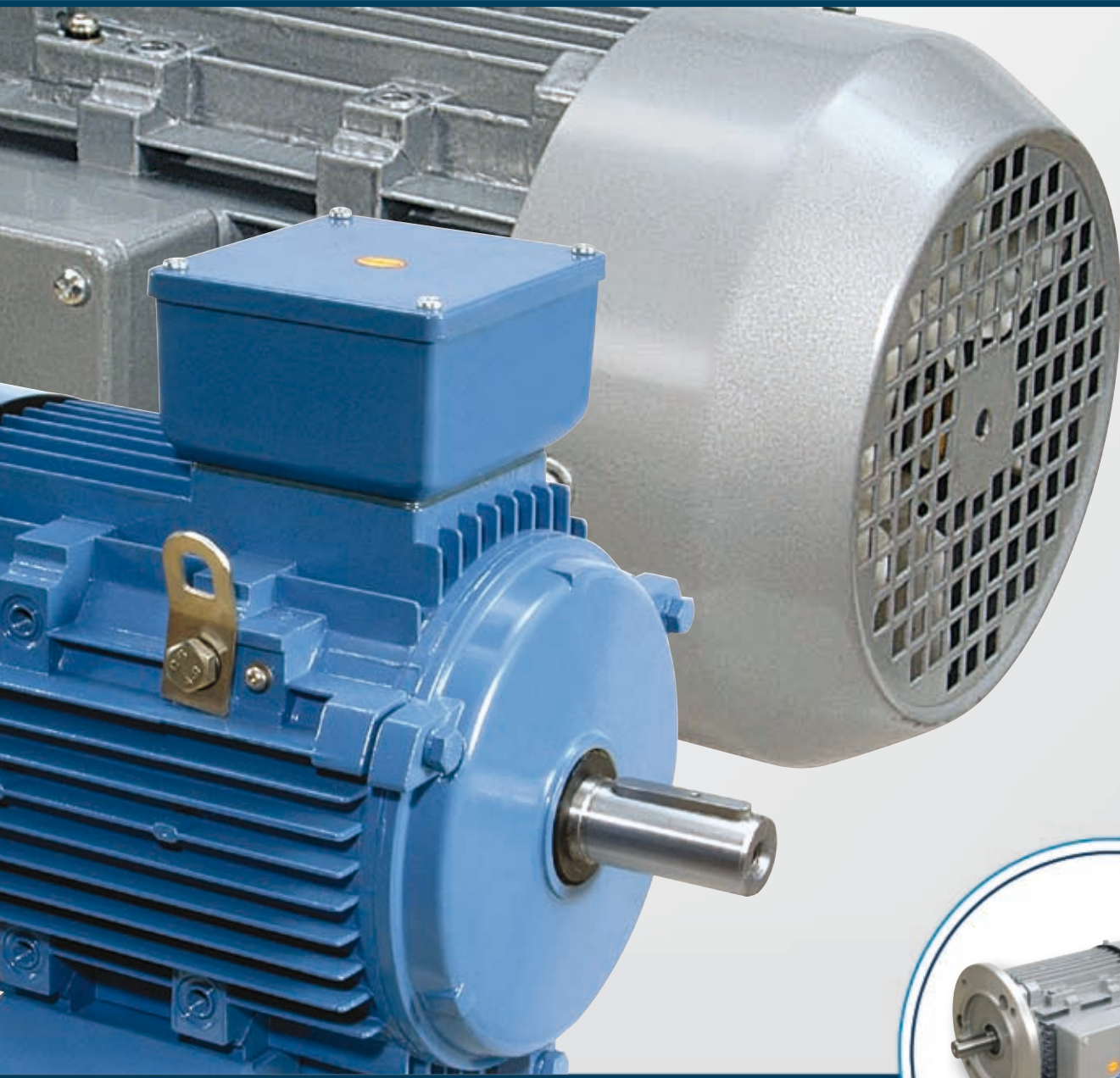

## THREE-PHASE INDUCTION MOTORS MR TYPE

The asynchronous three-phase have been specifically designed with use at variable speed, torque and power variables.

It has therefore been possible to achieve excellent results in terms of limited temperatures and high performance even when controlled by inverters thanks to the use of high-quality materials.

Motors are painted.

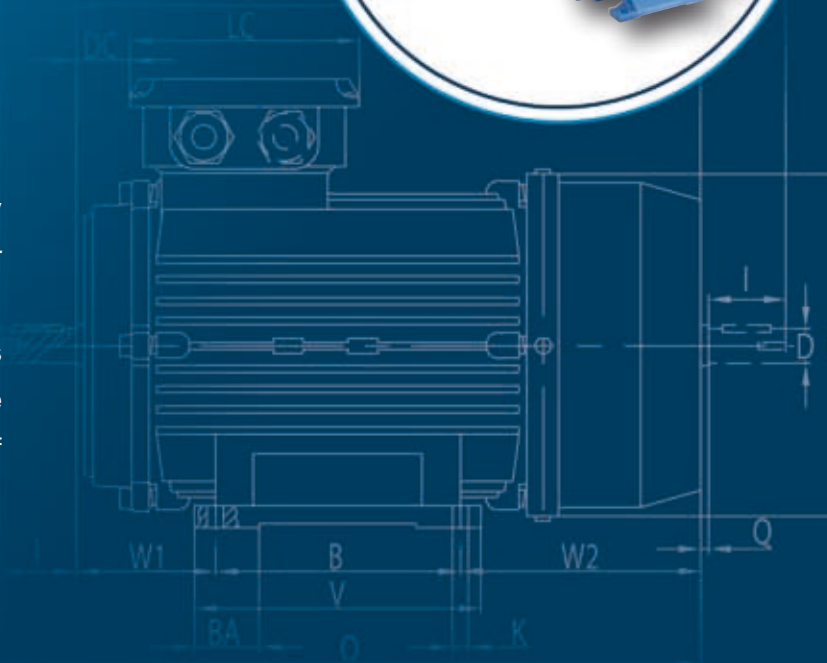

## 2 POLES 3000 rpm – Volt 230/400/50 Hz

Size	Power		Rpm	In (V 400)	Is / In	Cn (Nm)	Cs / Cn	Cmax / Cn	Rend. % η	Cosφ %	LwA (dB)	Weight kg	J Kgm <sup>2</sup>
	kW	HP											
<b>Alluminium motors</b>													
56A	0,09	0,12	2750	0,30	5,2	0,31	2,1	2,2	62,0	0,70	57	3,6	0,00018
56B	0,12	0,18	2750	0,36	5,2	0,41	2,1	2,2	67,0	0,72	57	3,9	0,00023
63A	0,18	0,25	2720	0,50	5,5	0,61	2,2	2,3	65,0	0,80	58	4,8	0,00031
63B	0,25	0,37	2720	0,66	5,5	0,96	2,2	2,3	68,0	0,81	58	5,1	0,00060
71A	0,37	0,50	2740	0,94	6,1	1,26	2,2	2,3	70,0	0,81	61	6,0	0,00075
71B	0,55	0,75	2740	1,33	6,1	1,88	2,2	2,3	73,0	0,82	61	6,5	0,00090
80A	0,75	1,00	2840	1,73	6,1	2,54	2,2	2,3	75,1	0,83	64	8,7	0,00120
80B	1,10	1,50	2840	2,45	7,0	3,72	2,2	2,3	77,0	0,84	64	9,5	0,00140
90S	1,50	2,00	2840	3,26	7,0	5,14	2,2	2,3	79,0	0,84	69	11,8	0,00290
90L	2,20	3,00	2840	4,61	7,0	7,40	2,2	2,3	81,1	0,85	69	13,5	0,00550
100L	3,00	4,00	2860	6,01	7,5	9,95	2,2	2,3	82,8	0,87	73	21,0	0,01090
112M	4,00	5,50	2880	7,77	7,5	13,22	2,2	2,3	84,4	0,88	74	28,0	0,01260
132SA	5,50	7,50	2900	10,50	7,5	18,11	2,2	2,3	85,9	0,88	77	39,0	0,03770
132SB	7,50	10,00	2900	14,10	7,5	24,70	2,2	2,3	87,2	0,88	77	44,5	0,04990
<b>Cast iron motors</b>													
160MA	11,00	15,00	2930	20,20	7,5	35,85	2,2	2,3	88,5	0,89	86	110,0	0,03770
160MB	15,00	20,00	2930	27,20	7,5	48,89	2,2	2,3	89,5	0,89	86	120,0	0,04990
160L	18,50	25,00	2930	32,90	7,5	60,30	2,0	2,3	90,2	0,90	86	135,0	0,05500
180M	22,00	30,00	2940	38,90	7,5	71,46	2,0	2,3	90,7	0,90	89	165,0	0,07500
200LA	30,00	40,00	2950	52,60	7,5	97,12	2,0	2,3	91,5	0,90	92	218,0	0,12400
200LB	37,00	50,00	2950	64,40	7,5	119,78	2,0	2,3	92,2	0,90	92	230,0	0,13900
225M	45,00	60,00	2960	77,90	7,5	144,70	2,0	2,3	92,7	0,90	92	280,0	0,23300
250M	55,00	75,00	2965	94,60	7,5	176,85	2,0	2,3	93,2	0,90	93	365,0	0,31200
280S	75,00	100,00	2970	128,00	7,5	241,16	2,0	2,3	93,8	0,90	94	495,0	0,57900
280M	90,00	125,00	2970	152,00	7,1	289,39	2,0	2,3	94,0	0,91	94	565,0	0,67500
315S	110,00	150,00	2975	185,00	7,1	352,51	1,8	2,2	94,2	0,91	96	890,0	1,80000
315M	132,00	180,00	2975	221,00	7,1	423,02	1,8	2,2	94,6	0,91	96	980,0	1,82000
315LA	160,00	220,00	2975	265,00	7,1	512,75	1,8	2,2	94,8	0,92	99	1055,0	2,08000
315LB	200,00	270,00	2975	330,00	7,1	640,94	1,8	2,2	95,0	0,92	99	1110,0	2,38000
355M	250,00	340,00	2980	411,00	7,1	799,83	1,8	2,2	95,4	0,92	103	1900,0	3,00000
355L	315,00	430,00	2980	518,00	7,1	1007,90	1,8	2,2	95,5	0,92	103	2300,0	3,50000

## 4 POLES 1500 rpm – Volt 230/400/50 Hz

<b>Alluminium motors</b>													
Size	Power		Rpm	In (V 400)	Is / In	Cn (Nm)	Cs / Cn	Cmax / Cn	Rend. % η	Cosφ %	LwA (dB)	Weight kg	J Kgm <sup>2</sup>
	kW	HP											
56A	0,06	0,09	1325	0,27	4,0	0,43	2,0	2,1	56,0	0,58	48	3,6	0,0003
56B	0,09	0,12	1325	0,37	4,0	0,64	2,0	2,1	58,0	0,61	48	3,9	0,0004
63A	0,12	0,18	1310	0,42	4,4	0,84	2,1	2,2	57,0	0,72	48	4,8	0,0005
63B	0,18	0,25	1310	0,95	4,4	1,26	2,1	2,2	60,0	0,73	48	5,1	0,0006
71A	0,25	0,37	1330	0,75	5,2	1,73	2,1	2,2	65,0	0,74	53	6,0	0,0008
71B	0,37	0,50	1330	1,06	5,2	2,56	2,1	2,2	67,0	0,75	53	6,3	0,0013
80A	0,55	0,75	1390	1,49	5,2	3,75	2,3	2,3	71,1	0,75	58	9,4	0,0018
80B	0,75	1,00	1390	1,95	6,0	5,11	2,3	2,3	73,1	0,76	58	10,8	0,0021
90S	1,10	1,50	1390	2,70	6,0	7,50	2,3	2,3	76,3	0,77	59	12,0	0,0023
90L	1,50	2,00	1390	3,49	6,0	10,23	2,3	2,3	78,6	0,79	59	13,8	0,0027
100LA	2,20	3,00	1410	4,83	7,0	14,80	2,3	2,3	81,2	0,81	61	20,8	0,0054
100LB	3,00	4,00	1410	6,39	7,0	20,18	2,3	2,3	82,7	0,82	61	23,5	0,0067
112M	4,00	5,50	1435	8,35	7,0	26,53	2,3	2,3	84,3	0,82	62	29,5	0,0095
132S	5,50	7,50	1440	11,10	7,0	36,48	2,3	2,3	85,8	0,83	69	41,0	0,0214
132M	7,50	10,00	1440	14,80	7,0	49,74	2,3	2,3	87,1	0,84	69	47,5	0,0296
<b>Cast iron motors</b>													
160M	11,00	15,00	1460	21,40	7,0	71,59	2,2	2,3	88,5	0,84	75	118,0	0,07470
160L	15,00	20,00	1460	28,50	7,5	89,12	2,2	2,3	89,5	0,85	75	132,0	0,09180
180M	18,50	25,00	1470	34,50	7,5	120,19	2,2	2,3	90,1	0,86	76	164,0	0,13900
180L	22,00	30,00	1470	40,80	7,5	142,93	2,2	2,3	90,6	0,86	76	182,0	0,15800
200L	30,00	40,00	1470	55,00	7,2	160,96	2,2	2,3	91,5	0,86	79	245,0	0,26200
225S	37,00	50,00	1475	66,70	7,2	198,51	2,2	2,3	92,1	0,87	81	258,0	0,40600
225M	45,00	60,00	1475	80,60	7,2	290,37	2,2	2,3	92,6	0,87	81	290,0	0,46900
250M	55,00	75,00	1480	98,00	7,2	354,90	2,2	2,3	93,1	0,87	83	388,0	0,66000
280S	75,00	100,00	1480	133,00	7,2	483,95	2,2	2,3	93,7	0,87	86	510,0	1,12000
280M	90,00	125,00	1480	159,00	7,2	578,79	2,2	2,3	94,0	0,87	86	606,0	1,46000
315S	110,00	150,00	1480	191,00	6,9	707,41	2,1	2,2	94,6	0,88	93	910,0	3,11000
315M	132,00	180,00	1480	228,00	6,9	848,89	2,1	2,2	94,9	0,88	93	1000,0	3,62000
315LA	160,00	220,00	1480	273,00	6,9	1029,00	2,1	2,2	95,0	0,89	97	1055,0	4,13000
315LB	200,00	270,00	1480	341,00	6,9	1286,20	2,1	2,2	95,0	0,89	97	1128,0	4,73000
355M	250,00	340,00	1490	421,00	6,9	1602,40	2,1	2,2	95,3	0,90	101	1700,0	6,50000
355L	315,00	430,00	1490	530,00	6,9	2019,00	2,1	2,2	95,3	0,90	101	1900,0	8,20000

## 6 POLES 1000 rpm – Volt 230/400/50 Hz

Size	Power		Rpm	In (V 400)	Is / In	Cn (Nm)	Cs / Cn	Cmax / Cn	Rend. % $\eta$	Cos $\phi$ %	LwA (dB)	Weight kg	J Kgm <sup>2</sup>
	kW	HP											
<b>Alluminium motors</b>													
71A	0,18	0,25	850	0,70	4,0	1,91	1,9	2,0	56,0	0,66	49	6,0	0,00110
71B	0,25	0,37	850	0,90	4,0	2,65	1,9	2,0	59,0	0,68	49	6,3	0,00140
80A	0,37	0,50	885	1,23	4,7	3,93	1,9	2,0	62,0	0,70	51	8,9	0,00160
80B	0,55	0,75	885	1,69	4,7	5,84	1,9	2,1	65,0	0,72	51	10,4	0,00190
90S	0,75	1,00	910	2,18	5,5	7,87	2,0	2,1	69,0	0,72	54	12,1	0,00290
90L	1,10	1,50	910	3,02	5,5	11,54	2,0	2,1	72,1	0,73	54	13,7	0,00350
100L	1,50	2,00	920	3,79	5,5	15,24	2,0	2,1	76,1	0,75	58	23,0	0,00690
112M	2,20	3,00	935	5,28	6,5	22,35	2,1	2,1	79,2	0,76	62	28,2	0,01400
132S	3,00	4,00	960	7,03	6,5	29,84	2,1	2,1	81,1	0,76	66	40,3	0,02860
132MA	4,00	5,50	960	9,25	6,5	39,79	2,1	2,1	82,1	0,76	66	43,0	0,03570
132MB	5,50	7,50	960	12,30	6,5	54,71	2,1	2,1	84,1	0,77	66	47,2	0,04490
<b>Cast iron motors</b>													
160M	7,50	10,00	970	16,30	6,5	73,84	2,0	2,1	86,1	0,77	73	118,0	0,08100
160L	11,00	15,00	970	23,20	6,5	108,30	2,0	2,1	87,6	0,78	73	145,0	0,11600
180L	15,00	20,00	970	30,00	7,0	147,68	2,1	2,1	89,1	0,81	73	178,0	0,20700
200LA	18,50	25,00	980	36,60	7,0	182,14	2,1	2,0	90,1	0,81	76	200,0	0,31500
200LB	22,00	30,00	980	42,50	7,0	216,60	2,1	2,0	90,1	0,83	76	228,0	0,36000
225M	30,00	40,00	980	56,30	7,0	292,35	2,0	2,0	91,6	0,84	76	265,0	0,54700
250M	37,00	50,00	980	67,40	7,0	360,26	2,1	2,1	92,1	0,86	78	370,0	0,84300
280S	45,00	60,00	980	81,60	7,0	438,52	2,1	2,0	92,6	0,86	80	490,0	1,39000
280M	55,00	75,00	980	99,40	7,0	535,97	2,1	2,0	92,9	0,86	80	540,0	1,65000
315S	75,00	100,00	985	134,00	7,0	730,87	2,0	2,0	93,6	0,86	85	900,0	4,11000
315M	90,00	125,00	985	161,00	6,7	872,59	2,0	2,0	93,9	0,86	85	980,0	4,78000
315LA	110,00	150,00	985	196,00	6,7	1066,50	2,0	2,0	94,1	0,86	85	1045,0	5,45000
315LB	132,00	180,00	985	232,00	6,7	1279,80	2,0	2,0	94,3	0,87	85	1100,0	6,12000
355MA	160,00	220,00	990	277,00	6,7	1543,40	1,9	2,0	94,6	0,88	92	1550,0	9,50000
355MB	200,00	270,00	990	347,00	6,7	1913,30	1,9	2,0	94,6	0,88	92	1600,0	10,40000

## 8 POLES 750 rpm – Volt 230/400/50 Hz

<b>Alluminium motors</b>													
80A	0,18	0,25	645	0,84	3,3	2,50	1,8	1,9	51,0	0,61	48	8,9	0,00250
80B	0,25	0,37	645	1,10	3,3	3,50	1,8	1,9	54,0	0,61	48	10,4	0,00300
90S	0,37	0,50	670	1,41	4,0	5,10	1,8	1,9	62,0	0,61	53	12,1	0,00510
90L	0,55	0,75	670	2,07	4,0	7,60	1,8	2,0	63,0	0,61	53	13,7	0,00650
100LA	0,75	1,00	680	2,28	4,0	10,20	1,8	2,0	71,0	0,67	56	23,0	0,00950
100LB	1,10	1,50	680	3,15	5,0	15,00	1,8	2,0	73,0	0,69	56	25,1	0,01100
112M	1,50	2,00	690	4,18	5,0	20,50	1,8	2,0	75,0	0,69	59	28,2	0,02450
132S	2,20	3,00	705	5,73	6,0	29,60	1,8	2,0	78,0	0,71	61	40,3	0,03140
132M	3,00	4,00	705	7,51	6,0	40,40	1,8	2,0	79,0	0,73	61	45,0	0,03950
<b>Cast iron motors</b>													
160MA	4,00	5,50	720	9,76	6,0	53,06	1,9	2,0	81,0	0,73	68	105,0	0,07530
160MB	5,50	7,50	720	12,90	6,0	72,59	2,0	2,0	83,0	0,74	68	115,0	0,09310
160L	7,50	10,00	720	16,90	6,0	99,50	2,0	2,0	85,5	0,75	68	145,0	0,12600
180L	11,00	15,00	730	23,90	6,0	143,90	2,0	2,0	87,5	0,76	70	160,0	0,20300
200L	15,00	20,00	730	32,40	6,6	196,23	2,0	2,0	88,0	0,76	73	228,0	0,39900
225S	18,50	25,00	730	39,00	6,6	242,02	1,9	2,0	90,0	0,76	73	242,0	0,49100
225M	22,00	30,00	730	45,00	6,6	287,81	1,9	2,0	90,5	0,78	73	265,0	0,54700
250M	30,00	40,00	735	60,20	6,6	382,47	1,9	2,0	91,0	0,79	75	368,0	0,83400
280S	37,00	50,00	735	73,90	6,6	484,04	1,9	2,0	91,5	0,79	76	472,0	1,93000
280M	45,00	60,00	735	89,40	6,6	580,74	1,8	2,0	92,0	0,79	76	538,0	3,65000
315S	55,00	75,00	735	106,00	6,6	709,80	1,8	2,0	92,8	0,81	82	900,0	4,79000
315M	75,00	100,00	735	144,00	6,6	967,91	1,8	2,0	93,0	0,81	82	1000,0	5,58000
315LA	90,00	125,00	735	169,00	6,6	1161,49	1,8	2,0	93,8	0,82	82	1055,0	6,37000
315LB	110,00	150,00	735	206,00	6,4	1419,60	1,8	2,0	94,0	0,82	82	1118,0	7,23000
355MA	132,00	180,00	740	248,00	6,4	1692,08	1,8	2,0	93,7	0,82	90	2000,0	7,90000
355MB	160,00	220,00	740	299,00	6,4	2051,00	1,8	2,0	94,2	0,82	90	2150,0	10,30000
355L	200,00	270,00	740	368,00	6,4	2563,38	1,8	2,0	94,5	0,83	90	2250,0	12,30000

## B3 motor dimensions

IEC 56 ÷ 132

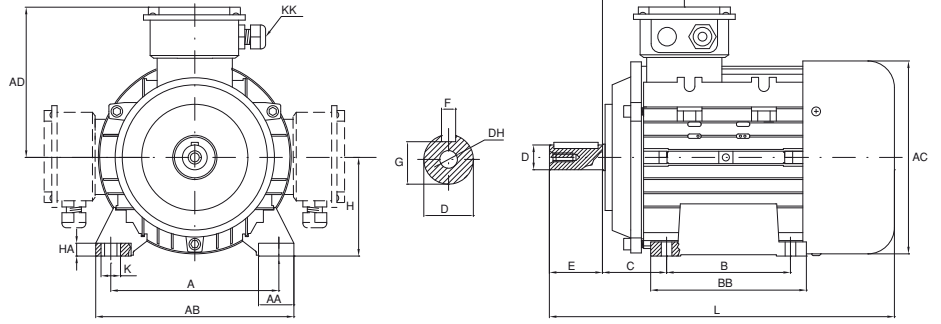

IEC 160 ÷ 355

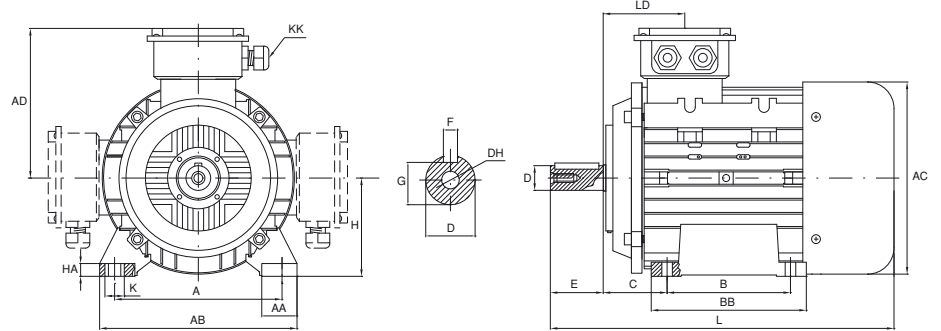

Size	Poles	Dimensions																		
		A	AA	B	C	D	E	F	G	H	K	AB	AC	AD	L	HA	KK	DH	BB	LD
<b>Alluminium motors</b>																				
56	2-4	90	23	71	36	9	20	3	7,2	56	5,8	115	110	100	199	7	1-M20x1,5	M4x12	88	-
63	2-4	100	24	80	40	11	23	4	8,5	63	7,0	135	130	111	217	7	1-M20x1,5	M4x12	100	-
71	2-4-6	112	26	90	45	14	30	5	11,0	71	7,0	150	145	118	245	8	1-M20x1,5	M5x12	110	-
80	2-4-6-8	125	35	100	50	19	40	6	15,5	80	10,0	165	175	134	287	9	1-M25x1,5	M6x16	125	-
90S	2-4-6-8	140	37	100	56	24	50	8	20,0	90	10,0	180	195	140	315	10	1-M25x1,5	M8x19	125	-
90L	2-4-6-8	140	37	125	56	24	50	8	20,0	90	10,0	180	195	140	340	10	1-M25x1,5	M8x19	150	-
100L	2-4-6-8	160	40	140	63	28	60	8	24,0	100	12,0	205	215	160	385	11	1-M32x1,5	M10x22	172	-
112M	2-4-6-8	190	41	140	70	28	60	8	24,0	112	12,0	230	240	178	400	12	2-M32x1,5	M10x22	181	-
132S	2-4-6-8	216	51	140	89	38	80	10	33,0	132	12,0	270	275	206	483	15	2-M32x1,5	M12x28	186	-
132M	2-4-6-8	216	51	178	89	38	80	10	33,0	132	12,0	270	275	206	510	15	2-M32x1,5	M12x28	224	-
<b>Cast iron motors</b>																				
160M	2	254	65	210	108	42	110	12	37,0	160	15,0	320	315	255	615	20	2-M40x1,5	M16x36	260	132,0
	4-6-8	254	65	210	108	42	110	12	37,0	160	15,0	320	315	255	615	20	2-M40x1,5	M16x36	260	135,0
160L	2	254	65	254	108	42	110	12	37,0	160	15,0	320	315	255	670	22	2-M40x1,5	M16x36	304	132,0
	4-6-8	254	65	254	108	42	110	12	37,0	160	15,0	320	315	255	670	22	2-M40x1,5	M16x36	304	135,0
180M	2	279	70	241	121	48	110	14	42,5	180	15,0	355	355	280	700	25	2-M40x1,5	M16x36	311	138,5
	4	279	70	279	121	48	110	14	42,5	180	15,0	355	355	280	740	28	2-M40x1,5	M16x36	349	136,5
180L	4-6-8	279	70	279	121	48	110	14	42,5	180	15,0	355	355	280	740	28	2-M40x1,5	M16x36	349	139,5
200L	2	318	70	305	133	55	110	16	49,0	200	19,0	395	397	305	770	30	2-M50x1,5	M20x42	369	149,5
	4-6-8	318	70	305	133	55	110	16	49,0	200	19,0	395	397	305	770	30	2-M50x1,5	M20x42	369	158,5
225S	4-8	356	75	286	149	60	140	18	53,0	225	19,0	435	445	335	815	28	2-M50x1,5	M20x42	368	156,5
225M	2	356	75	311	149	55	110	16	49,0	225	19,0	435	445	335	820	28	2-M50x1,5	M20x42	304	154,5
	4-6-8	356	75	311	149	60	140	18	53,0	225	19,0	435	445	335	845	28	2-M50x1,5	M20x42	304	156,5
250M	2	406	80	349	168	60	140	18	53,0	250	24,0	490	485	370	910	30	2-M63x1,5	M20x42	445	170,5
	4-6-8	406	80	349	168	65	140	18	58,0	250	24,0	490	485	370	910	30	2-M63x1,5	M20x42	445	172,5
280S	2	457	85	368	190	65	140	18	58,0	280	24,0	550	547	410	985	35	2-M63x1,5	M20x42	485	170,5
	4-6-8	457	85	368	190	75	140	20	67,5	280	24,0	550	547	410	985	35	2-M63x1,5	M20x42	485	179,0
280M	2	457	85	419	190	65	140	18	58,0	280	24,0	550	547	410	1035	35	2-M63x1,5	M20x42	536	170,5
	4-6-8	457	85	419	190	75	140	20	67,5	280	24,0	550	547	410	1035	35	2-M63x1,5	M20x42	536	179,0
315S	2	508	120	406	216	65	140	18	58,0	315	28,0	635	620	530	1160	45	2-M63x1,5	M20x42	570	211,0
	4-6-8	508	120	406	216	80	170	22	71,0	315	28,0	635	620	530	1270	45	2-M63x1,5	M20x42	570	211,0
315M	2	508	120	457	216	65	140	18	58,0	315	28,0	635	620	530	1190	45	2-M63x1,5	M20x42	680	211,0
	4-6-8	508	120	457	216	80	170	22	71,0	315	28,0	635	620	530	1300	45	2-M63x1,5	M20x42	680	211,0
315L	2	508	120	508	216	65	140	18	58,0	315	28,0	635	620	530	1190	45	2-M63x1,5	M20x42	680	211,0
	4-6-8	508	120	508	216	80	170	22	71,0	315	28,0	635	620	530	1300	45	2-M63x1,5	M20x42	680	211,0
355M	6-8	610	116	560	254	95	170	25	86,0	355	28,0	730	698	655	1530	52	2-M63x1,5	M20x42	760	234,0
355L	8	610	116	630	254	95	170	25	86,0	355	28,0	730	698	655	1530	52	2-M63x1,5	M20x42	760	234,0



## B5 motor dimensions

IEC 56 ÷ 200

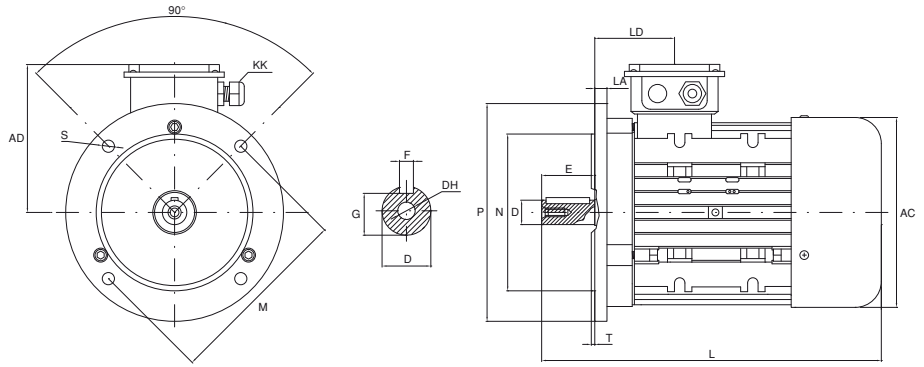

IEC 225 ÷ 355

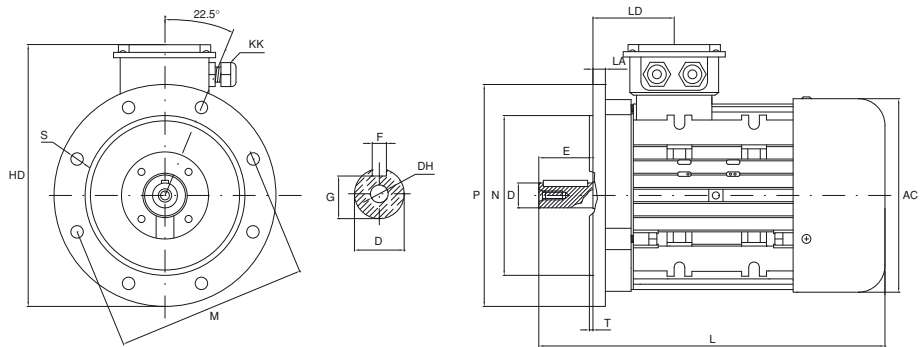

Size	Dimensions													Overall size					
	HA	AC	AD	B	C	D	DH	E	F	G	H	K	KK	L	M	N	P	S	T
<b>Alluminium motors</b>																			
56	7	110	100	71	36	9	M4x12	20	3	7,2	56	5,8	1-M20x1,5	199	100	80	120	7	3,0
63	7	130	111	80	40	11	M4x12	23	4	8,5	63	7,0	1-M20x1,5	217	115	95	140	10	3,0
71	8	145	118	90	45	14	M5x12	30	5	11,0	71	7,0	1-M20x1,5	245	130	110	160	12	3,5
80	9	175	134	100	50	19	M6x16	40	6	15,5	80	7,0	1-M25x1,5	287	165	130	200	12	3,5
90S	10	195	140	100	56	24	M8x19	50	8	20,0	90	10,0	1-M25x1,5	315	165	130	200	12	3,5
90L	10	195	140	125	56	24	M8x19	50	8	20,0	90	10,0	1-M25x1,5	340	165	130	200	12	4,0
100L	11	215	160	140	63	28	M10x22	50	8	24,0	100	12,0	1-M32x1,5	385	215	180	250	15	4,0
112M	12	240	178	140	70	28	M10x22	60	8	24,0	112	12,0	2-M32x1,5	400	215	180	250	15	4,0
132S	15	275	206	140	89	38	M12x28	80	10	33,0	132	12,0	2-M32x1,5	483	265	230	300	15	4,0
132M	15	275	206	178	89	38	M12x28	80	10	33,0	132	12,0	2-M32x1,5	510	265	230	300	15	4,0

Size	Poles	Dimensions											AC	HD	L	LD	LA	DH
		D	E	F	G	M	N	P	S	T	holes flange							
160M	2-4-6-8	42	110	12	37,0	300	250	350	19	5	4	315	420	615	146,0	15	M16x36	
160L	2-4-6-8	42	110	12	37,0	300	250	350	19	5	4	315	420	670	146,0	15	M16x36	
180M	2-4-6-8	48	110	14	42,5	300	250	350	19	5	4	355	455	700	158,0	15	M16x36	
180L	4-6-8	48	110	14	42,5	300	250	350	19	5	4	355	455	740	158,0	15	M16x36	
200L	2-4-6-8	55	110	16	49,0	350	300	400	19	5	4	397	505	770	186,0	17	M20x42	
225S	4-8	60	140	18	53,0	400	350	450	19	5	8	445	555	815	189,0	20	M20x42	
225M	2	55	110	16	49,0	400	350	450	19	5	8	445	555	820	189,0	20	M20x42	
	4-6-8	60	140	18	53,0	400	350	450	19	5	8	445	555	845	189,0	20	M20x42	
250M	2	60	140	18	53,0	500	450	550	19	5	8	485	615	910	116,0	22	M20x42	
	4-6-8	65	140	18	58,0	500	450	550	19	5	8	485	615	910	116,0	22	M20x42	
280S	2	65	140	18	58,0	500	450	550	19	5	8	547	680	985	215,5	22	M20x42	
	4-6-8	75	140	20	67,5	500	450	550	19	5	8	547	680	985	215,5	22	M20x42	
280M	2	65	140	18	58,0	500	450	550	19	5	8	547	680	1035	215,5	22	M20x42	
	4-6-8	75	140	20	67,5	500	450	550	19	5	8	547	680	1035	215,5	22	M20x42	
315S	2	65	140	18	58,0	600	550	660	24	6	8	620	845	1160	257,0	22	M20x42	
	4-6-8	80	170	22	71,0	600	550	660	24	6	8	620	845	1270	257,0	22	M20x42	
315M	2	65	140	18	58,0	600	550	660	24	6	8	620	845	1190	257,0	22	M20x42	
	4-6-8	80	170	22	71,0	600	550	660	24	6	8	620	845	1300	257,0	22	M20x42	
315L	2	65	140	18	58,0	600	550	660	24	6	8	620	845	1190	257,0	22	M20x42	
	4-6-8	80	170	22	71,0	600	550	660	24	6	8	620	845	1300	257,0	22	M20x42	
355M	6-8	95	170	25	86,0	740	680	800	24	6	8	698	1010	1530	284,0	25	M20x42	
355L	6-8	95	170	25	86,0	740	680	800	24	6	8	698	1010	1530	284,0	25	M20x42	

## B14 motor dimensions

IEC 56 ÷ 100

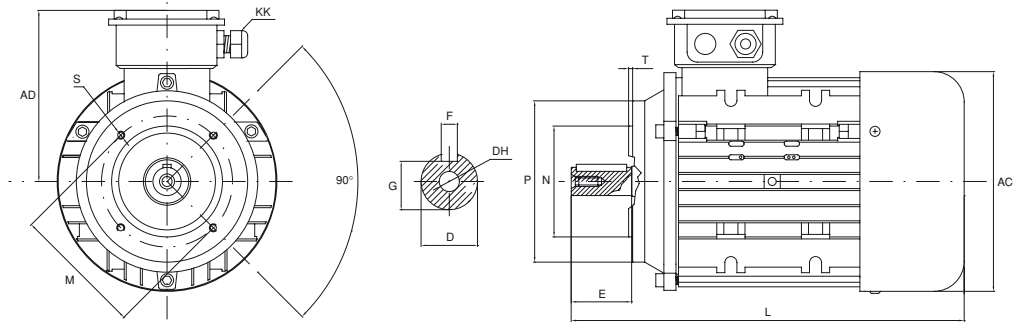

IEC 112 ÷ 132

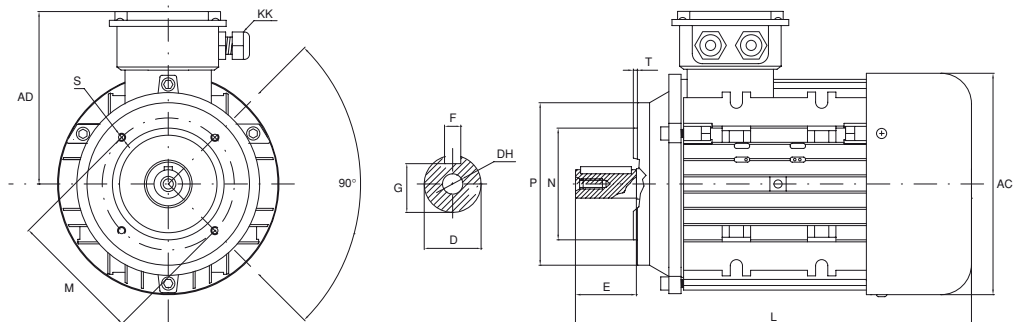

Size	AC	AD	D	DH	E	F	G	KK	L	M	N	P	S	T
<b>Alluminium motors</b>														
56	110	100	9	M4x12	20	3	7,2	1-M20x1,5	199	65	50	80	M5	2,5
63	130	111	11	M4x12	23	4	8,5	1-M20x1,5	217	75	60	90	M5	2,5
71	145	118	14	M5x12	30	5	11,0	1-M20x1,5	245	85	70	105	M6	2,5
80	175	134	19	M6x16	40	6	15,5	1-M25x1,5	297	100	80	120	M6	3,0
90S	195	140	24	M8x19	50	8	20,0	1-M25x1,5	315	115	95	140	M8	3,0
90L	195	140	24	M10x22	50	8	20,0	1-M25x1,5	340	115	95	140	M8	3,0
100L	215	160	28	M10x22	60	8	24,0	1-M32x1,5	385	130	110	160	M8	3,5
112M	240	178	28	M10x22	60	8	24,0	2-M32x1,5	400	130	110	160	M8	3,5
132S	275	206	28	M12x28	80	10	33,0	2-M40x1,5	483	165	130	200	M10	3,5
132M	275	206	38	M12x28	80	10	33,0	2-M40x1,5	510	165	130	200	M10	3,5

# THREE-PHASE INDUCTION SELF BRAKE MOTORS MK AND MH TYPES

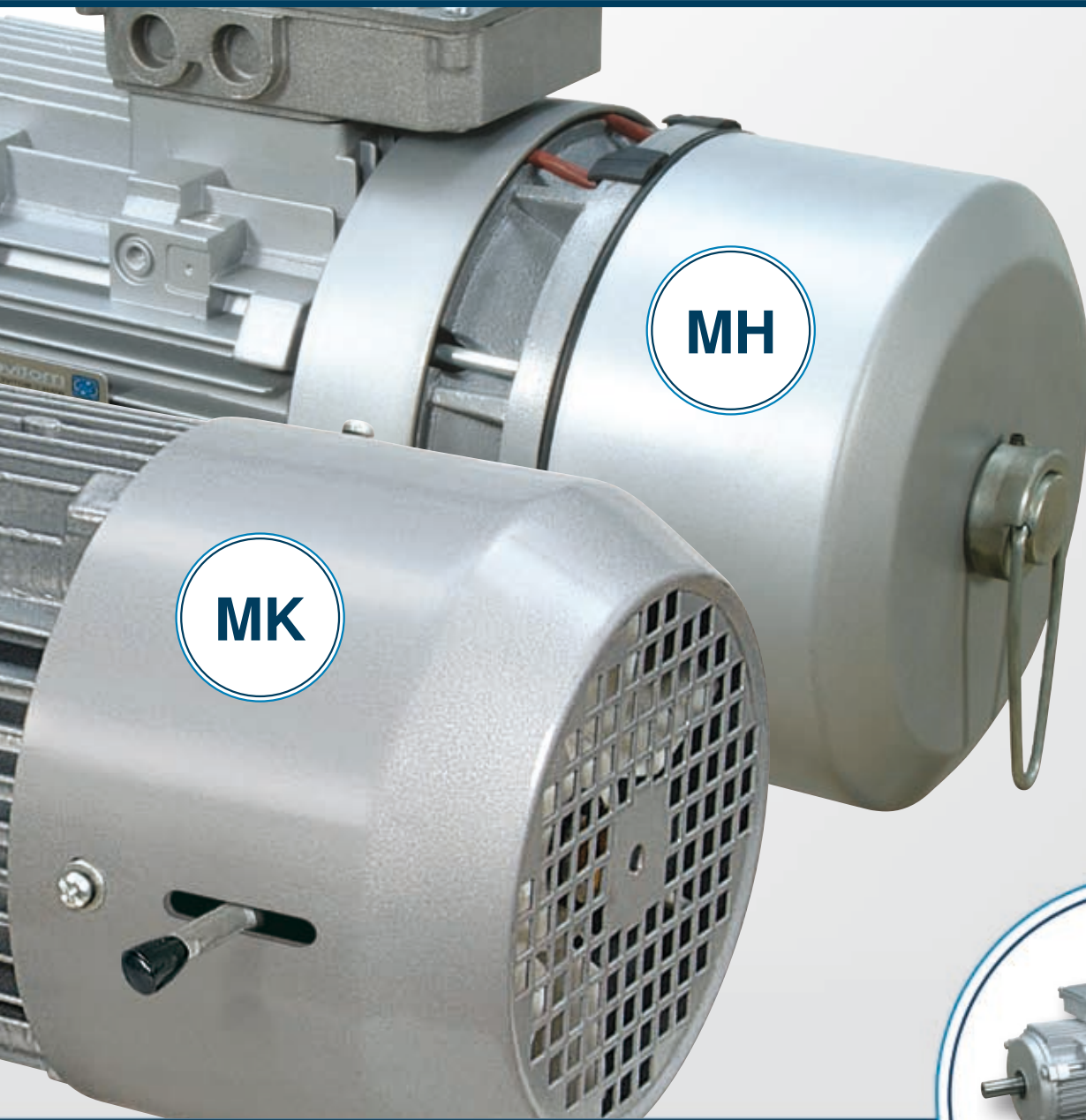

## THREE-PHASE INDUCTION SELF BRAKE MOTORS MK AND MH TYPES

These use spring-pressure brakes, firmly spliced onto a cast iron shield at the back of the motor.

Powered by direct current MK or alternating current MH, with negative action.

Motors are painted.

Manual release standard.

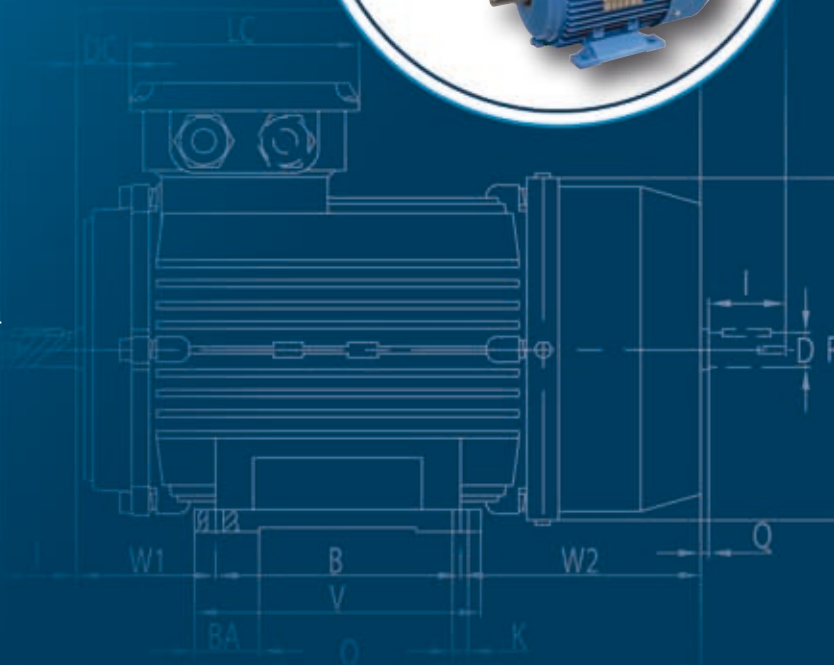

## 2 POLES 3000 rpm - Volt 230/400/50 Hz - Volt 280/480/60 Hz

Size	Power		Rpm	In (V380)	Is/In	Cn (Nm)	Cs/Cn	Cmax/Cn	Rend. % η	Cosφ %	Brake torque (Nm)	S	W	LwA (dB)	Weight kg	J Kgm <sup>2</sup>
	kW	HP														
63A	0,18	0,25	2720	0,50	5,5	0,61	2,2	2,3	65,0	0,80	4,0	0,15	25	58	7,8	0,00031
63B	0,25	0,37	2720	0,66	5,5	0,96	2,2	2,3	68,0	0,81	4,0	0,15	25	58	8,1	0,00060
71A	0,37	0,50	2740	0,94	6,1	1,26	2,2	2,3	70,0	0,81	4,0	0,15	25	61	9,0	0,00075
71B	0,55	0,75	2740	1,33	6,1	1,88	2,2	2,3	73,0	0,82	4,0	0,15	25	61	9,5	0,00090
80A	0,75	1,00	2840	1,73	6,1	2,54	2,2	2,3	75,1	0,83	7,5	0,20	50	64	12,7	0,00120
80B	1,10	1,50	2840	2,45	7,0	3,72	2,2	2,3	77,0	0,84	7,5	0,20	50	64	13,5	0,00140
90S	1,50	2,00	2840	3,26	7,0	5,14	2,2	2,3	79,0	0,84	15,0	0,25	60	69	16,3	0,00290
90L	2,20	3,00	2840	4,61	7,0	7,40	2,2	2,3	81,1	0,85	15,0	0,25	60	69	18,0	0,00550
100L	3,00	4,00	2860	6,01	7,5	9,95	2,2	2,3	82,8	0,87	30,0	0,30	80	73	27,0	0,01090
112M	4,00	5,50	2880	7,77	7,5	13,22	2,2	2,3	84,4	0,88	40,0	0,35	110	74	37,0	0,01260
132SA	5,50	7,50	2900	10,50	7,5	18,11	2,2	2,3	85,9	0,88	75,0	0,40	130	77	49,0	0,03770
132SB	7,50	10,00	2900	14,10	7,5	24,70	2,2	2,3	87,2	0,88	75,0	0,40	130	77	54,5	0,04990

## 4 POLES 1500 rpm - Volt 230/400/50 Hz - Volt 280/480/60 Hz

63A	0,12	0,18	1310	0,42	4,4	0,84	2,1	2,2	57,0	0,72	4,0	0,15	25	48	7,8	0,00050
63B	0,18	0,25	1310	0,95	4,4	1,26	2,1	2,2	60,0	0,73	4,0	0,15	25	48	8,1	0,00060
71A	0,25	0,37	1330	0,75	5,2	1,73	2,1	2,2	65,0	0,74	4,0	0,15	25	53	9,0	0,00080
71B	0,37	0,50	1330	1,06	5,2	2,56	2,1	2,2	67,0	0,75	4,0	0,15	25	53	9,5	0,00130
80A	0,55	0,75	1390	1,49	5,2	3,75	2,3	2,3	71,1	0,75	7,5	0,20	50	58	13,4	0,00180
80B	0,75	1,00	1390	1,95	6,0	5,11	2,3	2,3	73,1	0,76	7,5	0,20	50	58	14,8	0,00210
90S	1,10	1,50	1390	2,70	6,0	7,50	2,3	2,3	76,3	0,77	15,0	0,25	60	59	16,5	0,00230
90L	1,50	2,00	1390	3,49	6,0	10,23	2,3	2,3	78,6	0,79	15,0	0,25	60	59	18,3	0,00270
100LA	2,20	3,00	1410	4,83	7,0	14,80	2,3	2,3	81,2	0,81	30,0	0,30	80	61	26,8	0,00540
100LB	3,00	4,00	1410	6,39	7,0	20,18	2,3	2,3	82,7	0,82	30,0	0,30	80	61	29,5	0,00670
112M	4,00	5,50	1435	8,35	7,0	26,53	2,3	2,3	84,3	0,82	40,0	0,35	110	62	37,5	0,00950
132S	5,50	7,50	1440	11,10	7,0	36,48	2,3	2,3	85,8	0,83	75,0	0,40	130	69	51,5	0,02140
132M	7,50	10,00	1440	14,80	7,0	49,74	2,3	2,3	87,1	0,84	75,0	0,40	130	69	57,5	0,02960

## 6 POLES 1000 rpm - Volt 230/400/50 Hz - Volt 280/480/60 Hz

80A	0,37	0,50	885	1,23	4,7	3,93	1,9	2,0	62,0	0,70	7,5	0,20	50	51	12,9	0,00160
80B	0,55	0,75	885	1,69	4,7	5,84	1,9	2,1	65,0	0,72	7,5	0,20	50	51	14,4	0,00190
90S	0,75	1,00	910	2,18	5,5	7,87	2,0	2,1	69,0	0,72	15,0	0,25	60	54	16,6	0,00290
90L	1,10	1,50	910	3,02	5,5	11,54	2,0	2,1	72,1	0,73	15,0	0,25	60	54	18,2	0,00350
100L	1,50	2,00	920	3,79	5,5	15,24	2,0	2,1	76,1	0,75	30,0	0,30	80	58	29,0	0,00690
112M	2,20	3,00	935	5,28	6,5	22,35	2,1	2,1	79,2	0,76	40,0	0,35	110	62	36,2	0,01400
132S	3,00	4,00	960	7,03	6,5	29,84	2,1	2,1	81,1	0,76	75,0	0,40	130	66	50,2	0,02860
132MA	4,00	5,50	960	9,25	6,5	39,79	2,1	2,1	82,1	0,76	75,0	0,40	130	66	53,0	0,03570
132MB	5,50	7,50	960	12,30	6,5	54,71	2,1	2,1	84,1	0,77	75,0	0,40	150	66	57,2	0,04490

## 8 POLES 750 rpm - Volt 230/400/50 Hz - Volt 280/480/60 Hz

100LA	0,75	1,00	680	2,28	4,0	10,20	1,8	2,0	71,0	0,67	30,0	0,30	80	56	29,0	0,00950
100LB	1,10	1,50	680	3,15	5,0	15,00	1,8	2,0	73,0	0,69	30,0	0,30	80	56	31,1	0,01100
112M	1,50	2,00	690	4,18	5,0	20,50	1,8	2,0	75,0	0,69	40,0	0,35	110	59	38,2	0,02450
132S	2,20	3,00	705	5,73	6,0	29,60	1,8	2,0	78,0	0,71	75,0	0,40	130	61	50,3	0,03140
132M	3,00	4,00	705	7,51	6,0	40,40	1,8	2,0	79,0	0,73	75,0	0,40	130	61	55,0	0,03950

# Dimensions of three-phase brake motors - MK type standard torque

## B3 - B5 motors dimensions

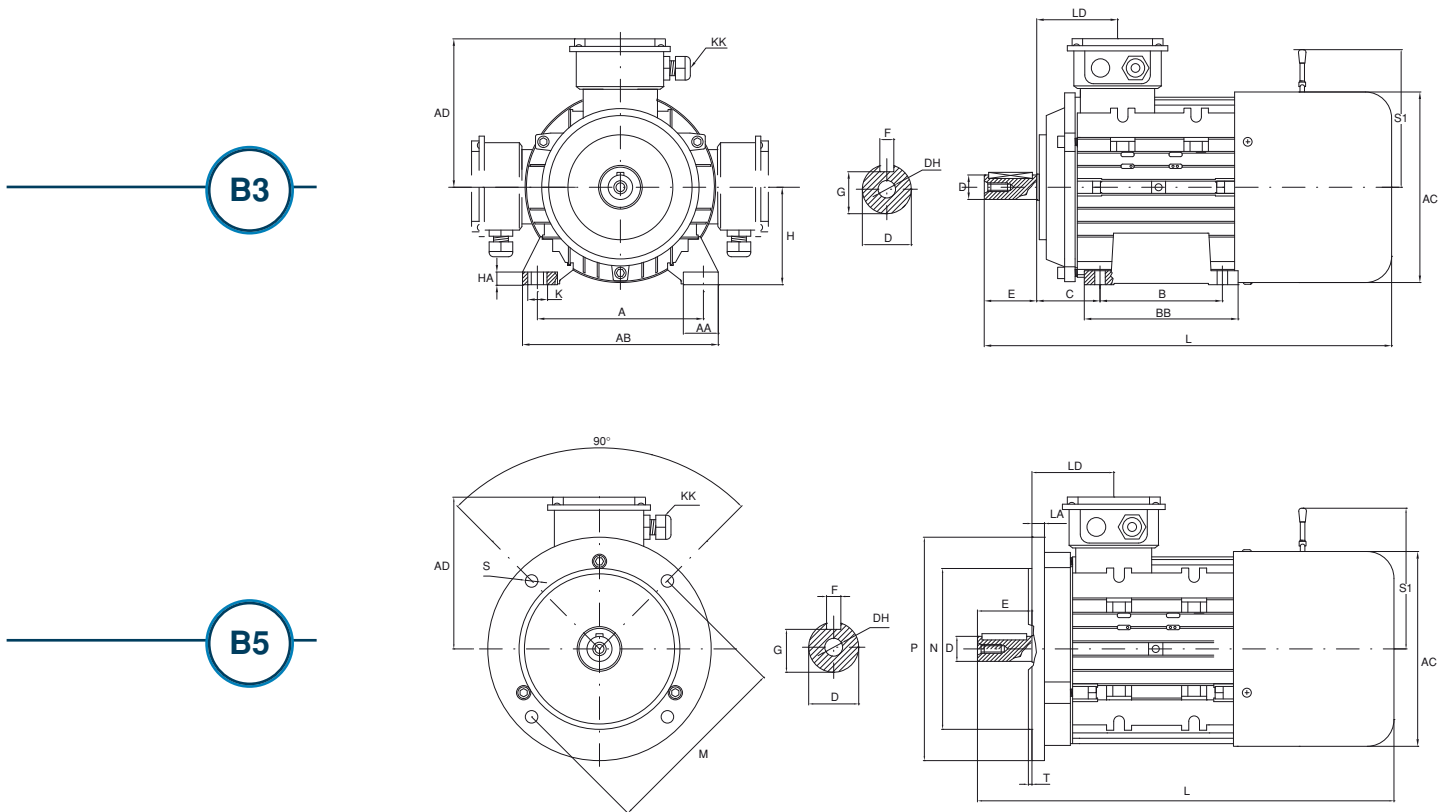

**B3 Dimensions**

Size	A	AA	B	BB	AB	K	HA	H	C	E	D	F	G	AC	AD	L	KK	DH	S1
63	100	24	80	100	135	7	7	63	40	23	11	4	8,5	130	111	240	1-M20 x 1,5	M4 x 12	98
71	112	26	90	110	150	7	8	71	45	30	14	5	11,0	145	118	270	1-M20 x 1,5	M5 x 12	98
80	125	35	100	125	165	10	9	80	50	40	19	6	15,5	175	134	375	1-M25 x 1,5	M6 x 16	111
90S	140	37	100	125	180	10	10	90	56	50	24	8	20,0	195	140	400	1-M25 x 1,5	M8 x 19	129
90L	140	37	125	150	180	10	10	90	56	50	24	8	20,0	195	140	426	1-M25 x 1,5	M8 x 19	129
100L	160	40	140	172	205	12	11	100	63	60	28	8	24,0	215	160	465	2-M32 x 1,5	M10 x 22	139
112M	190	41	140	181	230	12	12	112	70	60	28	8	24,0	240	178	495	2-M32 x 1,5	M10 x 28	161
132S	216	51	140	186	270	12	15	132	89	80	38	10	33,0	275	206	570	2-M32 x 1,5	M12 x 28	186
132M	216	51	178	224	270	12	15	132	89	80	38	10	33,0	275	206	610	2-M32 x 1,5	M12 x 28	186
160M	254	65	210	304	320	15	22	160	108	110	42	12	37,0	330	255	715	2-M40 x 1,5	M16 x 36	242
160L	254	65	254	304	320	15	22	160	108	110	42	12	37,0	330	255	760	2-M40 x 1,5	M16 x 36	242

**B5 Dimensions**

Size	D	E	F	G	M	N	P	S	T	AC	AD	L	KK	DH	S1
63	11	23	4	8,5	115	95	140	10	3,0	130	111	240	1-M20 x 1,5	M4 x 12	98
71	14	30	5	11,0	130	110	160	10	3,5	145	118	270	1-M20 x 1,5	M5 x 12	98
80	19	40	6	15,5	165	130	200	12	3,5	175	134	375	1-M25 x 1,5	M6 x 16	111
90S	24	50	8	20,0	165	130	200	12	3,5	195	140	400	1-M25 x 1,5	M8 x 19	129
90L	24	50	8	20,0	165	130	200	12	3,5	195	140	426	1-M25 x 1,5	M8 x 19	129
100L	28	60	8	24,0	215	180	250	15	4,0	215	160	465	2-M32 x 1,5	M10 x 22	139
112M	28	60	8	24,0	215	230	250	15	4,0	240	178	495	2-M32 x 1,5	M10 x 28	161
132S	38	80	10	33,0	265	230	300	15	4,0	275	206	570	2-M32 x 1,5	M12 x 28	186
132M	38	80	10	33,0	265	250	300	15	4,0	275	206	610	2-M32 x 1,5	M12 x 28	186
160M	42	110	12	37,0	300	250	350	19	5,0	330	255	715	2-M40 x 1,5	M16 x 36	242
160L	42	110	12	37,0	300	250	350	19	5,0	330	255	760	2-M40 x 1,5	M16 x 36	242

## B14 motor dimensions

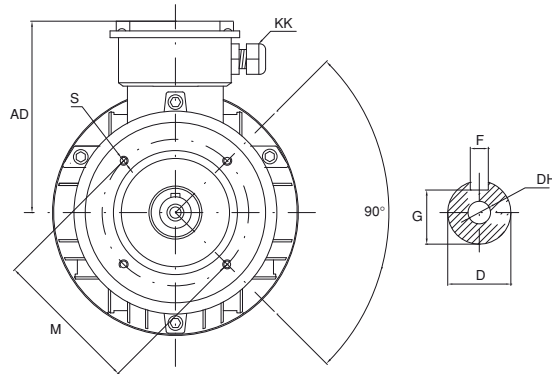

**B14**

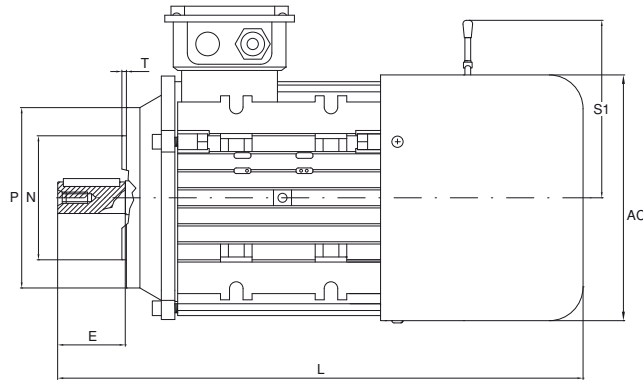

Size	Dimensions														
	D	E	F	G	M	N	P	S	T	AC	AD	L	KK	DH	S1
<b>63</b>	11	23	4	8,5	75	60	90	M5	2,5	130	111	240	1-M20 x 1,5	M4 x 12	98
<b>71</b>	14	30	5	11,0	85	70	105	M6	2,5	145	118	270	1-M20 x 1,5	M5 x 12	98
<b>80</b>	19	40	6	15,5	100	80	120	M6	3,0	175	134	375	1-M25 x 1,5	M6 x 16	111
<b>90S</b>	24	50	8	20,0	115	95	140	M8	3,0	195	140	400	1-M25 x 1,5	M8 x 19	129
<b>90L</b>	24	50	8	20,0	115	95	140	M8	3,0	195	140	426	1-M25 x 1,5	M8 x 19	129
<b>100L</b>	28	60	8	24,0	130	110	160	M8	3,5	215	160	465	2-M32 x 1,5	M10 x 22	139
<b>112M</b>	28	60	8	24,0	130	110	160	M8	3,5	240	178	495	2-M32 x 1,5	M10 x 28	161
<b>132S</b>	38	80	10	33,0	165	130	200	M10	3,5	275	206	570	2-M32 x 1,5	M12 x 28	186
<b>132M</b>	38	80	10	33,0	165	130	200	M10	3,5	275	206	610	2-M32 x 1,5	M12 x 28	186
<b>160M</b>	42	110	12	37,0	215	180	250	M12	4,0	330	255	715	2-M40 x 1,5	M16 x 36	242
<b>160L</b>	42	110	12	37,0	215	180	250	M12	4,0	330	255	760	2-M40 x 1,5	M16 x 36	242

**2 POLES** 3000 rpm - Volt 230/400/50 Hz - Volt 280/480/60 Hz

Size	Power		Rpm	In (V400)	Is/In	Cn (Nm)	Cs/Cn	Cmax/Cn	Rend. % $\eta$	Cos $\phi$ %	Brake torque (Nm)	S	LwA (dB)	Weight kg	J Kgm <sup>2</sup>
	kW	HP													
71A	0,37	0,50	2740	0,94	6,1	1,26	2,2	2,3	70,0	0,81	14	0,15	61	9,3	0,00075
71B	0,55	0,75	2740	1,33	6,1	1,88	2,2	2,3	73,0	0,82	14	0,15	61	10,5	0,00090
80A	0,75	1,00	2840	1,73	6,1	2,54	2,2	2,3	75,1	0,83	18	0,20	64	14,5	0,00120
80B	1,10	1,50	2840	2,45	7,0	3,72	2,2	2,3	77,0	0,84	18	0,20	64	15,5	0,00140
90S	1,50	2,00	2840	3,26	7,0	5,14	2,2	2,3	79,0	0,84	38	0,25	69	20,0	0,00290
90L	2,20	3,00	2840	4,61	7,0	7,40	2,2	2,3	81,1	0,85	38	0,25	69	22,5	0,00550
100L	3,00	4,00	2860	6,01	7,5	9,95	2,2	2,3	82,8	0,87	50	0,30	73	30,5	0,01090

**4 POLES** 1500 rpm - Volt 230/400/50 Hz - Volt 280/480/60 Hz

71A	0,25	0,37	1330	0,75	5,2	1,73	2,1	2,2	65,0	0,74	14	0,15	53	9,3	0,00060
71B	0,37	0,50	1330	1,06	5,2	2,56	2,1	2,2	67,0	0,75	14	0,15	53	10,5	0,00075
80A	0,55	0,75	1390	1,49	5,2	3,75	2,3	2,3	71,1	0,75	18	0,20	58	14,0	0,00090
80B	0,75	1,00	1390	1,95	6,0	5,11	2,3	2,3	73,1	0,76	18	0,20	58	15,0	0,00120
90S	1,10	1,50	1390	2,70	6,0	7,50	2,3	2,3	76,3	0,77	38	0,25	59	20,0	0,00140
90L	1,50	2,00	1390	3,49	6,0	10,23	2,3	2,3	78,6	0,79	38	0,25	59	22,5	0,00290
100LA	2,20	3,00	1410	4,83	7,0	14,80	2,3	2,3	81,2	0,81	50	0,30	61	30,2	0,00550
100LB	3,00	4,00	1410	6,39	7,0	20,18	2,3	2,3	82,7	0,82	50	0,30	61	33,0	0,00580

**6 POLES** 1000 rpm - Volt 230/400/50 Hz - Volt 280/480/60 Hz

71A	0,18	0,25	850	0,70	4,0	1,91	1,9	2,0	56,0	0,66	14	0,15	49	10,5	0,00040
71B	0,25	0,37	850	0,90	4,0	2,65	1,9	2,0	59,0	0,68	14	0,15	49	10,5	0,00055
80A	0,37	0,50	885	1,23	4,7	3,93	1,9	2,0	62,0	0,70	18	0,20	51	14,5	0,00060
80B	0,55	0,75	885	1,69	4,7	5,84	1,9	2,1	65,0	0,72	18	0,20	51	15,5	0,00075
90S	0,75	1,00	910	2,18	5,5	7,87	2,0	2,1	69,0	0,72	38	0,25	54	19,5	0,00090
90L	1,10	1,50	910	3,02	5,5	11,54	2,0	2,1	72,1	0,73	38	0,25	54	22,0	0,00120
100L	1,50	2,00	920	3,79	5,5	15,24	2,0	2,1	76,1	0,75	50	0,30	58	30,5	0,00140

**8 POLES** 750 rpm - Volt 230/400/50 Hz - Volt 280/480/60 Hz

80A	0,18	0,25	645	0,84	3,3	2,5	1,8	1,9	51,0	0,61	18	0,20	48	14,5	0,00040
80B	0,25	0,37	645	1,10	3,3	3,5	1,8	1,9	54,0	0,61	18	0,20	48	15,5	0,00055
90S	0,37	0,50	670	1,41	4,0	5,1	1,8	1,9	62,0	0,61	38	0,25	53	19,5	0,00060
90L	0,55	0,75	670	2,07	4,0	7,6	1,8	2,0	63,0	0,61	38	0,25	53	22,0	0,00075
100LA	0,75	1,00	680	2,28	4,0	10,2	1,8	2,0	71,0	0,67	50	0,30	56	30,5	0,00090

## B3 - B5 - B14 motors dimensions

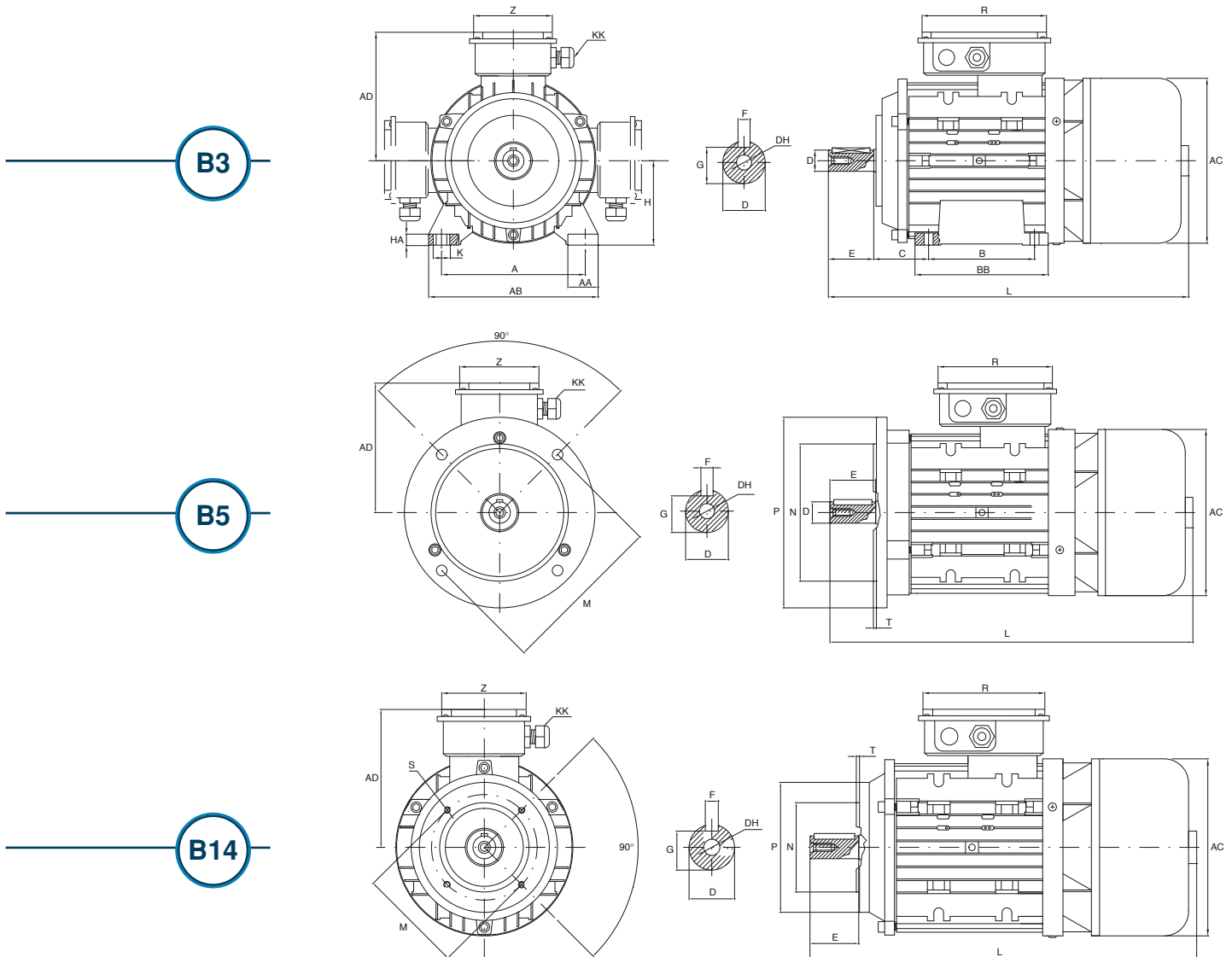

**Dimensions B3**

Size	A	AA	B	BB	AB	K	HA	H	C	E	D	F	G	R	Z	AC	AD	L	KK	DH
71	112	26	90	110	150	7	8,5	71	45	30	14	5	11,0	122	75,0	140	118	342	1-M20 x 1,5	M5 x 12
80	125	35	100	125	165	10	8,5	80	50	40	19	6	15,5	122	75,0	159	134	370	1-M25 x 1,5	M6 x 16
90S	140	37	100	125	180	10	10,5	90	56	50	24	8	20,0	130	98,5	179	140	410	1-M25 x 1,5	M8 x 19
90L	140	37	125	150	180	10	10,5	90	56	50	24	8	20,0	130	98,5	179	140	435	1-M25 x 1,5	M8 x 19
100L	160	40	140	172	205	12	11,5	100	63	60	28	8	24,0	140	100,0	199	160	485	2-M32 x 1,5	M10 x 22

**Dimensions B5**

Size	D	E	F	G	M	N	P	R	T	Z	AC	AD	L	KK	DH
71	14	30	5	11,0	130	110	160	122	3,5	75,0	140	118	342	1-M20 x 1,5	M5 x 12
80	19	40	6	15,5	165	130	200	122	3,5	75,0	159	134	370	1-M25 x 1,5	M6 x 16
90S	24	50	8	20,0	165	130	200	130	3,5	98,5	179	140	410	1-M25 x 1,5	M8 x 19
90L	24	50	8	20,0	165	130	200	130	3,5	98,5	179	140	435	1-M25 x 1,5	M8 x 19
100L	28	60	8	24,0	215	180	250	140	4,0	100,0	199	160	485	2-M32 x 1,5	M10 x 22

**Dimensions B14**

Size	D	E	F	G	M	N	P	R	S	T	Z	AC	AD	L	KK	DH
71	14	30	5	11,0	85	70	105	122	M6	2,5	75,0	140	118	342	1-M20 x 1,5	M5 x 12
80	19	40	6	15,5	100	80	120	122	M6	3,0	75,0	159	134	370	1-M25 x 1,5	M6 x 16
90S	24	50	8	20,0	115	95	140	130	M8	3,0	98,5	179	140	410	1-M25 x 1,5	M8 x 19
90L	24	50	8	20,0	115	95	140	130	M8	3,0	98,5	179	140	435	1-M25 x 1,5	M8 x 19
100L	28	60	8	24,0	130	110	160	140	M8	3,5	100,0	199	160	485	2-M32 x 1,5	M10 x 22



## Installation, use and maintenance technical manual for CE-marked electric motors

### NERI MOTORI srl - CE MARK - Electric motor constructor

Via A. Fleming n. 6/8 - S - Giovanni in Persiceto - Bologna - Italy.  
Tel. +39 051 6870911 - Fax. +39 051 825858 - Mail: info@nerimotori.com

### Installation use and maintenance technical manual for CE marked electric motors

Neri Motori srl declares that the electrical material quoted in this technical manual complies with the following EU Directives:

- MD EC 98/37 (Machine Directive) - Annex IIB;
- LV EC/2006/95 (Low voltage);
- EMC EEC/89/336 (Electromagnetic Compatibility) and subsequent amendments. The adopted test methods comply with EN-55014 Standards (1994) as far as EMC is concerned: - Peak test run in the 150kHz-30Mhz band - Irradiated test run in the 30 Mhz-1Ghz band.

**and MUST NOT RUN BEFORE ASSEMBLED in a CE MACHINERY.**

### DANGER

0) Before operating the electrical material subject-matter of this installation use and maintenance technical manual provided with the electrical motors marked with CE rating plate (from this point on the term electric motor will be used in lieu of L.V. electrical material) carefully read the instructions stated.

The instructions are to be fully and duly complied with before skilled personnel and qualified technicians start up the electric motor.

Keep in mind that this manual does not exempt anyone from applying all those technical standards envisaged in the specific sector of electric motors or those general standards associated with the safety of persons animals or property EN 60204-1 set forth by the EEC.

### ELECTRIC MOTOR INSTALLATION

1) Skilled, trained personnel are in charge of performing the installation and maintenance operations concerning the use of the electric motor EN60204-1.

2) Before starting up the electric motor check its overall condition, the shaft, the condition of the fan cover, the wear of the mechanical parts.

Also check that the motor shaft turns freely, that the gasket and cable in let are right mounted.

Check that all the electrical terminals are wired in the terminal strip, that the values reported on the motor's rating plate match those of the mains that will power it. If such values not match in rating or ENVIRONMENTAL CONDITION ARE DIFFERENT do not start the electric motor.

3) Fix the motor into its seat using suitable fastening equipment, is AVOID using the electric motor's eyebolt if it's connected to other machine parts.

4) To handle the motor, if it is very heavy (>30kg) or if it cannot be perfectly handled because it is not placed on safe supports, use machine tools or the like to prevent physical injury conforming to EEC directives.

5) Do not start the electric motor if the key is fixed on the motor shaft because it might be expelled owing to centrifugal force.

This fact could be extremely risky as per EN 60204-1.

6) Make sure that the assembly of the electric motors permits a correct air intake as well as the circulation and discharging of the coolant on its frame. Also make sure that even when the motor is running its frame is devoid of encrustation or dust that would worsen the heat exchange with the air coolant which would entail faulty over heating risk.

7) Before performing any type of maintenance operations to the electric motor or its whereabouts, visually make sure that it has been disconnected from the mains power supply, make sure that it is impossible for the motor to restart unexpectedly and also make sure that the other earth wires cinematically connected to the motor shaft cannot drive its motion as per EN 60204-1.

8) It is prohibited to use the motor in environments the conditions of which differ from the IP ratings specified on the plate as per EN 60054-5.

9) Connect the motor's frame to earth using the appropriate equipotential terminal identified by the symbol as per EN 60204-1.

10) If the electric motor is to be stored, the temperature of the room should be from -5°C to +40°C. In any case after it has been stored for 12 months check the insulation resistance that should be approximately 1MΩ with continuous test voltage of 500V for Vn < 500V.

Should you notice any differences in the value this might be due to the presence of humidity in the windings to be dried, then repeat the test .

11) Make sure that the mechanical protections of the motor's moving parts or parts connected to it, for instance the pulley belt units, are sufficient as far as safety for personnel, animals or property are concerned, as per EN 60204-1.

12) Check that the alignment between motor shaft and rotating parts keyed to the motor is correct or that they are statically and dynamically balanced ISO 1940-1, for preventing undesired moments as per EN 60204-1.

13) The shaft of the electric motor has been designed and finished conforming to IEC 72-1 and is to be operated with out any shear stress. Shield flange frames and mechanical parts manufactured by us conform to IEC 72-1 Standard.

14) Make sure that the electric motor and user units is not a source of noise with A - weighted equivalent continuous acoustic pressure levels LpA > 80 dBA as set forth by EEC directives.

Otherwise the unit must be silenced or workers must protect themselves with individual acoustic protective gear.

15) Make sure that the hot parts of the electric motor must be that attain temperatures >80°C are adequately protected against touching by personnel animals or property as per EN 60204-1.

16) All risk situations must be adequately indicate with graphics sign such as for instance voltage excessive noise or temperature.

### ELECTROMECHANICAL SAFETIES OF THE ELECTRIC MOTOR (EN 60204-1)

17) Envisage a safety device against overloads for powers supplied > 500W in thermal service S1. This can be achieved with a thermal relay and a contactor. It is advisable to fit a thermal safety device at the motor windings by means of a thermistor or a bimetallic device in scarcely ventilated places such as inside the guards. The tripping temperature depends on the insulation class as per EN 60204-1.

18) If required by particular operating conditions of the electric motor in synchronism with other machine envisage the application of a minimum voltage relay and contactor as per EN 60204-1.

19) Variable speed applications are not allowed unless expressly agreed upon at the time the order is being prepared with the manufacturer and in any case that differ from the rated rotating speed as per EN 60204-1.

20) If the speed range is agreed upon with the manufacturer and this fact might trigger risky situation envisage a safety device against electric motors over speed as per EN 60204-1.

21) A safety device must be envisaged against electric motor over currents by means of magnetic relay and contactor or fuses as per EN 60204-1.

22) Carry out the sizing of the electric motor power supply cables and the admissible voltage % drop conforming to EN 60204-1.

23) Cables are to be thermally sized considering the through power ( $I^2 \cdot t = K^2 \cdot S^2$ ) as per EN 60204-1.

24) When Ig [A] fault current is know at the expected fault point K and S calculate the maximum tripping time DeltaT of magnetic circuit breakers.

25) Personnel animals and property must be protected against indirect part contacts that as a rule are not subjected to electric potential but that might be subjected to it because of malfunction.

Therefore fit a differential relay and contactor with Id<30mA as per EN 60204-1.

26) If the turning direction of the motor shaft has been set to one direction only such direction must be clearly indicated with arrow as EN60204-1.

27) In the events the motor brakes electrically by means of the inversion of two power supply wires the motor must no be capable of restarting .

28) Rearming a safety device is strictly prohibited. This may be done only and exclusively by the manual intervention of personnel who are skilled in rearming operations as per EN 60204-1.

29) The components of the motor are in weight approximately 5% inorganic - iron 55% - copper 30% - aluminium 10% - and are to be disposed of conforming to EEC directives.

Date 04/04/2008. San Giovanni in Persiceto - Bologna - ITALY.

NERI MOTORI

## General conditions of sale

### Offers

Offers are valid for 30 days unless otherwise specified in the offer itself.

### Orders

Orders are only valid and binding if made in writing or signed on our agents' order forms.

If the purchaser refuses to take delivery, by signing he has undertaken to pay the seller a sum of 25% of the total amount of the order for standard products. For non standard products, 100% of the amount must be paid.

### Deliveries

Delivery dates are always guideline and may be postponed in cases of force majeure. In this case the seller will be entitled to terminate the contract, if compatible with the purchaser's requirements.

### Shipments

Goods are shipped ex-works, and freight expenses are always for the purchaser's account.

### Guarantee

The seller undertakes to repair or replace free of charge all parts found defected for causes of material or processing, provided the complaints are made within no more than 12 months after consignment of the delivery note accompanying the material.

The disputed goods will always be repaired at the seller's factory and must be delivered freight prepaid.

The seller also declines all responsibility for damage of any kind which occurs because of product breakdowns, even if it has designed their application.

### Prices

Prices are calculated with references to the costs at the moment of order; any variations in these costs will entitle the seller to modify its prices.

The prices stated in the confirmation of order are always net of packaging, freight, VAT and all other indirect costs.

### Payments

Payments must be made by the agreed dates and are only considered valid if they are made to the seller's head office.

Payments may not be suspended for any reason.

In case of breach of payment terms, the seller reserves the right to suspend the supply of all further goods and to charge all resulting damages to the purchaser.

In case of controversies, the Bologna Law Court will have jurisdiction.

### Reservation of right to modification

This publication yearly replaces every previous edition or revision.

We reserve the right to make modifications without notice.

The data indicated in this catalogue are simply general information.

